

DIRECTED®

Directed Passive Keyless Entry (PKE) Model 2102T Installation Guide

This product is intended for installation by a professional installer only! Attempts to install this product by a person other than a trained professional may result in severe damage to a vehicle's electrical system and components.

© 2012 Directed, Vista, CA
N2102T 2012-07

Contents

Antenna Mounting and Installation Points	5
Vehicle Category Installation Specification	5
Installation Type Selection	6
Installation diagram.....	7
Wiring connections	19
D2D port (H2), 4-pin black connector	19
Feature Programming	20
Entering feature programming routine	20
Changing feature options	20
Accessing another feature.....	20
Exiting feature programming	20
Features and Options List.....	21
SmartLock feature.....	22
Remote pairing	23
Pairing the FOB to the PKE module:.....	23
Pairing the PKE system to the remote starter module:	23
Factory reset.....	23
Diagnostics	23

Warning! safety first



The following safety warnings must be observed at all times:

Due to the complexity of this system, installation of this product must only be performed by an authorized Directed dealer. When properly installed, this system can lock and unlock your doors and also arm and disarm your Directed security system when the key fob is in and out of range.

The following precautions are the sole responsibility of the user; however, authorized Directed dealers should: Never use a test light or logic probe when installing this unit. Always use a multimeter.

Antenna Mounting and Installation Points

In order to maximize range, the following antenna mounting options should be discussed with the customer to better suit their needs.

Warning

- Do not directly mount the antenna on any metallic surface, this may significantly decrease the range.
- To insure consistent operation, secure the antenna and make sure they will not move or dangle.
- Antennas are fragile, they can break easily. Make sure they are mounted on a solid (non flexible) part.

Recommended Antenna Mounting Locations

The recommended antenna mounting locations are for reference only. It is still required that you perform the actual range test when installing the antenna to ensure that the range is satisfactory. You may require to relocate the antennas to different areas around the recommended locations until maximum range is achieved.

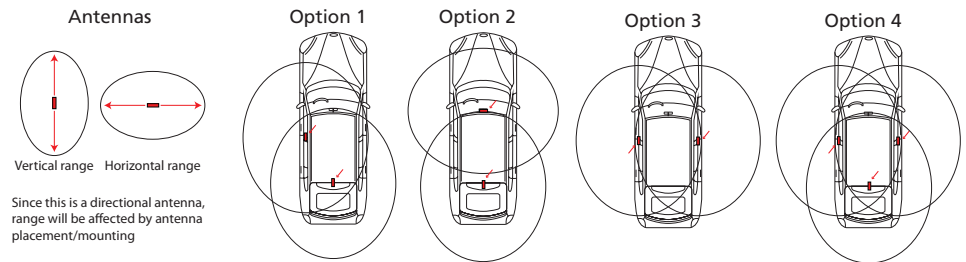

Note: An optional 12-foot antenna (part# SANT-PKE12) can be installed to increase the active zone coverage. When a third antenna is installed, feature 4, option 2 must be enable through the "Features and Options List" section on page 21.

Vehicle Category Installation Specification

Sub Compact, Compact & Sedan:

For optimal performance, install the 18-foot antenna in the headliner or below the rear deck.

Note: Installation in the trunk will greatly affect and reduce range and overall system performance.

Minivan & SUV:

To maximize range in the rear of the vehicle, install the 18-foot antenna in the headliner.

Pickup (with cab) & Cargo:

To maximize range in the rear of the vehicle, install the 18-foot antenna in the bumper, behind the license plate.

Pickup (without cab):

Suggested Installation: Option 3. Antennas should be mounted on the driver and passenger side since the tailgate does not require to be controlled.

Convertible:

Install 8-foot antenna in windshield pillar on driver side and the 18-foot antenna behind the rear seats.

Note: On vehicle with fiberglass bodies or convertibles, the range will be significantly increased.

Installation Type Selection

Choosing the right installation type according to the device you install.

Corresponding installation type according to what device you are installing	Page
Type 1 - PKE Standalone	page 7
Type 2a - PKE + Xpresskit Bypass + AutoStart or AstroStart or Viper/Python/Clifford Directed Remote Starter (with 4-pin antenna connector)	page 8
Type 2b - PKE + Xpresskit Bypass + Viper/Python/Clifford Directed Remote Starter (with 6-pin antenna connector)	page 9
Type 3a - PKE + Xpresskit Bypass + DIRECTED SmartStart + Autostart or Astrostart Directed Remote Starter (with 4-pin antenna connector)	page 10
Type 3b - PKE + Xpresskit Bypass + DIRECTED SmartStart + Viper/Python/Clifford Directed Remote Starter (with 6-pin antenna connector)	page 11
Type 3c - PKE + Xpresskit Bypass + DIRECTED SmartStart + Viper/Python/Clifford Directed Remote Starter (with 4-pin antenna connector)	page 12
Type 4 - PKE + 4x10/5x10	page 13
Type 5 - PKE + Xpresskit Bypass	page 14
Type 6 - PKE + DIRECTED SmartStart + 4x10/5x10	page 15
Type 7 - PKE + Xpresskit Bypass - Remote Start Ready (RSR) + DIRECTED SmartStart	page 16
Type 8 - PKE + Xpresskit Bypass - Range Extender (RXT) + XL202	page 17
Type 9 - PKE + AutoStart or AstroStart or Viper/Python/Clifford Directed Remote Starter (with 4pin antenna connector)	page 18

Installation diagram

Type 1 - PKE Standalone

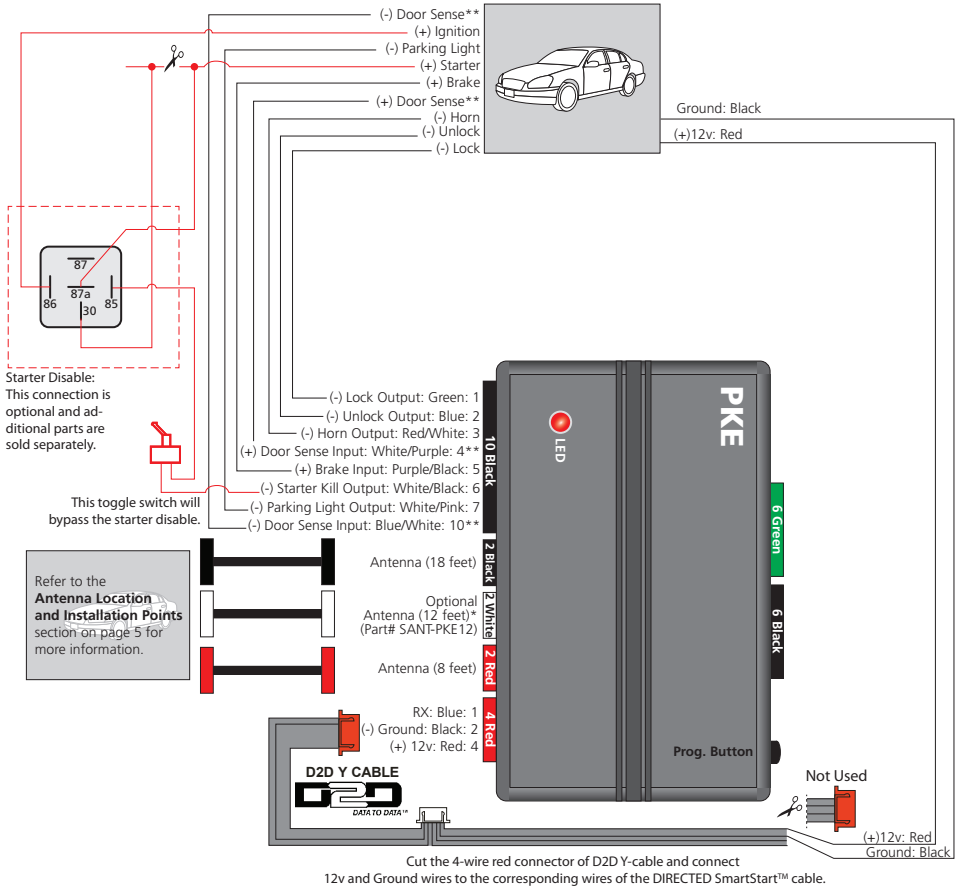

*Sold separately.

**Door sense: The polarity of the door sense in the vehicle will determine which wire to connect from the PKE to the DIRECTED Remote Starter.

Type 2a - PKE + Xpresskit Bypass + AutoStart or AstroStart or Viper/Python/Clifford Directed Remote Starter (with 4-pin antenna connector)

Note: 8210 Antenna Universal Adapter is required and sold separately.

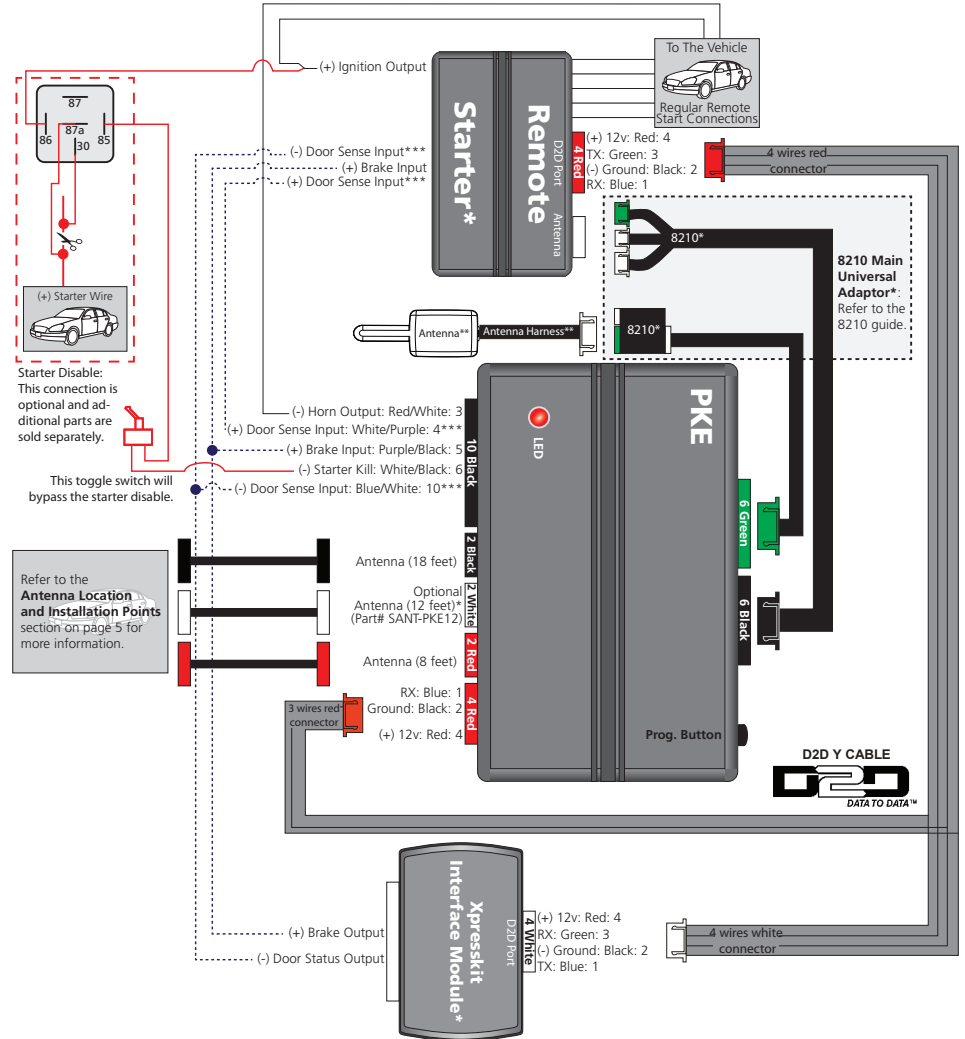

..... These wires are **not** required in D2D mode.

*Sold separately.

**Antenna & Antenna harness are sold with your Remote Starter kit.

*** Door sense: The polarity of the door sense in the vehicle will determine which wire to connect from the PKE to the DIRECTED Remote Starter.

Type 2b - PKE + Xpresskit Bypass + Viper/Python/Clifford Directed Remote Starter (with 6-pin antenna connector)

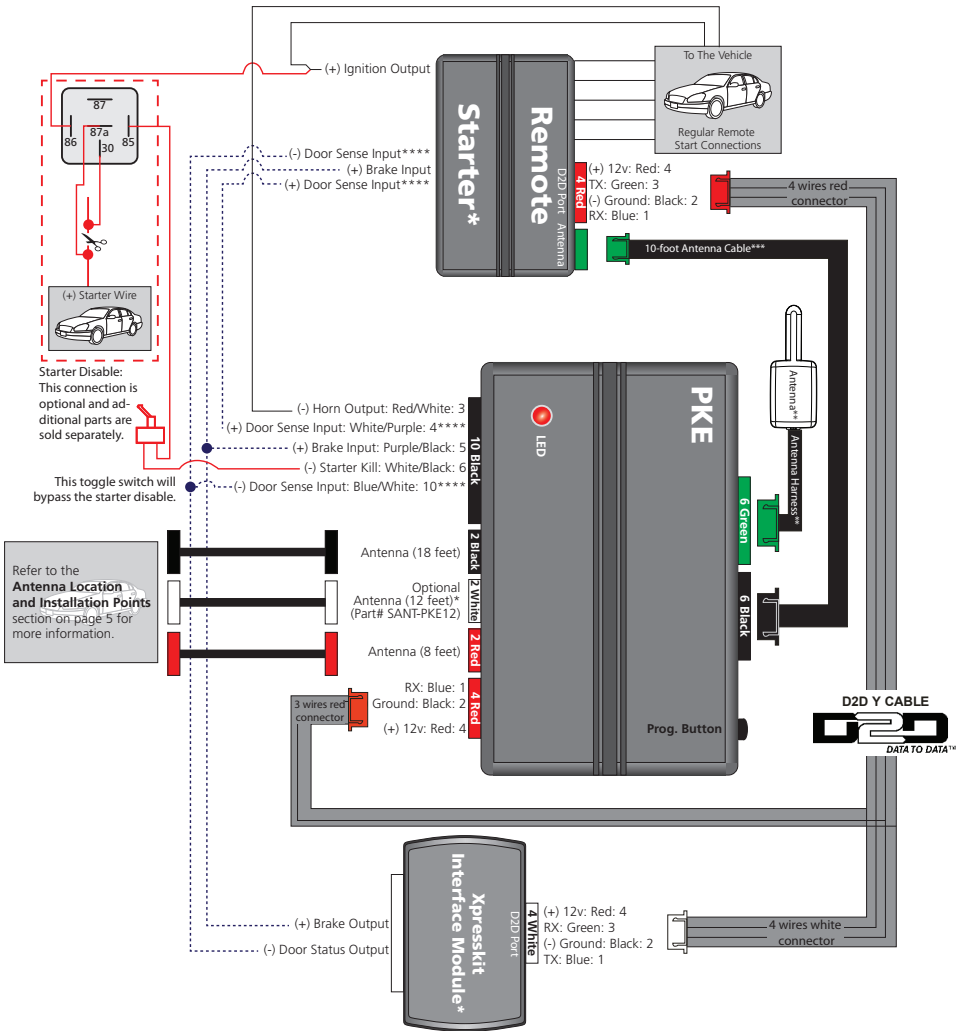

Type 3a - PKE + Xpresskit Bypass + DIRECTED SmartStart + Autostart or Astrostart or Astrostart Directed Remote Starter (with 4-pin antenna connector)

Note: 8210 Antenna Universal Adaptor is required and sold separately.

The remote starter model will determine which connector to use. Refer to the DIRECTED SmartStart install guide for proper connection.

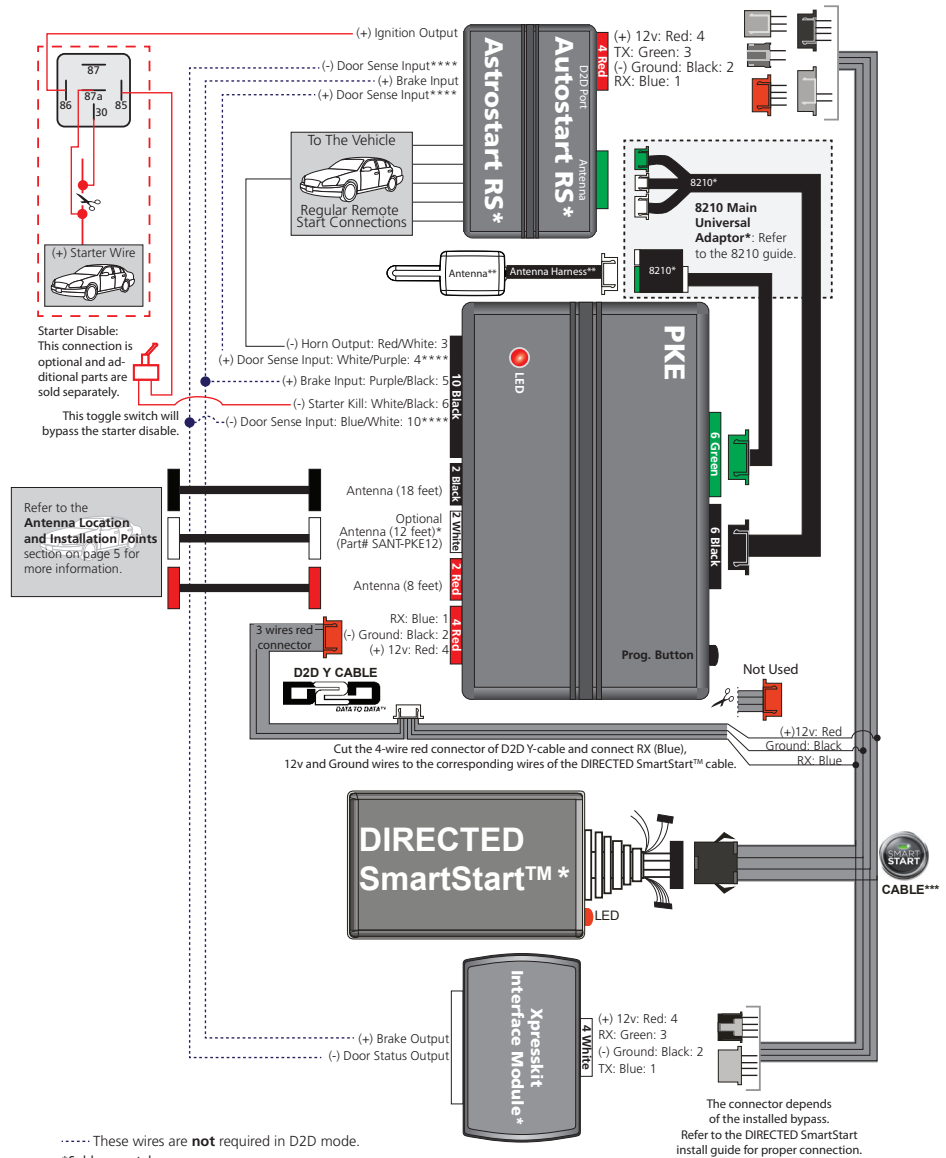

..... These wires are **not** required in D2D mode.

*Sold separately.

**Antenna & Antenna harness are sold with your Remote Starter kit.

***DIRECTED SmartStart™ cable is sold with your DIRECTED SmartStart™ system.

**** Door sense: The polarity of the door sense in the vehicle will determine which wire to connect from the PKE to the DIRECTED Remote Starter.

Type 3b - PKE + Xpresskit Bypass + DIRECTED SmartStart + Viper/Python/Clifford Directed Remote Starter (with 6-pin antenna connector)

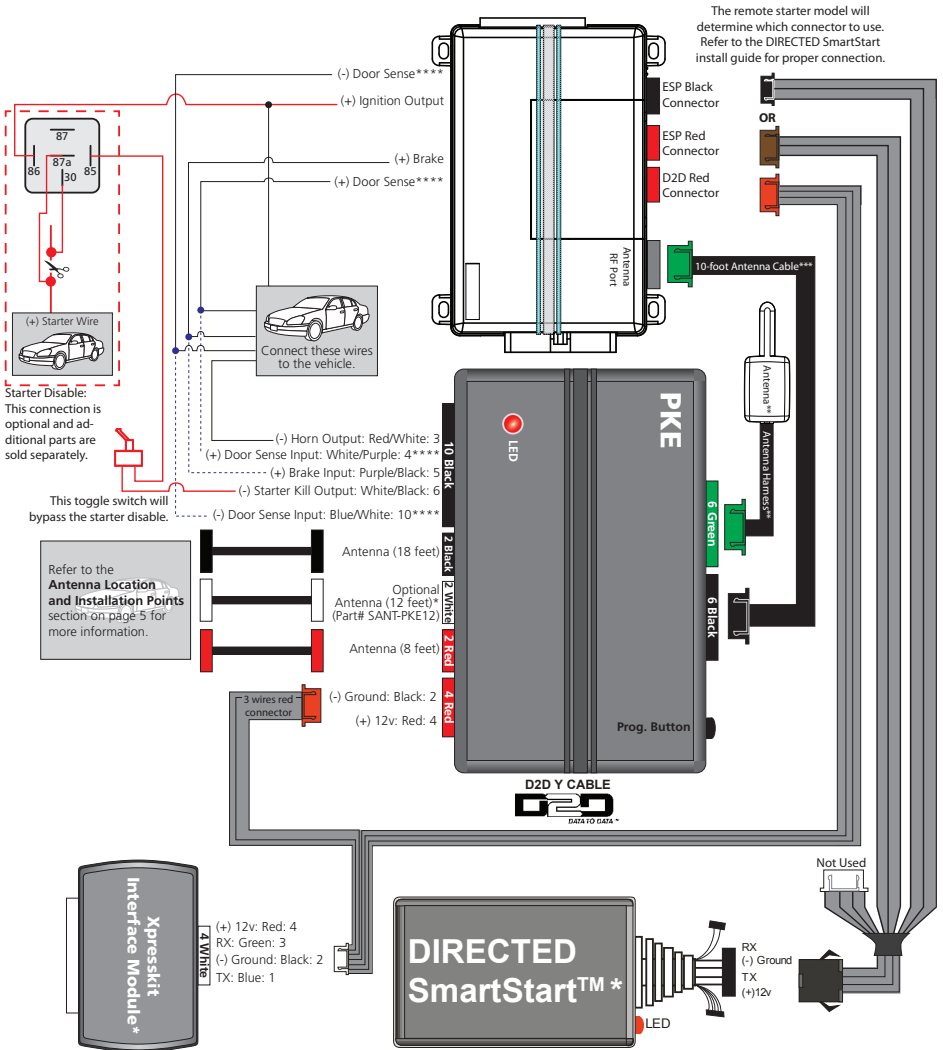

*Sold separately.

**Antenna, Antenna harness & DIRECTED SmartStart™ cable are sold with your Remote Starter kit.

***10-foot Antenna Cable is included in the PKE kit.

**** Door sense: The polarity of the door sense in the vehicle will determine which wire to connect from the PKE to the DIRECTED Remote Starter.

Type 3c - PKE + Xpresskit Bypass + DIRECTED SmartStart + Viper/Python/Clifford Directed Remote Starter (with 4-pin antenna connector)

Note: 8210 Antenna Universal Adapter is required and sold separately.

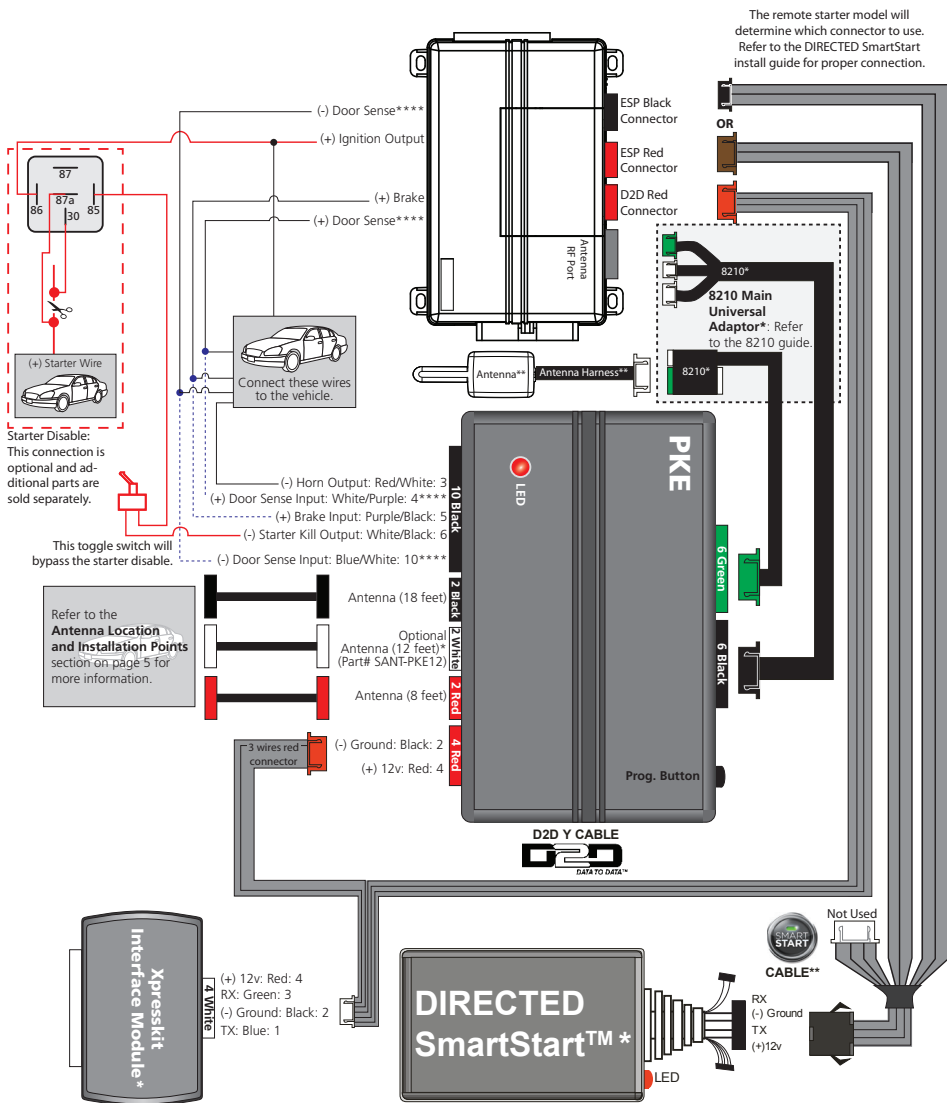

*Sold separately.

**Antenna, Antenna harness & DIRECTED SmartStart™ cable are sold with your Remote Starter kit.

***10-foot Antenna Cable is included in the PKE kit.

**** Door sense: The polarity of the door sense in the vehicle will determine which wire to connect from the PKE to the DIRECTED Remote Starter.

Type 4 - PKE + 4x10/5x10

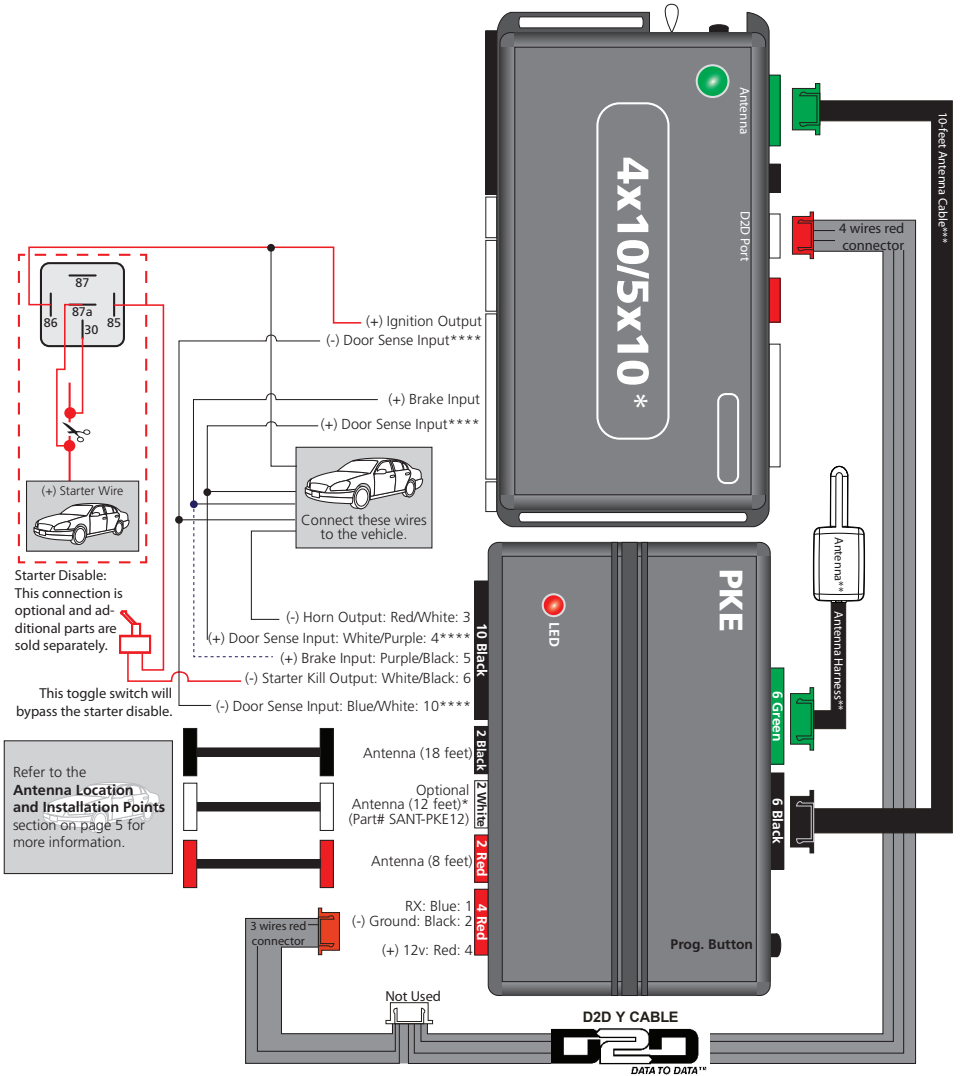

----- These wires are **not** required in D2D mode.

*Sold separately.

**Antenna & Antenna harness are sold with your Remote Starter kit.

***10-foot Antenna Cable is included in the PKE kit.

****Door sense: The polarity of the door sense in the vehicle will determine which wire to connect from the PKE to the DIRECTED Remote Starter.

Type 5 - PKE + Xpresskit Bypass

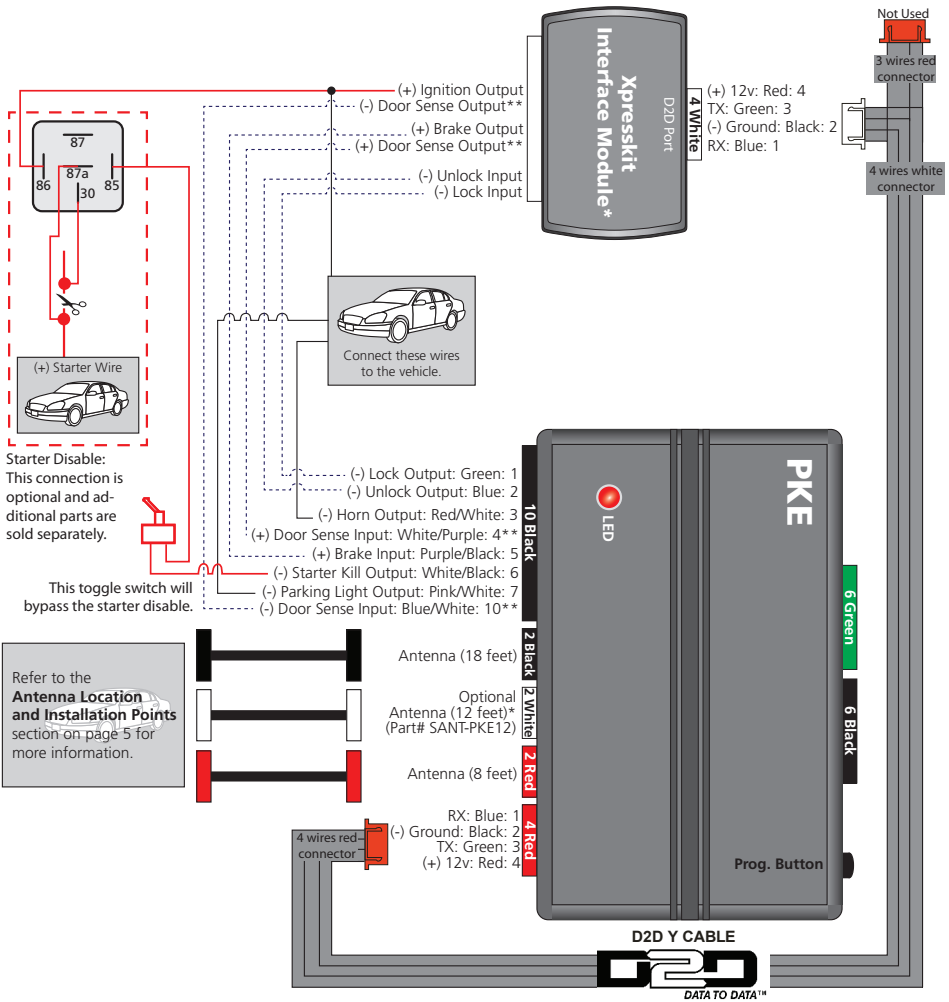

----- These wires are **not** required in D2D mode.

*Sold separately.

**Door sense: The polarity of the door sense in the vehicle will determine which wire to connect from the PKE to the DIRECTED Remote Starter.

Type 6 - PKE + DIRECTED SmartStart + 4x10/5x10

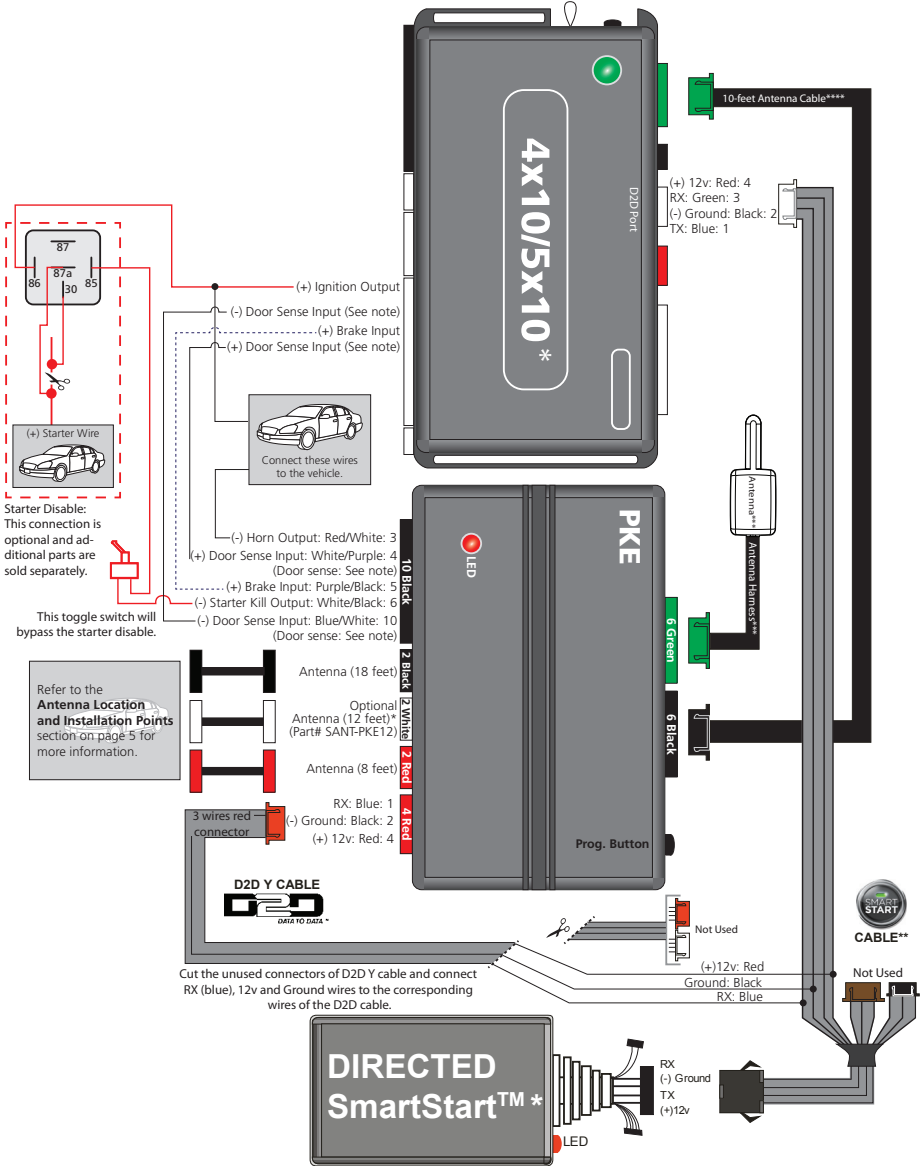

..... These wires are **not** required in D2D mode.

*Sold separately.

**DIRECTED SmartStart™ cable is sold with your DIRECTED SmartStart™.

***Antenna & Antenna harness are sold with your Remote Starter kit.

****10-foot Antenna Cable is included in the PKE kit.

Note: Door sense: The polarity of the door sense in the vehicle will determine which wire to connect from the PKE to the DIRECTED Remote Starter.

Type 7 - PKE + Xpresskit Bypass - Remote Start Ready (RSR) + DIRECTED SmartStart

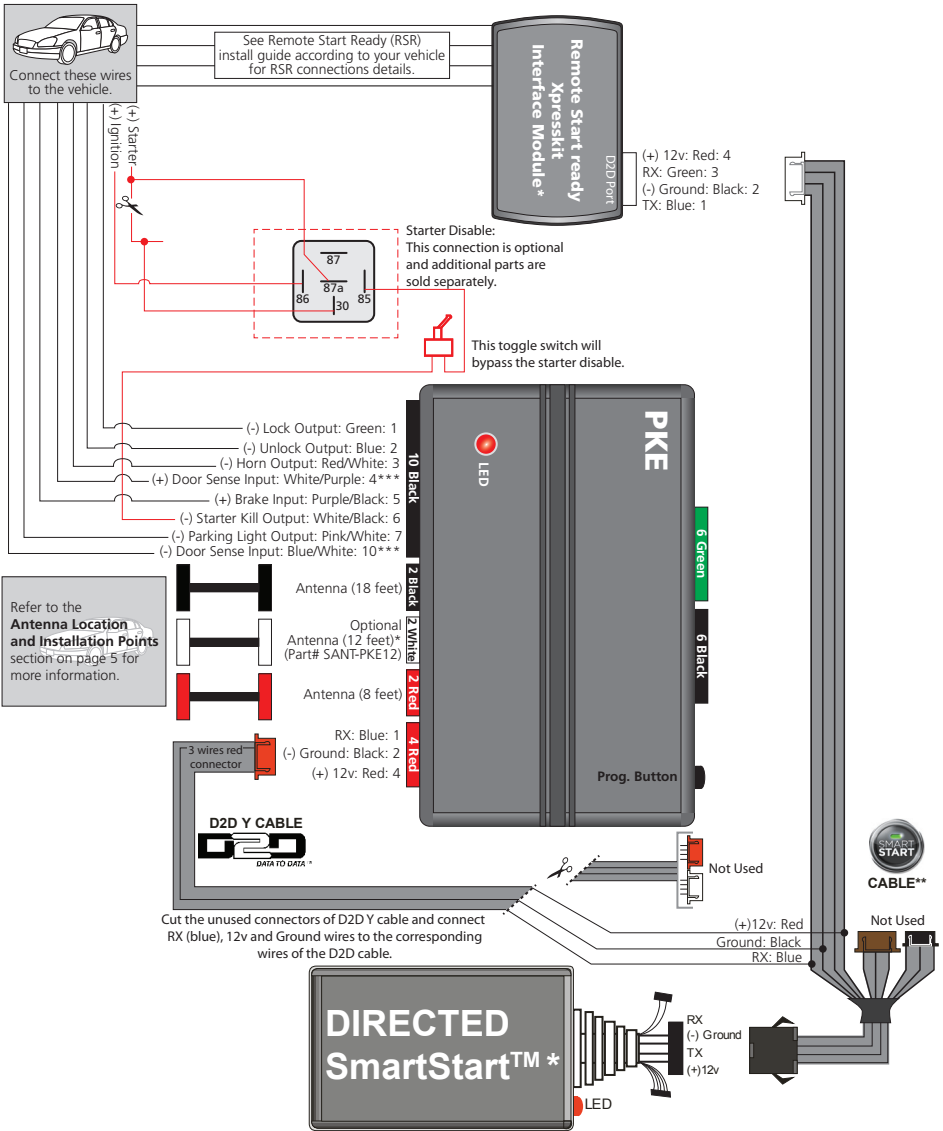

..... These wires are **not** required in D2D mode.

*Sold separately.

**DIRECTED SmartStart™ cable is sold with your SmartStart system.

***Door sense: The polarity of the door sense in the vehicle will determine which wire to connect from the PKE to the DIRECTED Remote Starter.

Type 8 - PKE + Xpresskit Bypass - Range Extender (RXT) + XL202

Note: 8210 Antenna Universal Adapter is required and sold separately.

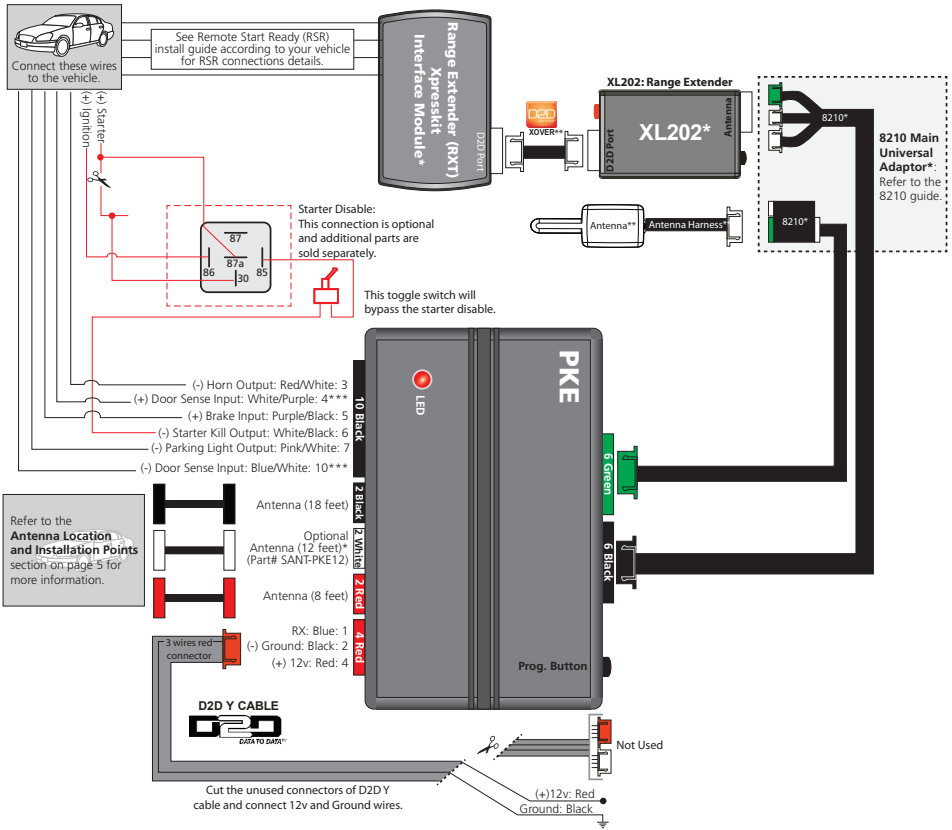

*Sold separately.

**D2D XOVER Cable, Antenna and Antenna Harness are sold with your RF Kit.

***Door sense: The polarity of the door sense in the vehicle will determine which wire to connect from the PKE to the DIRECTED Remote Starter.

Type 9 - PKE + AutoStart or AstroStart or Viper/Python/Clifford Directed Remote Starter (with 4pin antenna connector)

Note: 8210 Antenna Universal Adapter is required and sold separately.

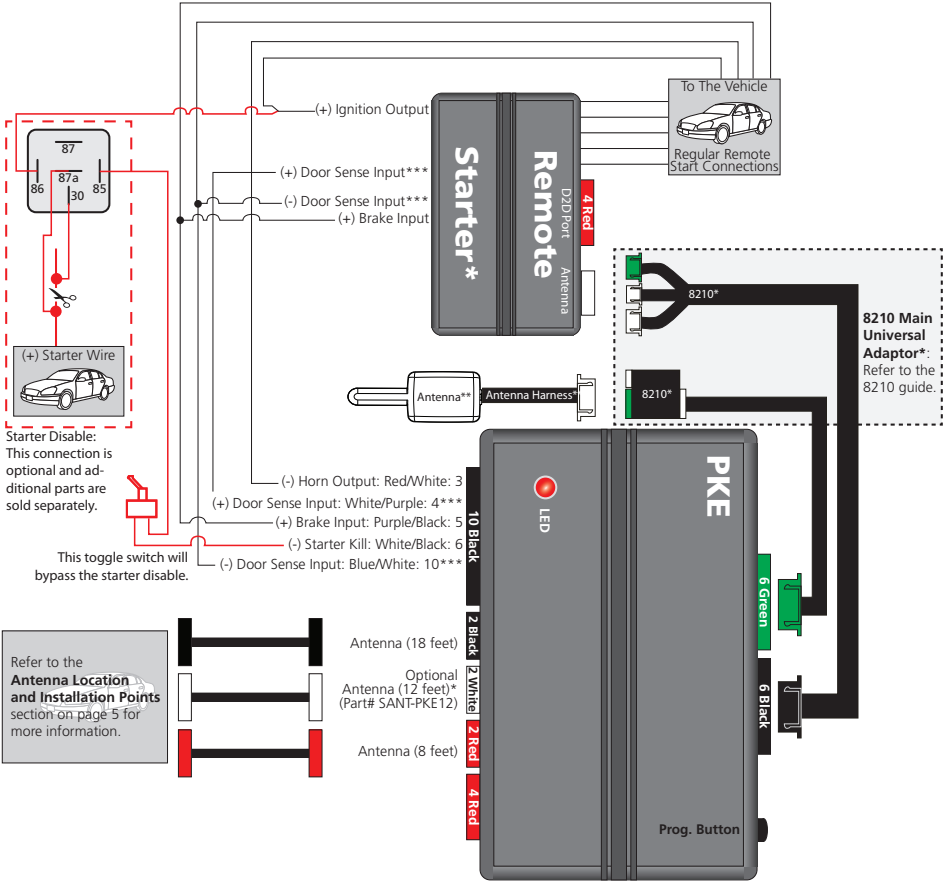

Starter Disable:
This connection is optional and additional parts are sold separately.

This toggle switch will bypass the starter disable.

Refer to the **Antenna Location and Installation Points** section on page 5 for more information.

*Sold separately.

**Antenna & Antenna harness are sold with your Remote Starter kit.

*** Door sense: The polarity of the door sense in the vehicle will determine which wire to connect from the PKE to the DIRECTED Remote Starter.

Wiring connections

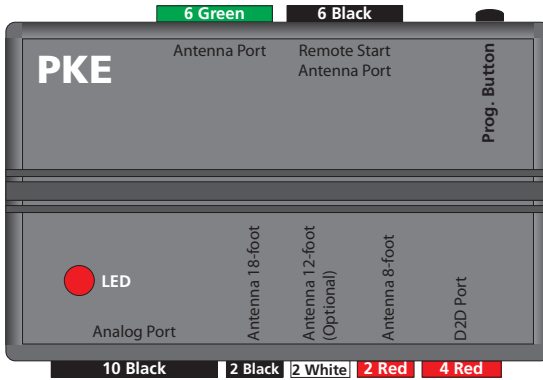

Analog Port (H1), 10-pin white connector

H1/1	GREEN	(-) LOCK OUTPUT
H1/2	BLUE	(-) UNLOCK OUTPUT
H1/3	RED/WHITE	(-) HORN OUTPUT
H1/4	WHITE/PURPLE	(+) DOOR SENSE INPUT*
H1/5	PURPLE/BLACK	(+) BRAKE INPUT
H1/6	WHITE/BLACK	(-) STARTER KILL OUTPUT
H1/7	PINK/WHITE	(-) PARKING LIGHTS OUTPUT
H1/8	PURPLE	No connection
H1/9	PINK	No connection
H1/10	BLUE/WHITE	(-) DOOR SENSE INPUT*

* Only one of the Door sense input is required for proper operation.

D2D port (H2), 4-pin black connector

H2/1	BLUE	RX
H2/2	BLACK	(-) GROUND
H2/3	GREEN	TX
H2/4	RED	(+) 12V

Feature Programming

The feature programming can be done by following the instructions below.

Entering feature programming routine

To select a Feature, press and release the programming button the corresponding number of times according to the table below, and then press and hold, the LED will flash to indicate the selected feature number.

To select this Feature number...	Press the programming button...	And the LED will flashes...
Feature 1	Twice	Once
Feature 2	3 times	Twice
Feature 3	4 times	3 times
Feature 4	5 times	4 times
Feature 5	6 times	5 times
Feature 6	7 times	6 times

Changing feature options

Press the programming button the corresponding number of times according to the selected option. The LED will flash the number of times according to the desired option. For example, if you select Option 3, you will press the programming button 3 times.

Accessing another feature

To change the option in another feature, wait 3 seconds after your last operation and the module will exit the menu programming. Repeat the steps in "Entering feature programming" and "Changing feature options" sections to select another feature and option.

Exiting feature programming

No activity for 3 seconds.

Features and Options List

Features	Options
1- RF Protocol Selection	1: Viper, Python, Clifford Supercode* Directed new generation receiver technology
	2: Viper, Python, Clifford Keeloq Directed older generation receiver technology
	3: AstroStart receiver technology
	4: AS HDR - FM AutoStart HDR (new style FM based) receiver technology
	5: AS HDR - AM AutoStart HDR (AM based) receiver technology
	6: AS LDR - FM AutoStart LDR (older style) receiver technology
2- Door Unlock Timing	1: 0.8 sec*
	2: 0.4 sec
	3: 3.5 sec
	4: Double pulse (0.25 sec)
3: Door Lock Timing	1: 0.8 sec*
	2: 0.4 sec
	3: 3.5 sec
	4: Double pulse (0.25 sec)
4: Number of Antenna	1: 2 Antennas (8ft - 18ft)*
	2: 3 Antennas (8ft - 12 ft - 18 ft)
	3: 1 Antenna (8ft)
5: Smart Lock**	1: 3 minutes timer*
	2: 0 minutes timer (No delay)
	3: 1 minute timer
	4: 5 minutes timer
6: Door Open Interlock	1: ON* The doors will lock as soon as the key fob leaves the zone even if a door is open.
	2: OFF The doors will not lock if the key fob leaves the zone while a door is open.

* Default option

** See SmartLock feature section for more details.

SmartLock feature

The purpose of the SmartLock feature is to prevent the doors from unwanted unlocking/locking when entering/exiting the active zone multiple times for a pre-programmed delay (No delay*, 1, 3 or 5 minutes). This is practical in situations such as loading/unloading packages.

*SmartLock feature is disabled when it is set to no delay, which is configurable.

Note: If the Door Open Interlock feature is enabled, the SmartLock feature will not be able to lock a door when it is left opened. For more information about using SmartLock feature, see owner's guide.

SmartLock feature diagram

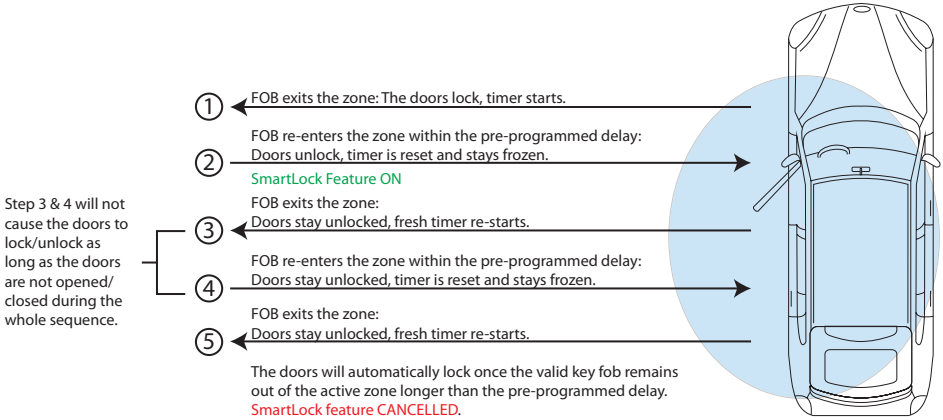

Remote pairing

Important:

The antennas must be connected to the PKE module before proceeding to pairing mode.

RF Protocols Selection need to be done prior to pair the PKE to the remote starter. See "Feature Programming" section on page 20.

Pairing the FOB to the PKE module:

1. Press and release, then press and hold the programming button on the PKE module. The LED will turn on solid indicating that the PKE module is in pairing mode.
2. Release the programming button.
3. **Quickly** press and release then press and hold the remote  button.
4. The fob LED will flash red followed by a green flash to confirm the pairing was successful.
5. If more than 1 red LED flash occurs during the programming process, verify antenna connections and repeat the pairing procedure.

Note: Press and release the programming button at any moment to exit remote pairing mode.

Pairing the PKE system to the remote starter module:

This step is necessary when a remote starter is installed prior to having a PKE system. This allows the remote starter to recognize commands from the PKE system. It is important that the FOB be paired to the PKE module first before proceeding with this step.

1. Place the remote starter in remote pairing mode (see the remote starter instructions on remote pairing for more information).
2. Press and hold the programming button on the PKE. The LED will flash 3 times to confirm that data is being sent to the remote starter.
3. Release the programming button. The remote starter will confirm the remote learning operation. Refer to the remote starter installation guide for more information on remote pairing.

Factory reset

To execute a factory reset:

1. Disconnect the power supply from the PKE module.
2. Press and hold the programming button.
3. Reconnect the power supply to the module. The LED will flash 5 times quickly to confirm factory reset.

Diagnostics

LED	Parking Lights	Flashing rate	Event
Flashes x 1	Flashes x 1	Slow	Lock
Flashes x 2	Flashes x 2	Slow	Unlock
Flashes x 3	Flashes x 3	Fast	Enabling PKE through FOB (Standalone installation only)
Flashes x 3	Flashes x 3	Slow	Remote ID being sent to remote starter
Flashes x 4	Flashes x 4	Slow	PKE learned
Flashes x 5	Flashes x 5	Fast	Disabling PKE through FOB (Standalone installation only)
Flashes x 5	Flashes x 5	Fast	Factory reset
ON continuously	N/A	ON continuously	PKE disabled

The company behind this system is Directed

Since its inception, Directed has had one purpose, to provide consumers with the finest vehicle security and car stereo products and accessories available. The recipient of nearly 100 patents and Innovations Awards in the field of advanced electronic technology.

Directed is ISO 9001 registered.

Quality Directed products are sold and serviced throughout North America and around the world.

Call (800) 274-0200 for more information about our products and services.

Designed and Engineered in the USA

DIRECTED[®]

N2102T 2012-07

Vista, CA 92081
www.directed.com

© 2012 Directed—All rights reserved