

GENERAL DESCRIPTION

SEAT BELT SYSTEM

1. General Description

A: COMPONENT

1. FRONT SEAT BELT

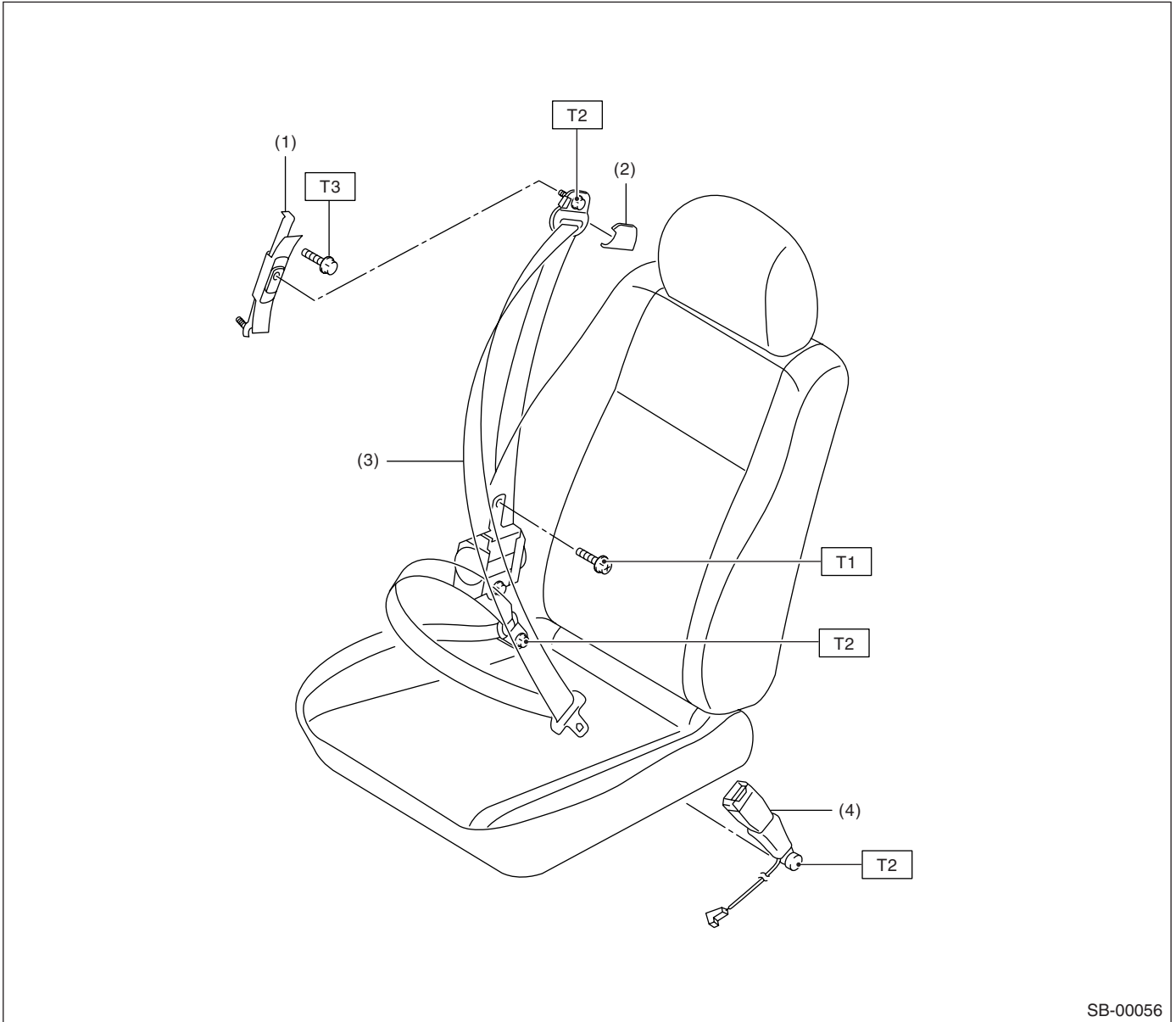

SB-00056

(1) Adjuster anchor ASSY

(3) Outer belt ASSY

(2) Anchor cover

(4) Inner belt ASSY

Tightening torque: N·m (kgf·m, ft·lb)

T1: 7.5 (0.76, 5.5)

T2: 30 (3.1, 22)

T3: 53 (5.4, 39)

2. REAR SEAT BELT

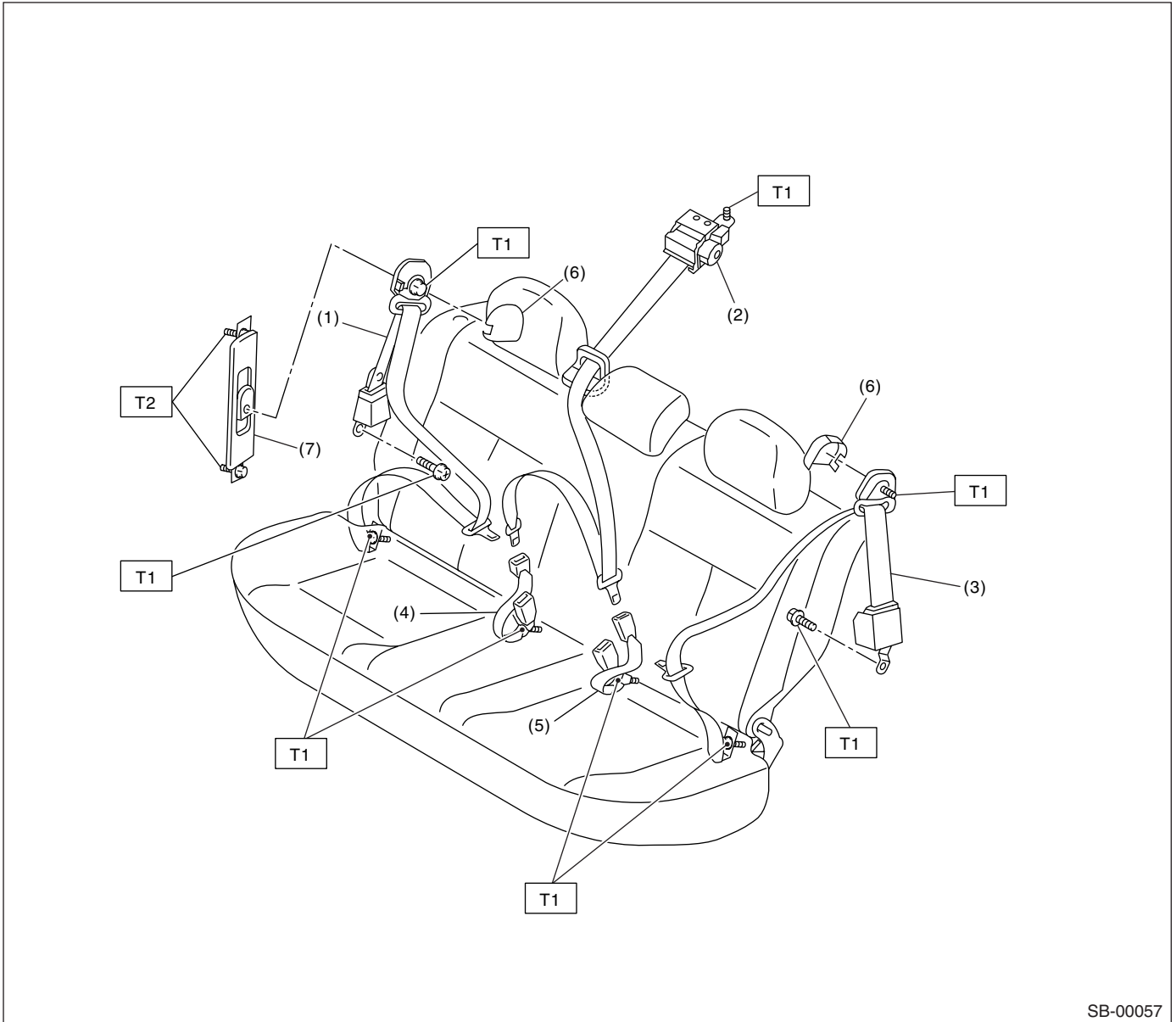

SB-00057

- | | |
|----------------------------|--------------------------|
| (1) Outer seat belt RH | (5) Inner seat belt LH |
| (2) Outer seat belt CENTER | (6) Anchor cover |
| (3) Outer seat belt LH | (7) Adjuster anchor ASSY |
| (4) Inner seat belt RH | |

Tightening torque: N·m (kgf·m, ft·lb)

T1: 30 (3.1, 22)

T2: 53 (5.4, 39)

GENERAL DESCRIPTION

SEAT BELT SYSTEM

B: CAUTION

- Before starting, turn the ignition switch to OFF, disconnect the battery ground cable and wait for 20 seconds or more.
- The pretension system has a backup power source. The pretensioner might deploy if you do not wait for 20 seconds or more before starting work.
- Do not drop or apply any impact to the pretensioner.
- If oil, grease, or water gets on the pretensioner, wipe it off immediately with a dry cloth.
- Do not expose the pretensioner to high temperature or flame.
- Do not allow current to flow through or voltage to reach the pretensioner. Do not use a circuit tester to check resistance of the pretensioner.
- Do not disassemble or attempt to repair the pretensioner. If it is dented, cracked, or deformed, replace it with a new one.
- Do not use the airbag or pretensioner parts from other vehicles. Always replace parts with new parts.
- When handling a seat belt with a deployed pretensioner, wear gloves and goggles. Wash your hands afterwards.
- Do not re-use a seat belt with a deployed pretensioner again.
- If the material gets in your eyes or on your skin during deployment, wash it away with clean water, and then consult a doctor.