



# Evaporative System Diagnosis

One of the last remaining sources of air pollution produced by vehicles occurs during refueling. As fuel is pumped into the tank, fuel vapors are displaced. Unless these vapors are trapped, they will escape into the atmosphere via the fuel filler neck.

Many jurisdictions now require the use of special gas pump filler nozzles, which capture the vapors as they escape. Many late model vehicles also incorporate an onboard refueling vapor recovery system, which captures the vapors before they have a chance to reach the filler neck. Subaru first added this capability to its vehicles during the 2000 model year.

Operation of the evaporative emissions and fuel recovery systems is monitored by the onboard diagnostic system (OBD II). The system periodically checks the system for leaks, to prevent vapors from escaping into the atmosphere. The system has the ability to detect a leak caused by a hole that is not much larger than a human hair in diameter.

If a leak is detected, the OBD II system will set a diagnostic trouble code (DTC). This is where you enter the picture. The source of the leak must be identified and repaired. If not, the DTC will

reset the next time the OBD II system runs its diagnostic checks. Testing the onboard refueling vapor recovery system involves checking all solenoids, valves and plumbing for air tightness, air flow and proper operation. A failure in any of these items will create a failure in the system.

The evaporative system pressure tester must be used with the Select Monitor (or a compatible aftermarket scan tool) to achieve the correct results. Begin by reading the warnings included with the special tool. Section by section testing will ensure all fittings, hoses, pipes, valves and components are tested.

## Evaporative Emission System Tester Component Legend

**PT** .... Pressure Tester  
**F** ..... Fuel  
**CPC**.. Canister Purge Control  
**FH**.... Fuel Hose  
**M**..... Manifold  
**PCV**.. Pressure Control Valve  
**D** .... Drain  
**V**..... Vent  
**SOV**.. Shut Off Valve  
**PS** .... Pressure Sensor

## Pressurizing the Tester

The following steps must be followed to pressurize the tester when instructed to do so:

1. Place the Pressure Hold in the open position.
2. Place the Vent in the closed position.
3. Turn the pump timer ON.
4. Observe the gauge.
5. When the highest pressure is reached, place the Pressure Hold in the closed position.
6. Turn the pump timer off.

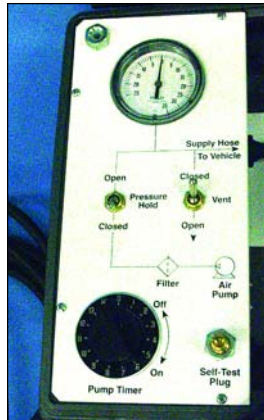

Evaporative System Pressure Tester

Abbreviation	Component	Location
CPC	Canister Purge Control Solenoid	Right under side of intake manifold.
PCV	Pressure control valve	Above rear differential.
D	Drain valve	Above canister right rear of vehicle.
SOV	Shut Off Valve	Located on the fuel filler neck behind the right rear inner fender.

Troubleshooting the evaporative emissions system involves a sequence of tests, listed below:

- Purge System Test
- Drain System Test
- Shut Off Valve Test
- Pressure Control Valve Test
- Fuel Tank and Vent Control Valve Test
- Canister

Follow the directions in each of the above tests. Complete all six tests to evaluate the entire evaporative system. Directions are included in each test to guide you through results that indicate a failure. Always complete the six tests, even if a failure has been identified and repaired early in the test sequence.



## Purge System Test

1. Disconnect CPC-1 from M-1.
2. Start the engine and check for a strong vacuum source at M-1.

3. Turn the engine off and ignition off.
4. Connect the Select Monitor to the data link connector.
5. Connect the inspection mode connectors.
6. Turn the ignition on and engine off.
7. Turn the Select Monitor on and adjust to the system operation check mode. Activate a component and turn it off to establish full control of all system operation check mode items.

Step 8 and 9 test the air tightness of the vacuum line from the intake manifold to the canister purge control solenoid. The air tightness of the solenoid is also checked at this time.

8. Connect PT-1 to CPC-1 and pressurize.

9. Did pressure hold?

If **YES**, go to step 10. If **NO**, go to step 10F.

## Purge System Test

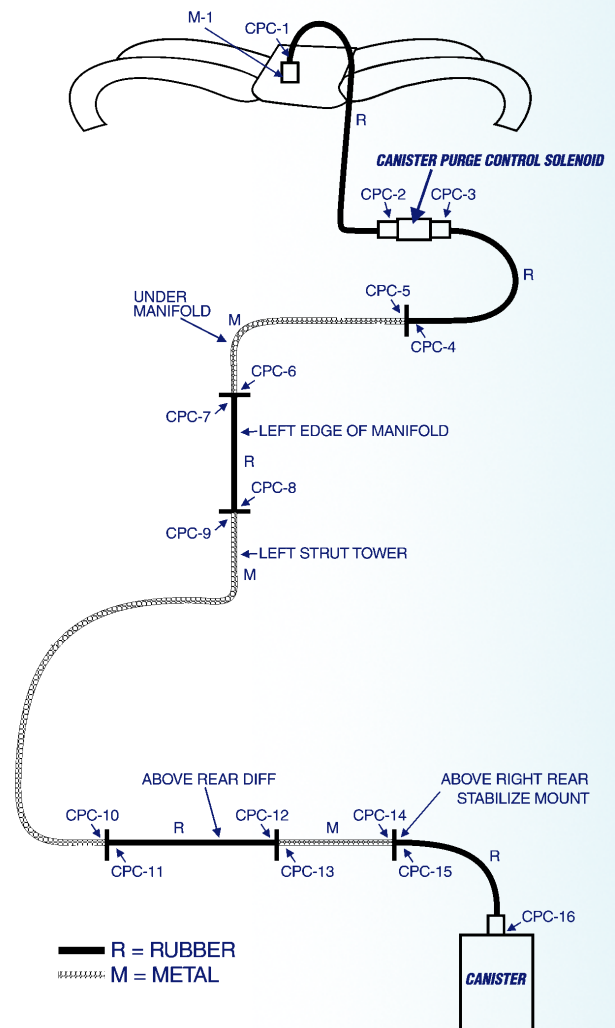

## Evaporative System Diagnosis

Step 10 and 11 test the electrical and mechanical operation of the canister purge control solenoid and the vacuum line from the output side of the solenoid to the canister for restrictions or blockages.

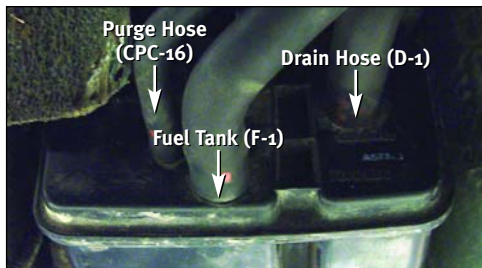

Canister with Hoses

10. Disconnect CPC-16 from the canister.
11. Activate the CPC solenoid with the Select Monitor.
12. Did pressure immediately go to zero?  
If **YES**, go to step 13. If **NO**, go to step 13F.

Step 13 and 14 test the vacuum hose from the canister purge control solenoid to the canister for air tightness.

13. Insert ST plug into CPC-16 to block the hose.
14. Pressurize.
15. Did pressure hold?  
If **YES**, go to step 16. If **NO**, go to step 16F.
16. Turn the CPC solenoid off with the Select Monitor.
17. Remove PT-1 from CPC-1.
18. Connect CPC-1 to M-1.
19. Remove the ST plug from CPC-16.
20. Connect CPC-16 to the canister.
21. Proceed to the Drain System Test.

### Purge Line Test 10F

- 10F. Disconnect CPC-2 from the CPC solenoid.
- 10F1. Connect ST plug to CPC-2.
- 10F2. Pressurize.
- 10F3. Does pressure hold?  
If **YES**, replace the CPC solenoid and go to Purge System Test step 8. If **NO**, replace hose and go to Purge System Test step 8.

### Purge Line Test 13F

- 13F. Turn off the CPC solenoid with the Select Monitor.
- 13F1. Disconnect CPC-4 from CPC-5.
- 13F2. Pressurize and turn on the CPC solenoid with the Select Monitor.
- 13F3. Does pressure go to zero immediately?  
If **NO**, go to step 13F4. If **YES**, go to step 13G.
- 13F4. Turn off the CPC solenoid with the Select Monitor and connect CPC-4 to CPC-5.
- 13F5. Disconnect CPC-3 from the CPC solenoid.
- 13F6. Pressurize.
- 13F7. Turn on the CPC solenoid with the Select Monitor.
- 13F8. Does pressure go to zero immediately?  
If **YES**, replace the hose between CPC-3 and CPC-4 and go to Purge System Test step 8. If **NO**, replace the CPC solenoid and go to Purge System Test step 8.

### Purge Line Test 13G

- 13G. Turn off the CPC solenoid with the Select Monitor.
- 13G1. Connect PT-1 to CPC-5.
- 13G2. Pressurize.
- 13G3. Disconnect CPC-8 from CPC-9.
- 13G4. Does pressure go to zero immediately?  
If **YES**, go to step 13H. If **NO**, go to step 13G5.
- 13G5. Pressurize.
- 13G6. Disconnect CPC-7 from CPC-8.
- 13G7. Does pressure go to zero immediately?  
If **YES**, replace the hose between CPC-7 and CPC-8 and go to Purge System Test step 8. If **NO**, an obstruction exists in the metal hose from CPC-5 to CPC-6. Clean and remove the obstruction or replace the hose. Then go to Purge System Test step 8.
- 13H. Connect Adapter-1 to PT-1.
- 13H1. Connect Adapter-1 to CPC-8.
- 13H2. Pressurize.
- 13H3. Disconnect CPC-12 from CPC-13.
- 13H4. Does pressure drop to zero immediately?  
If **YES**, go to step 13I. If **NO**, go to step 13H5.
- 13H5. Pressurize.
- 13H6. Disconnect CPC-10 from CPC-11.
- 13H7. Does pressure drop to zero immediately?  
If **YES**, replace the hose between CPC-11 and CPC-12 and go to Purge System Test step 8. If **NO**, an obstruction exists in the metal hose between CPC-10 and CPC-9. Clean and remove the obstruction or the replace hose. Then go to Purge System Test step 8.

### Purge Line Test 13I

- 13I. Connect Adapter-1 to CPC-13.
- 13I1. Pressurize.
- 13I2. Disconnect CPC-14 to CPC-15.
- 13I3. Did pressure drop to zero immediately?  
If **YES**, replace the hose between CPC-15 and CPC-16 and go to Purge System Test step 8. If **NO**, an obstruction exists in the metal hose between CPC-13 and CPC-14. Clean and remove the obstruction or replace the hose. Then go to Purge System Test step 8.

### Purge Line Test 16F

- 16F. Turn off the CPC solenoid with the Select Monitor.
- 16F1. Disconnect CPC-14 from CPC-15.
- 16F2. Connect Adapter-1 with ST plug to CPC-14.
- 16F3. Pressurize.
- 16F4. Turn on the CPC solenoid with the Select Monitor.
- 16F5. Does pressure hold?  
If **NO**, go to step 16F6. If **YES**, replace the hose between CPC-15 and CPC-16.
- 16F6. Turn off the CPC solenoid with the Select Monitor.
- 16F7. Disconnect CPC-12 and CPC-13.
- 16F8. Connect ST Plug to CPC-12.
- 16F9. Pressurize.
- 16F10. Turn on the CPC solenoid with the Select Monitor.
- 16F11. Does pressure hold?  
If **YES**, replace the metal hose between CPC-13 and CPC-14 and go to Purge System Test step 8. Ensure hoses

disconnected in prior step have been reconnected. If **NO**, go to 16F12.

16F12. Turn off the CPC solenoid with the Select Monitor.

16F13. Disconnect CPC-10 from CPC-11.

16F14. Connect Adapter-1 with ST plug to CPC-10.

16F15. Pressurize.

16F16. Turn on the CPC solenoid with the Select Monitor.

16F17. Does pressure hold?

If **YES**, replace the hose between CPC-11 and CPC-12 and go to Purge System Test step 8. If **NO**, go to 16F18.

### Purge Line Test 16F18

16F18. Turn off the CPC solenoid with the Select Monitor.

16F19. Disconnect CPC-8 from CPC-9.

16F20. Connect ST Plug to CPC-8.

16F21. Pressurize.

16F22. Turn on the CPC solenoid with the Select Monitor.

16F23. Does pressure hold?

If **YES**, replace the metal hose between CPC-9 and CPC-10 and go to Purge System Test step 8. Ensure hoses disconnected in prior step have been reconnected. If **NO**, go to step 16F24.

16F24. Turn off the CPC solenoid with the Select Monitor.

16F25. Disconnect CPC-6 from CPC-7.

16F26. Connect Adapter-1 with ST plug to CPC-6.

16F27. Pressurize.

16F28. Turn on the CPC solenoid with Select Monitor.

16F29. Does pressure hold?

### Purge Line Test 16F34

16F34. Does pressure hold?

If **YES**, replace the metal hose between CPC-5 and CPC-6 and go to Purge System Test step 8. If **NO**, go to step 16F35.

16F35. Disconnect CPC-3 from CPC solenoid.

16F36. Connect Adapter-1 with ST plug to CPC solenoid.

16F37. Pressurize.

16F38. Turn on the CPC solenoid with the Select Monitor.

16F39. Does pressure hold?

If **YES**, replace the hose between CPC-3 and CPC-4 and go to Purge System Test step 8. If **NO**, replace the CPC solenoid and go to Purge System Test step 8.

### Drain System Test

Steps 1 through 4 test the air tightness of the Adapter.

1. Disconnect D-1 from canister.
2. Connect PT-1 with ST Adapter-1.
3. Block ST Adapter-1 with ST Plug and pressurize.

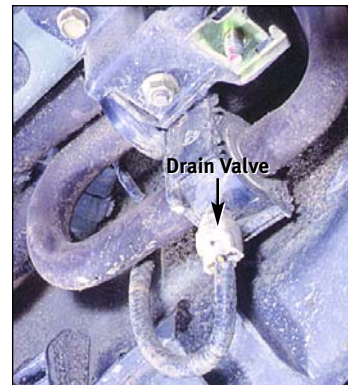

Drain Valve

## Drain System Test

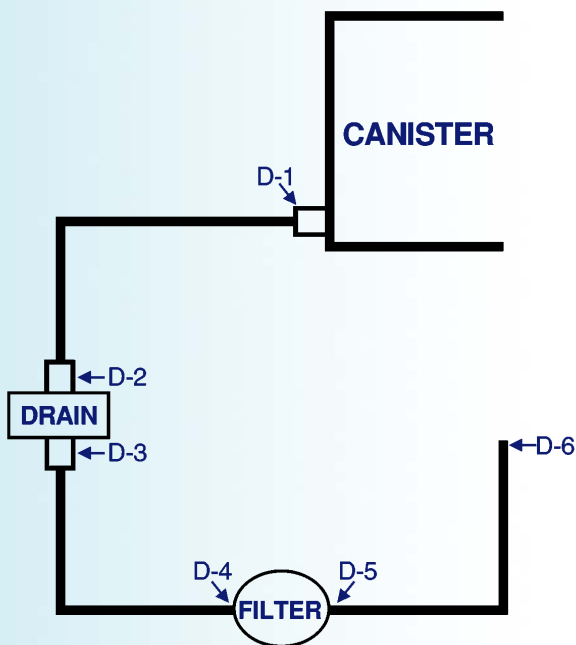

4. Does pressure hold?  
If **YES**, go to step 5. If **NO**, go to step 5F.
5. Remove ST-plug from ST Adapter-1.  
Step 6 and 7 will test the drain hoses, canister, drain valve and filter for restrictions and blockages.
6. Connect ST Adapter-1 with D-1 hose.
7. Pressurize.
8. Did pressure buildup?  
If **NO**, go to step 9. If **YES**, go to step 9F.  
Step 9 and 10 will test the air tightness of the vent hoses from the canister to the drain valve and the mechanical and electrical operation of the drain valve.
9. Activate vent valve solenoid with Select Monitor.
10. Pressurize.
11. Does pressure hold for the time the solenoid is on and then drop to zero?  
If **YES**, go to step 12. If **NO**, go to step 12F.
12. Turn off vent valve solenoid with Select Monitor.
13. Remove ST Adapter-1 from D-1.
14. Connect D-1 to canister.
15. Proceed to Shut Off Valve Test.

### Drain System Test 9F

- 9F. Disconnect D-5 from the filter.
- 9F1. Pressurize. Did pressure hold?  
If **YES**, go to step 9F2. If **NO**, replace the hose between D-5 and D-6 or remove the obstruction from the hose.
- 9F2. Disconnect D-4 from the filter.
- 9F3. Pressurize. Did pressure hold?  
If **YES**, go to step 9F4. If **NO**, replace the filter.
- 9F4. Disconnect D-3 from the Drain Valve.
- 9F5. Pressurize. Did pressure hold?

If **YES**, go to step 9F6. If **NO**, replace the hose from D-3 to D-4 or remove obstruction from hose.

9F6. Disconnect D-2 from the Drain Valve.

9F7. Pressurize. Did pressure hold?

If **YES**, replace the hose from D-1 to D-2 or remove obstruction from hose. If **NO**, replace the Drain Valve. Reconnect all hoses.

### Shut Off Valve Test

Step 1 through 4 test the vacuum hose from SOV-12 to the shut off valve, the shut off valve itself, and the vacuum hose from the shut off valve to the pressure control valve for restrictions and blockages. Refer to the diagram on page 12.

1. Disconnect SOV-12 from F-4.
2. Disconnect PCV-1 from PCV.
3. Connect PT-1 to SOV-12.
4. Pressurize.
5. Does pressure build up?  
If **NO**, go to step 6. If **YES**, go to step 6F.

Step 6 and 7 will test the air tightness of the vacuum hose from SOV-12 to the shut off valve, the shut off valve itself, and the vacuum hose from the shut off valve to the pressure control valve. The shut-off valve itself is not 100% airtight. Pressure will leak slightly from the shut-off valve to the inside of the fuel neck.

6. Connect ST Plug to PCV-1.
7. Pressurize.
8. Does pressure slowly go to zero?  
If **YES**, go to step 9. If **NO**, go to step 9F.
9. Remove PT-1 from SOV-12 and connect SOV-12 to F-4.
10. Proceed to Pressure Control Valve Test.

### Shut Off Valve Test 6F

- 6F. Pressurize.
- 6F1. Disconnect SOV-11 from SOV-10.
- 6F2. Does pressure build up?  
If **YES**, replace the hose between SOV-12 and SOV-11 and go to Shut Off Valve Test step 3. If **NO**, connect SOV-11 to SOV-10 and go to step 6F3.
- 6F3. Pressurize.
- 6F4. Disconnect SOV-8 from SOV-9.
- 6F5. Does pressure build up?  
If **YES**, clean or replace the metal hose between SOV-1 and SOV-9 and go to Shut Off Valve Test step 3. If **NO**, connect SOV-8 to SOV-9 and go to step 6F6.
- 6F6. Pressurize.
- 6F7. Disconnect SOV-7 from the Fuel Shut Valve.
- 6F8. Does pressure build up?  
If **YES**, replace the hose between SOV-8 and SOV-7 and go to Shut Off Valve Test step 3. If **NO**, connect SOV-7 to the Fuel Shut Valve.
- 6F9. Pressurize.
- 6F10. Disconnect SOV-1 from the Fuel Shut Valve.
- 6F11. Does pressure build up?  
If **YES**, replace the Fuel Shut Valve and go to Shut Off Valve Test step 3. If **NO**, connect SOV-1 to the Fuel Shut Valve and go to step 6F12.

### Shut Off Valve Test 6F12

6F12. Pressurize.

6F13. Disconnect SOV-2 from SOV-3.

6F14. Does pressure build up?

If **YES**, replace the hose between SOV-1 and SOV-2 and go to Shut Off Valve Test step 3. If **NO**, clean or replace the metal hose between SOV-3 and SOV-4 and go to Shut Off Valve Test step 3.

### Shut Off Valve Test 9F

9F. Go to step 9G.

### Shut Off Valve Test 9G

9G. Disconnect SOV-4 from SOV-5.

9G1. Connect Adapter-1 with ST plug to SOV-4.

9G2. Did pressure hold?

If **YES**, replace the rubber hose between PCV-1 and SOV-5 and go to Shut Off Valve Test step 6. If **NO**, go to step 9G3.

9G3. Disconnect SOV-2 from SOV-3.

9G4. Connect ST plug to SOV-2.

9G5. Pressurize. Did pressure hold?

If **YES**, replace the metal hose between SOV-3 and SOV-4 and go to Shut Off Valve Test step 6. If **NO**, go to step 9G6.

9G6. Disconnect SOV-1 from the Shut Off Valve.

9G7. Connect Adapter-1 with ST plug to the Shut Off Valve.

9G8. Pressurize. Did pressure hold?

If **YES**, replace the rubber hose from SOV-1 to SOV-2 and go to Shut Off Valve Test step 6. If **NO**, go to step 9G9.

9G9. Disconnect SOV-7 from the Shut Off Valve and connect ST plug to SOV-7. Pressurize. Does pressure hold?

If **YES**, replace the Shut Off Valve and go to Shut Off Valve Test step 6. If **NO**, go to step 9G10.

9G10. Disconnect SOV-8 from SOV-9.

9G11. Connect Adapter-1 with ST plug to SOV-9.

9G12. Pressurize. Does pressure hold?

If **YES**, replace the rubber hose between SOV-7 and SOV-8 and go to Shut Off Valve Test step 6. If **NO**, go to step 9G13.

9G13. Disconnect SOV-10 from SOV-11.

9G14. Connect the ST plug to SOV-11.

9G15. Pressurize. Does pressure hold?

If **YES**, replace the metal hose between SOV-10 and SOV-9 and go to Shut Off Valve Test step 6. If **NO**, replace the rubber hose between SOV-11 and SOV-12 and go to Shut Off Valve Test step 6.

## Shut Off Valve Test and Pressure Control Valve Test

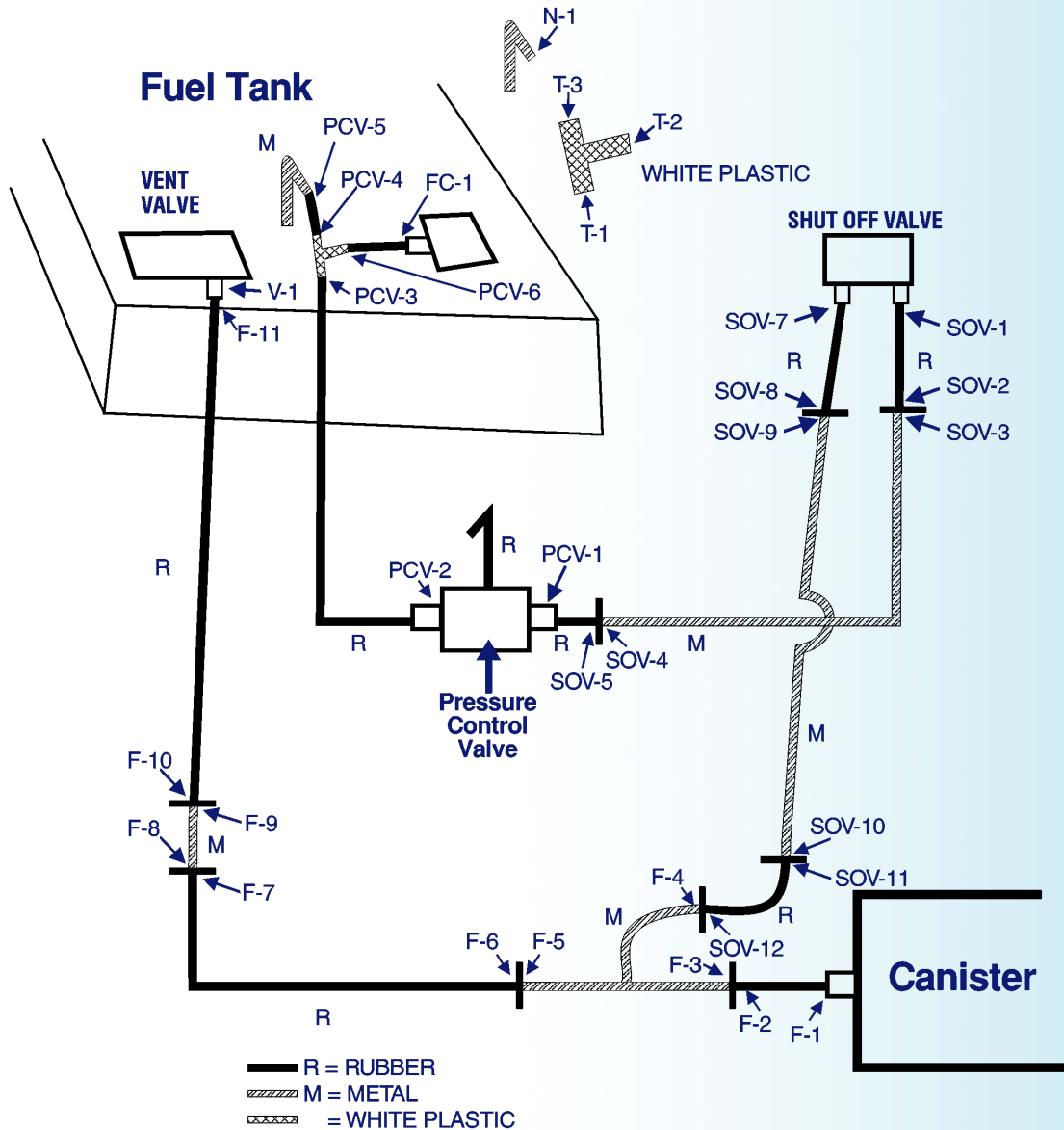

### Pressure Control Valve Test

Step 1 through 8 will test the Pressure control valve for electrical and mechanical operation.

1. Remove ST plug from PCV-1.
2. Connect PT-1 with ST Adapter-1.
3. Disconnect PCV-2 from PCV.
4. Connect Adapter-1 to PCV, applying pressure where PCV-2 connects to PCV.
5. Activate PCV solenoid with Select Monitor.
6. Turn pump timer on with HOLD SWITCH to OPEN position.
7. Does pressure build to approximately 21, then fluctuates by 1 as solenoid turns on and off? If YES, go to step 8. If NO, replace PCV and go to step

1. Turn the pump timer off. Turn the pressure control valve off with the Select Monitor.

8. Step 8 tests the PCV for air tightness. Block PCV at PCV-1 and pressurize. Did pressure hold? If YES, go to step 9. If NO, replace the PCV and go to step 1.
9. Turn pump timer off.
10. Turn off PCV with Select Monitor.
11. Remove ST plug from PCV.
12. Remove PT-1 with ST Adapter-1 from PCV.
13. Connect PCV-1 to PCV.
14. Connect PCV-2 to PCV.
15. Proceed to Fuel Tank and Vent Control Valve Test.

### Fuel Tank and Vent Control Valve Test

**Warning: The next step introduces fuel vapors into the atmosphere. Test in well ventilated space. No Smoking!**

Steps 1 through 9 tests the air tightness of the fuel tank, lines, and items shown in the illustration.

**Warning: The pressure introduced into the fuel tank by the tester can push fuel from an open fuel line into the atmosphere.**

- Adjust the Select Monitor to read the fuel tank pressure.
- Check and record the fuel tank pressure. (With the cap off the pressure should be near zero.)
- Pressure higher or lower than zero could indicate a blockage in the PS-3 hose, PS-2 hose, the fuel tank passage or a failure of the pressure sensor.

1. Remove Fuel Cap and connect cap to Adapter-2.



Adapter 2 and Pressure Tester Hose

2. Connect opposite end of Adapter-2 to filler neck.
3. Remove PT-1 from hose and connect to threaded portion of Adapter-2.
4. Disconnect F-1 from canister.
5. Connect Adapter-1 with ST plug to F-1.
6. Loosen connection V-7. Do not remove at this time.
7. Pressurize.



Purge (CPC-16) and Fuel (F-1) Hoses

Check and record the fuel tank pressure. At 24 in HG on the tester pressure gauge, the pressure reading on the Select Monitor should be +0.91 in HG or +23.3 mm HG.

If the pressure is not within specifications check the PS-3 hose for restrictions or blockage, and the PS-2 hose for restrictions, blockage and leaks.



Fuel Neck with Shut Off Valve and (V-7)



## Evaporative System Diagnosis

Confirm that the fuel tank passage located at PS-1 is allowing fuel tank pressure to exit the tank.

8. **Warning: Next step introduces fuel vapors into the atmosphere.**
9. After 2 minutes, does pressure hold?  
If **YES**, go to step 10. If **NO**, go to step 10F.

Step 10 and 11 will test the mechanical operation of the Vent control valve.

10. Listen to the sound of air leaving the tank as Adapter-1 with ST plug is removed from F-1.
11. Listen to the sound of air leaving the tank as V-7 is disconnected.
12. Did the speed of air escaping the tank increase from steps 10 to 11?  
If **YES**, go to step 13. If **NO**, go to step 13F.
13. Connect V-7 to filler neck.
14. Proceed to Canister Test.

### Fuel Tank and Vent Control Valve Test 10F

- 10F. Check all fuel lines, fuel cap and evaporative lines for proper connection.
- 10F1. Remove all fuel and tank pressure.
- 10F2. Follow instructions in the appropriate Subaru service manual for removing the fuel tank.
- 10F3. Plug all inlets and outlets from the fuel tank and external valves.
- 10F4. Ensure the fuel tank is at least half full and pressurize.
- 10F5. After leak has been found and repaired go to 10F6.
- 10F6. Pressurize.

### Warning: The next step introduces fuel vapors into the atmosphere.

- 10F7. After two minutes, does pressure hold?  
If **YES**, go to step 10F8. If **NO**, recheck for leaks and go to 10F5.
- 10F8. The following steps will check the operation of the vent control valve. This should be performed before installing the

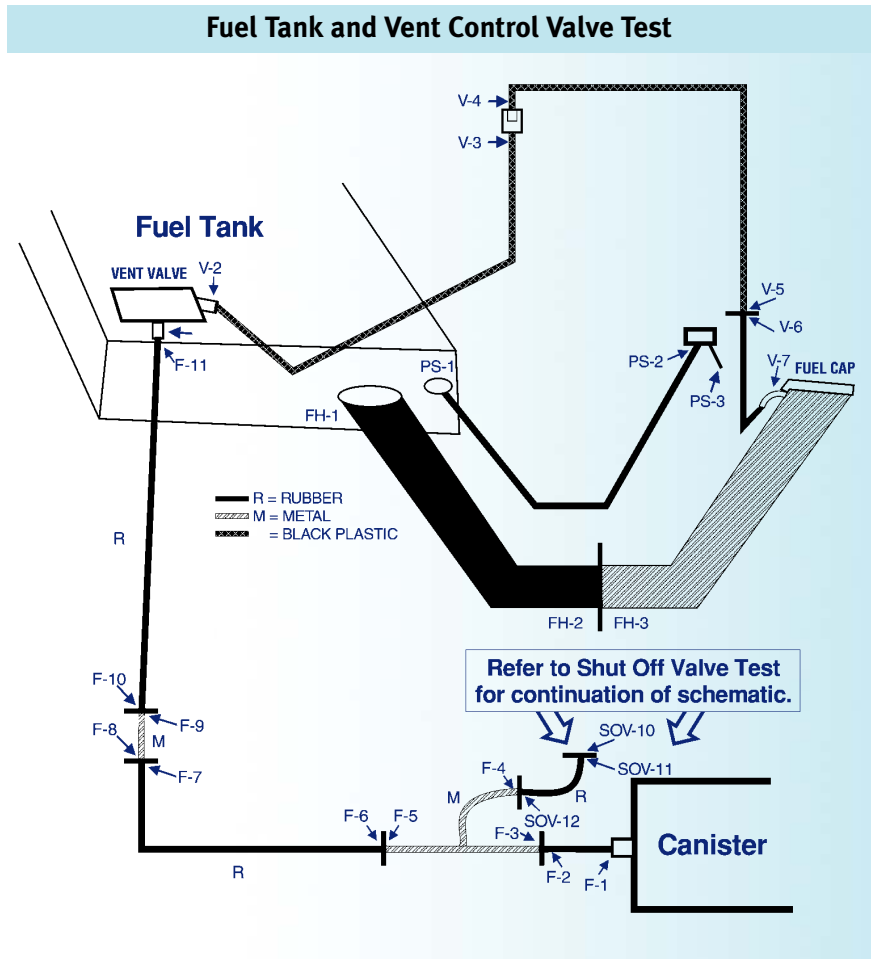

- tank because the tank must be removed to replace a faulty valve. Steps 10F9. through 10F11 test the mechanical operation of the Vent Control Valve.
- 10F9. Listen to the sound of air leaving the tank as plug for F-11 is removed.
- 10F10. Listen to the sound of air leaving the tank as the plug for V-2 is disconnected.
- 10F11. Did the speed of air escaping the tank increase from steps 10F9 to 10F10?  
If **YES**, remove all fuel and tank pressure and install the tank, using instructions from the appropriate Subaru service manual. If **NO**, remove all fuel and tank pressure and replace the Vent Control Valve using instructions from the appropriate Subaru service manual.  
Note: If tank has been removed, perform Fuel Tank and Vent Control

Valve Test steps 1 through 13 to confirm air tightness of the fuel tank and Vent Control Valve after installation.

### Fuel Tank and Vent Control Valve Test 13F

- 13F. Remove all tank pressure.
- 13F1. Remove V-7 from the fuel neck and connect PT-1.
- 13F3. Remove V-2 from the Vent Control Valve.
- 13F4. Pressurize. Did pressure hold?  
If **YES**, replace or remove the obstruction from the rubber hose between V-7 and V-2 and go to Fuel Tank and Vent Control Valve Test step 7. If **NO**, go to 13F5.
- 13F5. Insert the ST Plug into the V-2 hose.
- 13F6. Pressurize. Did pressure hold?  
If **YES**, remove all fuel and tank pressure and replace the Vent Control Valve using instructions from the appropriate Subaru service manual. If

**NO**, replace the rubber hose between V-7 and V-2 and go to Fuel Tank and Vent Control Valve Test step 7.

Note: If the tank has been removed, perform Fuel Tank and Vent Control Valve Test steps 1 through 13 to confirm air tightness of the fuel tank and Vent Control Valve after installation.

### Canister Test

Steps 1 through 8 tests the air tightness of the canister. Disconnect all three hoses from the canister.

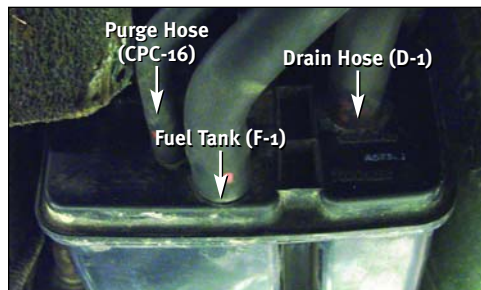

Canister with Hoses

### Canister Test

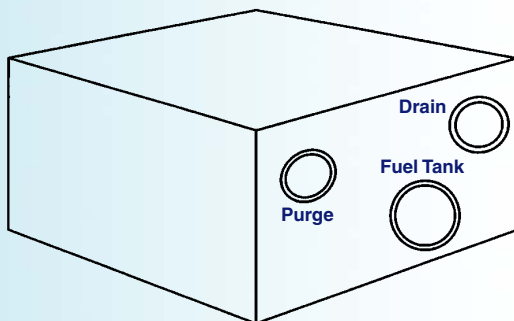

1. Reinstall PT-1 to pressure tester hose.
2. Connect Adapter-1 to PT-1.
3. Connect Adapter-1 to purge hose connection of canister.
4. Connect Adapter-3 to fuel tank hose connection of canister.
5. Connect Adapter-4 to Drain hose connection of canister.
6. Pressurize.
7. After two minutes, does pressure hold?  
If **YES**, go to step 9. If **NO**, go to step 9F.
8. Disconnect three Adapters from canister.
9. Connect all hoses back to canister and secure.