

# **GENERAL DESCRIPTION**

# List of Diagnostic Trouble Code (DTC)

## GENERAL DESCRIPTION

### 1. List of Diagnostic Trouble Code (DTC)

#### A: LIST

DTC	Item	Index
P0026	Intake Valve Control Solenoid Circuit Range/Performance (Bank 1)	<Ref. to GD(H4SO)-8, DTC P0026 INTAKE VALVE CONTROL SOLENOID CIRCUIT RANGE/PERFORMANCE (BANK 1), Diagnostic Trouble Code (DTC) Detecting Criteria.>
P0028	Intake Valve Control Solenoid Circuit Range/Performance (Bank 2)	<Ref. to GD(H4SO)-10, DTC P0028 INTAKE VALVE CONTROL SOLENOID CIRCUIT RANGE/PERFORMANCE (BANK 2), Diagnostic Trouble Code (DTC) Detecting Criteria.>
P0030	HO2S Heater Control Circuit (Bank 1 Sensor 1)	<Ref. to GD(H4SO)-11, DTC P0030 HO2S HEATER CONTROL CIRCUIT (BANK 1 SENSOR 1), Diagnostic Trouble Code (DTC) Detecting Criteria.>
P0031	HO2S Heater Control Circuit Low (Bank 1 Sensor 1)	<Ref. to GD(H4SO)-12, DTC P0031 HO2S HEATER CONTROL CIRCUIT LOW (BANK 1 SENSOR 1), Diagnostic Trouble Code (DTC) Detecting Criteria.>
P0032	HO2S Heater Control Circuit High (Bank 1 Sensor 1)	<Ref. to GD(H4SO)-14, DTC P0032 HO2S HEATER CONTROL CIRCUIT HIGH (BANK 1 SENSOR 1), Diagnostic Trouble Code (DTC) Detecting Criteria.>
P0037	HO2S Heater Control Circuit Low (Bank 1 Sensor 2)	<Ref. to GD(H4SO)-16, DTC P0037 HO2S HEATER CONTROL CIRCUIT LOW (BANK 1 SENSOR 2), Diagnostic Trouble Code (DTC) Detecting Criteria.>
P0038	HO2S Heater Control Circuit High (Bank 1 Sensor 2)	<Ref. to GD(H4SO)-17, DTC P0038 HO2S HEATER CONTROL CIRCUIT HIGH (BANK 1 SENSOR 2), Diagnostic Trouble Code (DTC) Detecting Criteria.>
P0068	Manifold Absolute Pressure/Barometric Pressure Circuit Range/Performance	<Ref. to GD(H4SO)-19, DTC P0068 MANIFOLD PRESSURE SENSOR RANGE/PERFORMANCE, Diagnostic Trouble Code (DTC) Detecting Criteria.>
P0076	Intake Valve Control Solenoid Circuit Low (Bank 1)	<Ref. to GD(H4SO)-21, DTC P0076 INTAKE VALVE CONTROL CIRCUIT LOW (BANK 1), Diagnostic Trouble Code (DTC) Detecting Criteria.>
P0077	Intake Valve Control Solenoid Circuit High (Bank 1)	<Ref. to GD(H4SO)-22, DTC P0077 INTAKE VALVE CONTROL CIRCUIT HIGH (BANK 1), Diagnostic Trouble Code (DTC) Detecting Criteria.>
P0082	Intake Valve Control Solenoid Circuit Low (Bank 2)	<Ref. to GD(H4SO)-23, DTC P0082 INTAKE VALVE CONTROL CIRCUIT LOW (BANK 2), Diagnostic Trouble Code (DTC) Detecting Criteria.>
P0083	Intake Valve Control Solenoid Circuit High (Bank 2)	<Ref. to GD(H4SO)-23, DTC P0083 INTAKE VALVE CONTROL CIRCUIT HIGH (BANK 2), Diagnostic Trouble Code (DTC) Detecting Criteria.>
P0101	Mass or Volume Air Flow Circuit Range/Performance	<Ref. to GD(H4SO)-23, DTC P0101 MASS OR VOLUME AIR FLOW CIRCUIT RANGE/PERFORMANCE, Diagnostic Trouble Code (DTC) Detecting Criteria.>
P0102	Mass or Volume Air Flow Circuit Low Input	<Ref. to GD(H4SO)-25, DTC P0102 MASS OR VOLUME AIR FLOW CIRCUIT LOW INPUT, Diagnostic Trouble Code (DTC) Detecting Criteria.>
P0103	Mass or Volume Air Flow Circuit High Input	<Ref. to GD(H4SO)-26, DTC P0103 MASS OR VOLUME AIR FLOW CIRCUIT HIGH INPUT, Diagnostic Trouble Code (DTC) Detecting Criteria.>
P0107	Manifold Absolute Pressure/Barometric Pressure Circuit Low Input	<Ref. to GD(H4SO)-28, DTC P0107 MANIFOLD ABSOLUTE PRESSURE/BAROMETRIC PRESSURE CIRCUIT LOW INPUT, Diagnostic Trouble Code (DTC) Detecting Criteria.>
P0108	Manifold Absolute Pressure/Barometric Pressure Circuit High Input	<Ref. to GD(H4SO)-29, DTC P0108 MANIFOLD ABSOLUTE PRESSURE/BAROMETRIC PRESSURE CIRCUIT HIGH INPUT, Diagnostic Trouble Code (DTC) Detecting Criteria.>
P0111	Intake Air Temperature Circuit Range/Performance	<Ref. to GD(H4SO)-30, DTC P0111 INTAKE AIR TEMPERATURE CIRCUIT RANGE/PERFORMANCE, Diagnostic Trouble Code (DTC) Detecting Criteria.>
P0112	Intake Air Temperature Circuit Low Input	<Ref. to GD(H4SO)-32, DTC P0112 INTAKE AIR TEMPERATURE CIRCUIT LOW INPUT, Diagnostic Trouble Code (DTC) Detecting Criteria.>
P0113	Intake Air Temperature Circuit High Input	<Ref. to GD(H4SO)-33, DTC P0113 INTAKE AIR TEMPERATURE CIRCUIT HIGH INPUT, Diagnostic Trouble Code (DTC) Detecting Criteria.>
P0117	Engine Coolant Temperature Circuit Low Input	<Ref. to GD(H4SO)-35, DTC P0117 ENGINE COOLANT TEMPERATURE CIRCUIT LOW INPUT, Diagnostic Trouble Code (DTC) Detecting Criteria.>

# List of Diagnostic Trouble Code (DTC)

GENERAL DESCRIPTION

DTC	Item	Index
P0118	Engine Coolant Temperature Circuit High Input	<Ref. to GD(H4SO)-36, DTC P0118 ENGINE COOLANT TEMPERATURE CIRCUIT HIGH INPUT, Diagnostic Trouble Code (DTC) Detecting Criteria.>
P0122	Throttle/Pedal Position Sensor/Switch "A" Circuit Low Input	<Ref. to GD(H4SO)-38, DTC P0122 THROTTLE/PEDAL POSITION SENSOR/SWITCH "A" CIRCUIT LOW INPUT, Diagnostic Trouble Code (DTC) Detecting Criteria.>
P0123	Throttle/Pedal Position Sensor/Switch "A" Circuit High Input	<Ref. to GD(H4SO)-39, DTC P0123 THROTTLE/PEDAL POSITION SENSOR/SWITCH "A" CIRCUIT HIGH INPUT, Diagnostic Trouble Code (DTC) Detecting Criteria.>
P0125	Insufficient Coolant Temperature for Closed Loop Fuel Control	<Ref. to GD(H4SO)-40, DTC P0125 INSUFFICIENT COOLANT TEMPERATURE FOR CLOSED LOOP FUEL CONTROL, Diagnostic Trouble Code (DTC) Detecting Criteria.>
P0126	Insufficient Coolant Temperature for Stable Operation	<Ref. to GD(H4SO)-42, DTC P0126 INSUFFICIENT ENGINE COOLANT TEMPERATURE FOR STABLE OPERATION, Diagnostic Trouble Code (DTC) Detecting Criteria.>
P0128	Coolant Thermostat (Coolant Temperature Below Thermostat Regulating Temperature)	<Ref. to GD(H4SO)-44, DTC P0128 COOLANT THERMOSTAT (COOLANT TEMPERATURE BELOW THERMOSTAT REGULATING TEMPERATURE), Diagnostic Trouble Code (DTC) Detecting Criteria.>
P0131	O <sub>2</sub> Sensor Circuit Low Voltage (Bank 1 Sensor 1)	<Ref. to GD(H4SO)-46, DTC P0131 O <sub>2</sub> SENSOR CIRCUIT LOW VOLTAGE (BANK 1 SENSOR 1), Diagnostic Trouble Code (DTC) Detecting Criteria.>
P0132	O <sub>2</sub> Sensor Circuit High Voltage (Bank 1 Sensor 1)	<Ref. to GD(H4SO)-47, DTC P0132 O <sub>2</sub> SENSOR CIRCUIT HIGH VOLTAGE (BANK 1 SENSOR 1), Diagnostic Trouble Code (DTC) Detecting Criteria.>
P0133	O <sub>2</sub> Sensor Circuit Slow Response (Bank 1 Sensor 1)	<Ref. to GD(H4SO)-49, DTC P0133 O <sub>2</sub> SENSOR CIRCUIT SLOW RESPONSE (BANK 1 SENSOR 1), Diagnostic Trouble Code (DTC) Detecting Criteria.>
P0134	O <sub>2</sub> Sensor Circuit No Activity Detected (Bank 1 Sensor 1)	<Ref. to GD(H4SO)-51, DTC P0134 O <sub>2</sub> SENSOR CIRCUIT NO ACTIVITY DETECTED (BANK 1 SENSOR 1), Diagnostic Trouble Code (DTC) Detecting Criteria.>
P0137	O <sub>2</sub> Sensor Circuit Low Voltage (Bank 1 Sensor 2)	<Ref. to GD(H4SO)-53, DTC P0137 O <sub>2</sub> SENSOR CIRCUIT LOW VOLTAGE (BANK 1 SENSOR 2), Diagnostic Trouble Code (DTC) Detecting Criteria.>
P0138	O <sub>2</sub> Sensor Circuit High Voltage (Bank 1 Sensor 2)	<Ref. to GD(H4SO)-56, DTC P0138 O <sub>2</sub> SENSOR CIRCUIT HIGH VOLTAGE (BANK 1 SENSOR 2), Diagnostic Trouble Code (DTC) Detecting Criteria.>
P0139	O <sub>2</sub> Sensor Circuit Slow Response (Bank 1 Sensor 2)	<Ref. to GD(H4SO)-56, DTC P0139 O <sub>2</sub> SENSOR CIRCUIT SLOW RESPONSE (BANK 1 SENSOR 2), Diagnostic Trouble Code (DTC) Detecting Criteria.>
P0140	O <sub>2</sub> Sensor Circuit No Activity Detected (Bank1 Sensor 2)	<Ref. to GD(H4SO)-62, DTC P0140 O <sub>2</sub> SENSOR CIRCUIT NO ACTIVITY DETECTED (BANK1 SENSOR 2), Diagnostic Trouble Code (DTC) Detecting Criteria.>
P0171	System too Lean (Bank 1)	<Ref. to GD(H4SO)-63, DTC P0171 SYSTEM TOO LEAN (BANK 1), Diagnostic Trouble Code (DTC) Detecting Criteria.>
P0172	System too Rich (Bank 1)	<Ref. to GD(H4SO)-65, DTC P0172 SYSTEM TOO RICH (BANK 1), Diagnostic Trouble Code (DTC) Detecting Criteria.>
P0181	Fuel Temperature Sensor "A" Circuit Range/Performance	<Ref. to GD(H4SO)-67, DTC P0181 FUEL TEMPERATURE SENSOR "A" CIRCUIT RANGE/PERFORMANCE, Diagnostic Trouble Code (DTC) Detecting Criteria.>
P0182	Fuel Temperature Sensor "A" Circuit Low Input	<Ref. to GD(H4SO)-70, DTC P0182 FUEL TEMPERATURE SENSOR "A" CIRCUIT LOW INPUT, Diagnostic Trouble Code (DTC) Detecting Criteria.>
P0183	Fuel Temperature Sensor "A" Circuit High Input	<Ref. to GD(H4SO)-71, DTC P0183 FUEL TEMPERATURE SENSOR "A" CIRCUIT HIGH INPUT, Diagnostic Trouble Code (DTC) Detecting Criteria.>
P0196	Engine Oil Temperature Sensor Circuit Range/Performance	<Ref. to GD(H4SO)-73, DTC P0196 ENGINE OIL TEMPERATURE SENSOR CIRCUIT RANGE/PERFORMANCE, Diagnostic Trouble Code (DTC) Detecting Criteria.>
P0197	Engine Oil Temperature Sensor Low	<Ref. to GD(H4SO)-74, DTC P0197 ENGINE OIL TEMPERATURE SENSOR CIRCUIT LOW, Diagnostic Trouble Code (DTC) Detecting Criteria.>

## List of Diagnostic Trouble Code (DTC)

### GENERAL DESCRIPTION

DTC	Item	Index
P0198	Engine Oil Temperature Sensor High	<Ref. to GD(H4SO)-75, DTC P0198 ENGINE OIL TEMPERATURE SENSOR CIRCUIT HIGH, Diagnostic Trouble Code (DTC) Detecting Criteria.>
P0222	Throttle/Pedal Position Sensor/Switch "B" Circuit Low Input	<Ref. to GD(H4SO)-76, DTC P0222 THROTTLE/PEDAL POSITION SENSOR/SWITCH "B" CIRCUIT LOW INPUT, Diagnostic Trouble Code (DTC) Detecting Criteria.>
P0223	Throttle/Pedal Position Sensor/Switch "B" Circuit High Input	<Ref. to GD(H4SO)-77, DTC P0223 THROTTLE/PEDAL POSITION SENSOR/SWITCH "B" CIRCUIT HIGH INPUT, Diagnostic Trouble Code (DTC) Detecting Criteria.>
P0301	Cylinder 1 misfire detected	<Ref. to GD(H4SO)-78, DTC P0301 CYLINDER 1 MISFIRE DETECTED, Diagnostic Trouble Code (DTC) Detecting Criteria.>
P0302	Cylinder 2 misfire detected	<Ref. to GD(H4SO)-83, DTC P0302 CYLINDER 2 MISFIRE DETECTED, Diagnostic Trouble Code (DTC) Detecting Criteria.>
P0303	Cylinder 3 misfire detected	<Ref. to GD(H4SO)-83, DTC P0303 CYLINDER 3 MISFIRE DETECTED, Diagnostic Trouble Code (DTC) Detecting Criteria.>
P0304	Cylinder 4 misfire detected	<Ref. to GD(H4SO)-83, DTC P0304 CYLINDER 4 MISFIRE DETECTED, Diagnostic Trouble Code (DTC) Detecting Criteria.>
P0327	Knock Sensor 1 Circuit Low Input (Bank 1 or Single Sensor)	<Ref. to GD(H4SO)-84, DTC P0327 KNOCK SENSOR 1 CIRCUIT LOW INPUT (BANK 1 OR SINGLE SENSOR), Diagnostic Trouble Code (DTC) Detecting Criteria.>
P0328	Knock Sensor 1 Circuit High Input (Bank 1 or Single Sensor)	<Ref. to GD(H4SO)-86, DTC P0328 KNOCK SENSOR 1 CIRCUIT HIGH INPUT (BANK 1 OR SINGLE SENSOR), Diagnostic Trouble Code (DTC) Detecting Criteria.>
P0335	Crankshaft Position Sensor "A" Circuit	<Ref. to GD(H4SO)-88, DTC P0335 CRANKSHAFT POSITION SENSOR "A" CIRCUIT, Diagnostic Trouble Code (DTC) Detecting Criteria.>
P0336	Crankshaft Position Sensor "A" Circuit Range/Performance	<Ref. to GD(H4SO)-90, DTC P0336 CRANKSHAFT POSITION SENSOR "A" CIRCUIT RANGE/PERFORMANCE, Diagnostic Trouble Code (DTC) Detecting Criteria.>
P0340	Camshaft Position Sensor "A" Circuit (Bank 1 or Single Sensor)	<Ref. to GD(H4SO)-92, DTC P0340 CAMSHAFT POSITION SENSOR "A" CIRCUIT (BANK 1 OR SINGLE SENSOR), Diagnostic Trouble Code (DTC) Detecting Criteria.>
P0341	Camshaft Position Sensor "A" Circuit Range/Performance (Bank 1 or Single Sensor)	<Ref. to GD(H4SO)-94, DTC P0341 CAMSHAFT POSITION SENSOR "A" CIRCUIT RANGE/PERFORMANCE (BANK 1 OR SINGLE SENSOR), Diagnostic Trouble Code (DTC) Detecting Criteria.>
P0400	Exhaust Gas Recirculation Flow	<Ref. to GD(H4SO)-96, DTC P0400 EXHAUST GAS RECIRCULATION FLOW, Diagnostic Trouble Code (DTC) Detecting Criteria.>
P0420	Catalyst System Efficiency Below Threshold (Bank 1)	<Ref. to GD(H4SO)-99, DTC P0420 CATALYST SYSTEM EFFICIENCY BELOW THRESHOLD (BANK 1), Diagnostic Trouble Code (DTC) Detecting Criteria.>
P0442	Evaporative Emission Control System Leak Detected (small leak)	<Ref. to GD(H4SO)-101, DTC P0442 EVAPORATIVE EMISSION CONTROL SYSTEM LEAK DETECTED (SMALL LEAK), Diagnostic Trouble Code (DTC) Detecting Criteria.>
P0447	Evaporative Emission Control System Vent Control Circuit Open	<Ref. to GD(H4SO)-116, DTC P0447 EVAPORATIVE EMISSION CONTROL SYSTEM VENT CONTROL CIRCUIT OPEN, Diagnostic Trouble Code (DTC) Detecting Criteria.>
P0448	Evaporative Emission Control System Vent Control Circuit Shorted	<Ref. to GD(H4SO)-118, DTC P0448 EVAPORATIVE EMISSION CONTROL SYSTEM VENT CONTROL CIRCUIT SHORTED, Diagnostic Trouble Code (DTC) Detecting Criteria.>
P0451	Evaporative Emission Control System Pressure Sensor Range/Performance	<Ref. to GD(H4SO)-120, DTC P0451 EVAPORATIVE EMISSION CONTROL SYSTEM PRESSURE SENSOR RANGE/PERFORMANCE, Diagnostic Trouble Code (DTC) Detecting Criteria.>
P0452	Evaporative Emission Control System Pressure Sensor Low Input	<Ref. to GD(H4SO)-122, DTC P0452 EVAPORATIVE EMISSION CONTROL SYSTEM PRESSURE SENSOR LOW INPUT, Diagnostic Trouble Code (DTC) Detecting Criteria.>
P0453	Evaporative Emission Control System Pressure Sensor High Input	<Ref. to GD(H4SO)-124, DTC P0453 EVAPORATIVE EMISSION CONTROL SYSTEM PRESSURE SENSOR HIGH INPUT, Diagnostic Trouble Code (DTC) Detecting Criteria.>

# List of Diagnostic Trouble Code (DTC)

GENERAL DESCRIPTION

DTC	Item	Index
P0456	Evaporative Emission Control System Leak Detected (very small leak)	<Ref. to GD(H4SO)-125, DTC P0456 EVAPORATIVE EMISSION CONTROL SYSTEM LEAK DETECTED (VERY SMALL LEAK), Diagnostic Trouble Code (DTC) Detecting Criteria.>
P0457	Evaporative Emission Control System Leak Detected (fuel cap loose/off)	<Ref. to GD(H4SO)-125, DTC P0457 EVAPORATIVE EMISSION CONTROL SYSTEM LEAK DETECTED (FUEL CAP LOOSE/OFF), Diagnostic Trouble Code (DTC) Detecting Criteria.>
P0458	Evaporative Emission Control System Purge Control Valve Circuit Low	<Ref. to GD(H4SO)-126, DTC P0458 EVAPORATIVE EMISSION CONTROL SYSTEM PURGE CONTROL VALVE CIRCUIT LOW, Diagnostic Trouble Code (DTC) Detecting Criteria.>
P0459	Evaporative Emission Control System Purge Control Valve Circuit High	<Ref. to GD(H4SO)-127, DTC P0459 EVAPORATIVE EMISSION CONTROL SYSTEM PURGE CONTROL VALVE CIRCUIT HIGH, Diagnostic Trouble Code (DTC) Detecting Criteria.>
P0461	Fuel Level Sensor Circuit Range/Performance	<Ref. to GD(H4SO)-129, DTC P0461 FUEL LEVEL SENSOR CIRCUIT RANGE/PERFORMANCE, Diagnostic Trouble Code (DTC) Detecting Criteria.>
P0462	Fuel Level Sensor Circuit Low Input	<Ref. to GD(H4SO)-131, DTC P0462 FUEL LEVEL SENSOR CIRCUIT LOW INPUT, Diagnostic Trouble Code (DTC) Detecting Criteria.>
P0463	Fuel Level Sensor Circuit High Input	<Ref. to GD(H4SO)-133, DTC P0463 FUEL LEVEL SENSOR CIRCUIT HIGH INPUT, Diagnostic Trouble Code (DTC) Detecting Criteria.>
P0464	Fuel Level Sensor Circuit Intermittent	<Ref. to GD(H4SO)-135, DTC P0464 FUEL LEVEL SENSOR CIRCUIT INTERMITTENT, Diagnostic Trouble Code (DTC) Detecting Criteria.>
P0483	Cooling Fan Rationality Check	<Ref. to GD(H4SO)-138, DTC P0483 COOLING FAN RATIONALITY CHECK, Diagnostic Trouble Code (DTC) Detecting Criteria.>
P0502	Vehicle Speed Sensor Circuit Low Input	<Ref. to GD(H4SO)-139, DTC P0502 VEHICLE SPEED SENSOR CIRCUIT LOW INPUT, Diagnostic Trouble Code (DTC) Detecting Criteria.>
P0503	Vehicle Speed Sensor Intermittent/Erratic/High	<Ref. to GD(H4SO)-140, DTC P0503 VEHICLE SPEED SENSOR INTERMITTENT/ERRATIC/HIGH, Diagnostic Trouble Code (DTC) Detecting Criteria.>
P0506	Idle Control System RPM Lower Than Expected	<Ref. to GD(H4SO)-141, DTC P0506 IDLE CONTROL SYSTEM RPM LOWER THAN EXPECTED, Diagnostic Trouble Code (DTC) Detecting Criteria.>
P0507	Idle Control System RPM Higher Than Expected	<Ref. to GD(H4SO)-142, DTC P0507 IDLE CONTROL SYSTEM RPM HIGHER THAN EXPECTED, Diagnostic Trouble Code (DTC) Detecting Criteria.>
P0512	Starter Request Circuit	<Ref. to GD(H4SO)-143, DTC P0512 STARTER REQUEST CIRCUIT, Diagnostic Trouble Code (DTC) Detecting Criteria.>
P0513	Incorrect Immobilizer Key	<Ref. to GD(H4SO)-144, DTC P0513 INCORRECT IMMOBILIZER KEY, Diagnostic Trouble Code (DTC) Detecting Criteria.>
P0519	Idle Control System Malfunction (Fail-Safe)	<Ref. to GD(H4SO)-145, DTC P0519 IDLE CONTROL SYSTEM MALFUNCTION (FAIL-SAFE), Diagnostic Trouble Code (DTC) Detecting Criteria.>
P0600	Serial Communication Link	<Ref. to GD(H4SO)-146, DTC P0600 SERIAL COMMUNICATION LINK, Diagnostic Trouble Code (DTC) Detecting Criteria.>
P0604	Internal Control Module Random Access Memory (RAM) Error	<Ref. to GD(H4SO)-147, DTC P0604 INTERNAL CONTROL MODULE RANDOM ACCESS MEMORY (RAM) ERROR, Diagnostic Trouble Code (DTC) Detecting Criteria.>
P0605	Internal Control Module Read Only Memory (ROM) Error	<Ref. to GD(H4SO)-148, DTC P0605 INTERNAL CONTROL MODULE READ ONLY MEMORY (ROM) ERROR, Diagnostic Trouble Code (DTC) Detecting Criteria.>
P0607	Control Module Performance	<Ref. to GD(H4SO)-149, DTC P0607 CONTROL MODULE PERFORMANCE, Diagnostic Trouble Code (DTC) Detecting Criteria.>
P0638	Throttle Actuator Control Range/Performance (Bank 1)	<Ref. to GD(H4SO)-151, DTC P0638 THROTTLE ACTUATOR CONTROL RANGE/PERFORMANCE (BANK 1), Diagnostic Trouble Code (DTC) Detecting Criteria.>
P0691	Cooling Fan 1 Control Circuit Low	<Ref. to GD(H4SO)-153, DTC P0691 COOLING FAN 1 CONTROL CIRCUIT LOW, Diagnostic Trouble Code (DTC) Detecting Criteria.>
P0692	Cooling Fan 1 Control Circuit High	<Ref. to GD(H4SO)-154, DTC P0692 COOLING FAN 1 CONTROL CIRCUIT HIGH, Diagnostic Trouble Code (DTC) Detecting Criteria.>

## List of Diagnostic Trouble Code (DTC)

### GENERAL DESCRIPTION

DTC	Item	Index
P0700	AT MIL Light up Request	<Ref. to GD(H4SO)-155, DTC P0700 TRANSMISSION CONTROL SYSTEM (MIL REQUEST), Diagnostic Trouble Code (DTC) Detecting Criteria.>
P0851	Neutral Switch Input Circuit Low (AT model)	<Ref. to GD(H4SO)-156, DTC P0851 NEUTRAL SWITCH INPUT CIRCUIT LOW (AT MODEL), Diagnostic Trouble Code (DTC) Detecting Criteria.>
P0851	Neutral Switch Input Circuit Low (MT model)	<Ref. to GD(H4SO)-157, DTC P0851 NEUTRAL SWITCH INPUT CIRCUIT LOW (MT MODEL), Diagnostic Trouble Code (DTC) Detecting Criteria.>
P0852	Neutral Switch Input Circuit High (AT model)	<Ref. to GD(H4SO)-158, DTC P0852 NEUTRAL SWITCH INPUT CIRCUIT HIGH (AT MODEL), Diagnostic Trouble Code (DTC) Detecting Criteria.>
P0852	Neutral Switch Input Circuit High (MT model)	<Ref. to GD(H4SO)-159, DTC P0852 NEUTRAL SWITCH INPUT CIRCUIT HIGH (MT MODEL), Diagnostic Trouble Code (DTC) Detecting Criteria.>
P1152	O <sub>2</sub> Sensor Circuit Range/Performance (Low) (Bank 1 Sensor 1)	<Ref. to GD(H4SO)-160, DTC P1152 O <sub>2</sub> SENSOR CIRCUIT RANGE/PERFORMANCE (LOW) (BANK1 SENSOR1), Diagnostic Trouble Code (DTC) Detecting Criteria.>
P1153	O <sub>2</sub> Sensor Circuit Range/Performance (High) (Bank 1 Sensor 1)	<Ref. to GD(H4SO)-162, DTC P1153 O <sub>2</sub> SENSOR CIRCUIT RANGE/PERFORMANCE (HIGH) (BANK1 SENSOR1), Diagnostic Trouble Code (DTC) Detecting Criteria.>
P1160	Return Spring Failure	<Ref. to GD(H4SO)-164, DTC P1160 RETURN SPRING FAILURE, Diagnostic Trouble Code (DTC) Detecting Criteria.>
P1400	Fuel Tank Pressure Control Solenoid Valve Circuit Low	<Ref. to GD(H4SO)-165, DTC P1400 FUEL TANK PRESSURE CONTROL SOLENOID VALVE CIRCUIT LOW, Diagnostic Trouble Code (DTC) Detecting Criteria.>
P1420	Fuel Tank Pressure Control Sol. Valve Circuit High	<Ref. to GD(H4SO)-167, DTC P1420 FUEL TANK PRESSURE CONTROL SOL. VALVE CIRCUIT HIGH, Diagnostic Trouble Code (DTC) Detecting Criteria.>
P1443	Vent Control Solenoid Valve Function Problem	<Ref. to GD(H4SO)-168, DTC P1443 VENT CONTROL SOLENOID VALVE FUNCTION PROBLEM, Diagnostic Trouble Code (DTC) Detecting Criteria.>
P1491	Positive Crankcase Ventilation (Blow-by) Function Problem	<Ref. to GD(H4SO)-170, DTC P1491 POSITIVE CRANKCASE VENTILATION (BLOW-BY) FUNCTION PROBLEM, Diagnostic Trouble Code (DTC) Detecting Criteria.>
P1492	EGR Solenoid Valve Signal #1 Circuit Malfunction (Low Input)	<Ref. to GD(H4SO)-172, DTC P1492 EGR SOLENOID VALVE SIGNAL #1 CIRCUIT MALFUNCTION (LOW INPUT), Diagnostic Trouble Code (DTC) Detecting Criteria.>
P1493	EGR Solenoid Valve Signal #1 Circuit Malfunction (High Input)	<Ref. to GD(H4SO)-174, DTC P1493 EGR SOLENOID VALVE SIGNAL #1 CIRCUIT MALFUNCTION (HIGH INPUT), Diagnostic Trouble Code (DTC) Detecting Criteria.>
P1494	EGR Solenoid Valve Signal #2 Circuit Malfunction (Low Input)	<Ref. to GD(H4SO)-175, DTC P1494 EGR SOLENOID VALVE SIGNAL #2 CIRCUIT MALFUNCTION (LOW INPUT), Diagnostic Trouble Code (DTC) Detecting Criteria.>
P1495	EGR Solenoid Valve Signal #2 Circuit Malfunction (High Input)	<Ref. to GD(H4SO)-175, DTC P1495 EGR SOLENOID VALVE SIGNAL #2 CIRCUIT MALFUNCTION (HIGH INPUT), Diagnostic Trouble Code (DTC) Detecting Criteria.>
P1496	EGR Solenoid Valve Signal #3 Circuit Malfunction (Low Input)	<Ref. to GD(H4SO)-175, DTC P1496 EGR SOLENOID VALVE SIGNAL #3 CIRCUIT MALFUNCTION (LOW INPUT), Diagnostic Trouble Code (DTC) Detecting Criteria.>
P1497	EGR Solenoid Valve Signal #3 Circuit Malfunction (High Input)	<Ref. to GD(H4SO)-175, DTC P1497 EGR SOLENOID VALVE SIGNAL #3 CIRCUIT MALFUNCTION (HIGH INPUT), Diagnostic Trouble Code (DTC) Detecting Criteria.>
P1498	EGR Solenoid Valve Signal #4 Circuit Malfunction (Low Input)	<Ref. to GD(H4SO)-176, DTC P1498 EGR SOLENOID VALVE SIGNAL #4 CIRCUIT MALFUNCTION (LOW INPUT), Diagnostic Trouble Code (DTC) Detecting Criteria.>
P1499	EGR Solenoid Valve Signal #4 Circuit Malfunction (High Input)	<Ref. to GD(H4SO)-176, DTC P1499 EGR SOLENOID VALVE SIGNAL #4 CIRCUIT MALFUNCTION (HIGH INPUT), Diagnostic Trouble Code (DTC) Detecting Criteria.>
P1518	Starter Switch Circuit Low Input	<Ref. to GD(H4SO)-176, DTC P1518 STARTER SWITCH CIRCUIT LOW INPUT, Diagnostic Trouble Code (DTC) Detecting Criteria.>
P1560	Back-Up Voltage Circuit Malfunction	<Ref. to GD(H4SO)-177, DTC P1560 BACK-UP VOLTAGE CIRCUIT MALFUNCTION, Diagnostic Trouble Code (DTC) Detecting Criteria.>

# List of Diagnostic Trouble Code (DTC)

GENERAL DESCRIPTION

DTC	Item	Index
P1570	Antenna	<Ref. to GD(H4SO)-178, DTC P1570 ANTENNA, Diagnostic Trouble Code (DTC) Detecting Criteria.>
P1571	Reference Code Incompatibility	<Ref. to GD(H4SO)-178, DTC P1571 REFERENCE CODE INCOMPATIBILITY, Diagnostic Trouble Code (DTC) Detecting Criteria.>
P1572	IMM Circuit Failure (Except Antenna Circuit)	<Ref. to GD(H4SO)-178, DTC P1572 IMM CIRCUIT FAILURE (EXCEPT ANTENNA CIRCUIT), Diagnostic Trouble Code (DTC) Detecting Criteria.>
P1574	Key Communication Failure	<Ref. to GD(H4SO)-178, DTC P1574 KEY COMMUNICATION FAILURE, Diagnostic Trouble Code (DTC) Detecting Criteria.>
P1576	EGI Control Module EEPROM	<Ref. to GD(H4SO)-178, DTC P1576 EGI CONTROL MODULE EEPROM, Diagnostic Trouble Code (DTC) Detecting Criteria.>
P1577	IMM Control Module EEPROM	<Ref. to GD(H4SO)-178, DTC P1577 IMM CONTROL MODULE EEPROM, Diagnostic Trouble Code (DTC) Detecting Criteria.>
P2096	Post Catalyst Fuel Trim System Too Lean Bank 1	<Ref. to GD(H4SO)-179, DTC P2096 POST CATALYST FUEL TRIM SYSTEM TOO LEAN BANK 1, Diagnostic Trouble Code (DTC) Detecting Criteria.>
P2097	Post Catalyst Fuel Trim System Too Rich Bank 1	<Ref. to GD(H4SO)-180, DTC P2097 POST CATALYST FUEL TRIM SYSTEM TOO RICH BANK 1, Diagnostic Trouble Code (DTC) Detecting Criteria.>
P2101	Throttle Actuator Control Motor Circuit Range/Performance	<Ref. to GD(H4SO)-182, DTC P2101 THROTTLE ACTUATOR CONTROL MOTOR CIRCUIT RANGE/PERFORMANCE, Diagnostic Trouble Code (DTC) Detecting Criteria.>
P2102	Throttle Actuator Control Motor Circuit Low	<Ref. to GD(H4SO)-184, DTC P2102 THROTTLE ACTUATOR CONTROL MOTOR CIRCUIT LOW, Diagnostic Trouble Code (DTC) Detecting Criteria.>
P2103	Throttle Actuator Control Motor Circuit High	<Ref. to GD(H4SO)-185, DTC P2103 THROTTLE ACTUATOR CONTROL MOTOR CIRCUIT HIGH, Diagnostic Trouble Code (DTC) Detecting Criteria.>
P2109	Throttle/Pedal Position Sensor A Minimum Stop Performance	<Ref. to GD(H4SO)-187, DTC P2109 THROTTLE ANGLE SENSOR CLOSED POSITION ERROR, Diagnostic Trouble Code (DTC) Detecting Criteria.>
P2122	Throttle/Pedal Position Sensor/Switch "D" Circuit Low Input	<Ref. to GD(H4SO)-188, DTC P2122 THROTTLE/PEDAL POSITION SENSOR/SWITCH "D" CIRCUIT LOW INPUT, Diagnostic Trouble Code (DTC) Detecting Criteria.>
P2123	Throttle/Pedal Position Sensor/Switch "D" Circuit High Input	<Ref. to GD(H4SO)-189, DTC P2123 THROTTLE/PEDAL POSITION SENSOR/SWITCH "D" CIRCUIT HIGH INPUT, Diagnostic Trouble Code (DTC) Detecting Criteria.>
P2127	Throttle/Pedal Position Sensor/Switch "E" Circuit Low Input	<Ref. to GD(H4SO)-191, DTC P2127 THROTTLE/PEDAL POSITION SENSOR/SWITCH "E" CIRCUIT LOW INPUT, Diagnostic Trouble Code (DTC) Detecting Criteria.>
P2128	Throttle/Pedal Position Sensor/Switch "E" Circuit High Input	<Ref. to GD(H4SO)-192, DTC P2128 THROTTLE/PEDAL POSITION SENSOR/SWITCH "E" CIRCUIT HIGH INPUT, Diagnostic Trouble Code (DTC) Detecting Criteria.>
P2135	Throttle/Pedal Position Sensor/Switch "A"/"B" Voltage Rationality	<Ref. to GD(H4SO)-193, DTC P2135 THROTTLE/PEDAL POSITION SENSOR/SWITCH "A" / "B" VOLTAGE RATIONALITY, Diagnostic Trouble Code (DTC) Detecting Criteria.>
P2138	Throttle/Pedal Position Sensor/Switch "D"/"E" Voltage Rationality	<Ref. to GD(H4SO)-195, DTC P2138 THROTTLE/PEDAL POSITION SENSOR/SWITCH "D" / "E" VOLTAGE RATIONALITY, Diagnostic Trouble Code (DTC) Detecting Criteria.>
P2227	Atmospheric Pressure Sensor Circuit Range/Performance	<Ref. to GD(H4SO)-197, DTC P2227 BAROMETRIC PRESSURE TOO LOW, Diagnostic Trouble Code (DTC) Detecting Criteria.>
P2228	Atmospheric Pressure Sensor Circuit Malfunction (Low Input)	<Ref. to GD(H4SO)-198, DTC P2228 ATMOSPHERIC PRESSURE SENSOR CIRCUIT MALFUNCTION (LOW INPUT), Diagnostic Trouble Code (DTC) Detecting Criteria.>
P2229	Atmospheric Pressure Sensor Circuit Malfunction (High Input)	<Ref. to GD(H4SO)-199, DTC P2229 ATMOSPHERIC PRESSURE SENSOR CIRCUIT MALFUNCTION (HIGH INPUT), Diagnostic Trouble Code (DTC) Detecting Criteria.>

# Diagnostic Trouble Code (DTC) Detecting Criteria

GENERAL DESCRIPTION

---

## 2. Diagnostic Trouble Code (DTC) Detecting Criteria

### A: DTC P0026 INTAKE VALVE CONTROL SOLENOID CIRCUIT RANGE/PERFORMANCE (BANK 1)

#### 1. OUTLINE OF DIAGNOSIS

Detect NG from Low NG or High NG.

Variable valve lift diagnosis oil pressure switch is attached for diagnosis, ON or OFF of variable valve lift diagnosis oil pressure switch shows whether intake valve is in High mode (increasing the lift amount) or Low mode (decreasing the lift amount).

- **Normal condition**

Oil switching solenoid valve duty	Intake valve	Variable valve lift diagnosis oil pressure switch
Large	High mode	ON
Small	Low mode	OFF

- **Low NG**

Judge Low NG when variable valve lift diagnosis oil pressure switch remains OFF though the intake valve is being shifted to High mode (Oil switching solenoid valve duty: large).

- **High NG**

Judge High NG when variable valve lift diagnosis oil pressure switch remains ON though the intake valve is being shifted to Low mode (Oil switching solenoid valve duty: small).



# Diagnostic Trouble Code (DTC) Detecting Criteria

GENERAL DESCRIPTION

## 2. COMPONENT DESCRIPTION

Variable valve lift system optimizes the lift amount of intake valve with switching low lift cam and high lift cam depending on engine speed. Variable valve system changes the lift amount of intake valve with duty controlling oil switching solenoid valve.

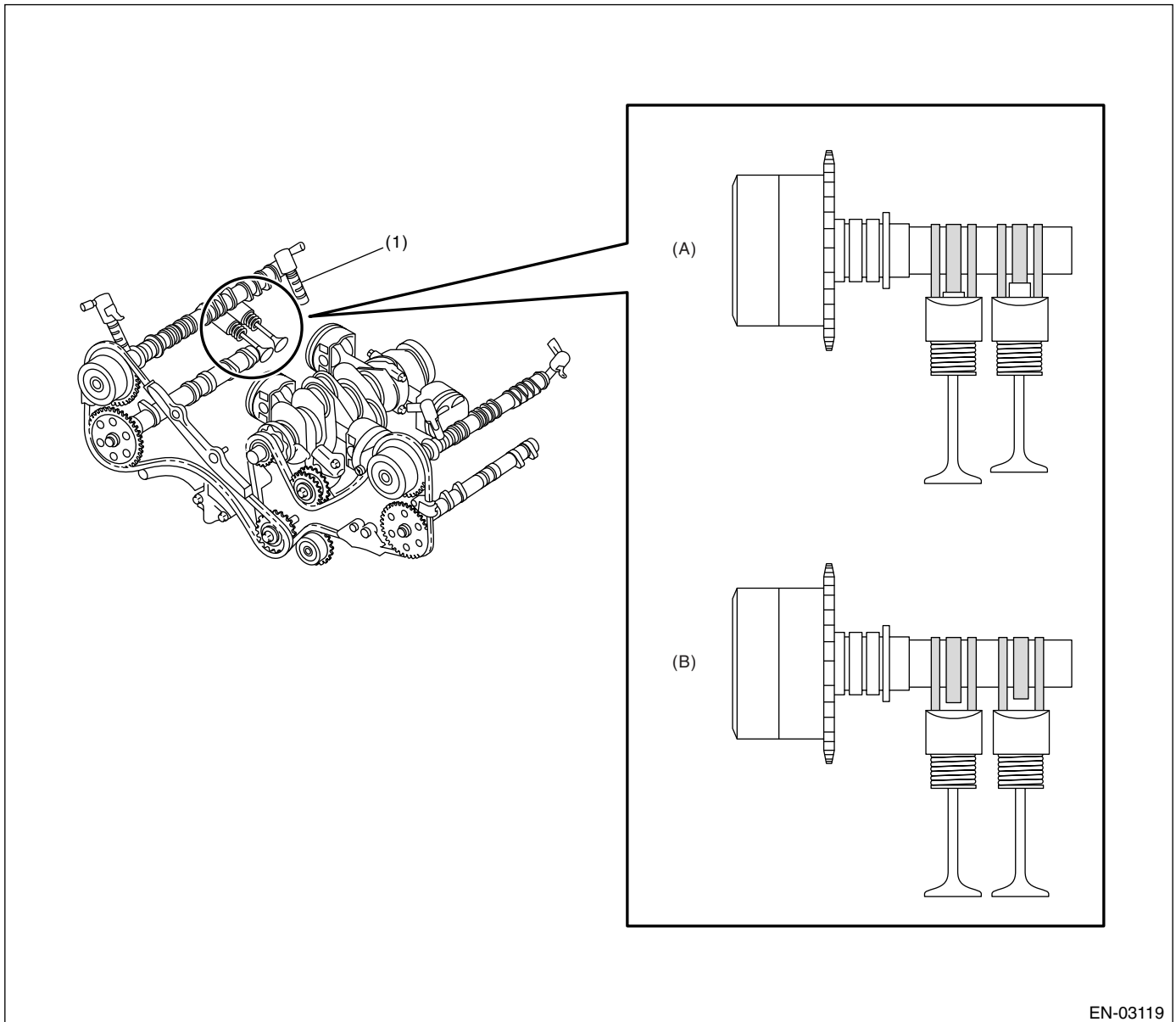

EN-03119

(1) Oil switching solenoid valve

(A) Engine low speed

(B) Engine high speed

## 3. ENABLE CONDITION

Secondary Parameters	Enable Conditions
Battery voltage	$\geq 10.9$ V
After engine starting	$\geq 6$ sec.
Engine oil temperature	$\geq 15^{\circ}\text{C}$ (59°F)
Variable Valve lift control	In operation

## 4. GENERAL DRIVING CYCLE

Perform the diagnosis continuously after 6 seconds from engine starting with controlling of variable valve lift.

# Diagnostic Trouble Code (DTC) Detecting Criteria

## GENERAL DESCRIPTION

---

### 5. DIAGNOSTIC METHOD

#### • Abnormality Judgment

Judge NG when the continuous time of completing the malfunction criteria below becomes more than the specified time.

#### Judgment Value

Malfunction Criteria	Threshold Value
Low NG Duty ratio Variable valve lift diagnosis oil pressure switch	≥ 62% OFF
High NG Duty ratio Variable valve lift diagnosis oil pressure switch	< 33% ON

#### Time needed for diagnosis:

0.784 seconds (Low side)

3.0 seconds (High side)

**Malfunction Indicator Light Illumination:** Illuminates as soon as malfunction occurs.

#### • Normality Judgment

Judge OK and clear NG when the continuous time of completing malfunction criteria becomes more than 3 seconds.

#### Judgment Value

Malfunction Criteria	Threshold Value
Low OK Duty ratio Variable valve lift diagnosis oil pressure switch	≥ 62% ON
High OK Duty ratio Variable valve lift diagnosis oil pressure switch	< 33% OFF

### 6. DTC CLEAR CONDITION

- When the OK idling cycle was completed 40 times in a row
- When "Clear Memory" was performed

### 7. MALFUNCTION INDICATOR LIGHT CLEAR CONDITION

- When the OK cycle was completed 3 times in a row
- When "Clear Memory" was performed

### 8. FAIL SAFE

None

### 9. ECM OPERATION AT DTC SETTING

Memorize the freeze frame data. (For test mode \$02)

## **B: DTC P0028 INTAKE VALVE CONTROL SOLENOID CIRCUIT RANGE/PERFORMANCE (BANK 2)**

#### NOTE:

For the diagnostic procedure, refer to DTC P0026. <Ref. to GD(H4SO)-8, DTC P0026 INTAKE VALVE CONTROL SOLENOID CIRCUIT RANGE/PERFORMANCE (BANK 1), Diagnostic Trouble Code (DTC) Detecting Criteria.>

# Diagnostic Trouble Code (DTC) Detecting Criteria

GENERAL DESCRIPTION

## C: DTC P0030 HO2S HEATER CONTROL CIRCUIT (BANK 1 SENSOR 1)

### 1. OUTLINE OF DIAGNOSIS

Detect the malfunction of front oxygen (A/F) sensor heater.

Judge NG when impedance of front oxygen (A/F) sensor is larger than the standard value by referring to the engine condition such as fuel shut-off in deceleration, etc.

### 2. COMPONENT DESCRIPTION

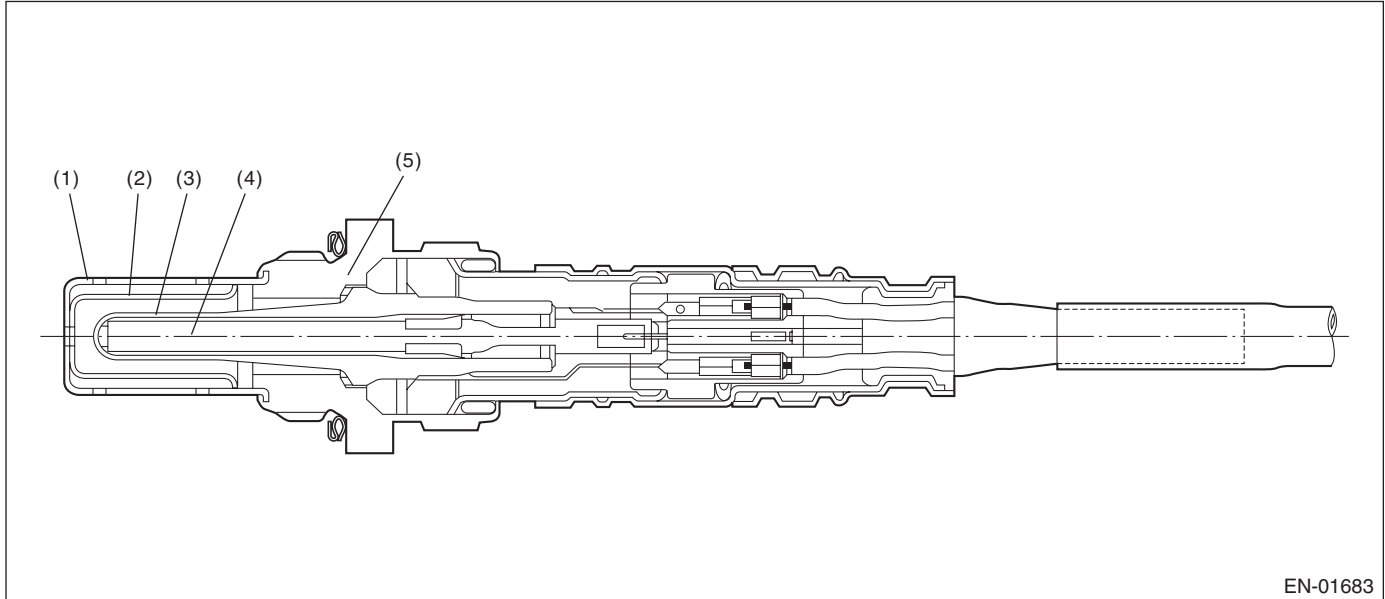

- (1) Element cover (Outer)
- (2) Element cover (Inner)

- (3) Sensor element
- (4) Ceramic heater

- (5) Sensor housing

### 3. ENABLE CONDITION

Secondary Parameters	Enable Conditions
Continuous time which all the following conditions were filled	30 seconds or more
Battery voltage	> 10.9 V
After fuel shut-off	20 seconds or more
Heater current	In operation
Front oxygen (A/F) sensor duty $\geq$ 35%	Experienced

### 4. GENERAL DRIVING CYCLE

Perform diagnosis continuously in 50 seconds after starting engine.

### 5. DIAGNOSTIC METHOD

Judge NG when the continuous time of completing the malfunction criteria below becomes more than the time needed for diagnosis (10 seconds). Judge OK and clear NG when the continuous time of not completing the malfunction criteria below becomes more than the time needed for diagnosis (10 seconds).

#### Judgment Value

Malfunction Criteria	Threshold Value
Impedance of front oxygen (A/F) sensor	> 50 $\Omega$

**Time Needed for Diagnosis:** 10 seconds

**Malfunction Indicator Light Illumination:** Illuminates when malfunction occurs in 2 continuous driving cycles.

# Diagnostic Trouble Code (DTC) Detecting Criteria

## GENERAL DESCRIPTION

### 6. DTC CLEAR CONDITION

- When the OK idling cycle was completed 40 times in a row
- When “Clear Memory” was performed

### 7. MALFUNCTION INDICATOR LIGHT CLEAR CONDITION

- When the OK driving cycle was completed 3 times in a row
- When “Clear Memory” was performed

### 8. FAIL SAFE

- Front oxygen (A/F) sensor main learning correction: Not allowed to calculate
- Front oxygen (A/F) sensor sub learning correction: Do not calculate.
- Purge control: Not allowed to purge

### 9. ECM OPERATION AT DTC SETTING

Memorize the freeze frame data. (For test mode \$02)

## D: DTC P0031 HO2S HEATER CONTROL CIRCUIT LOW (BANK 1 SENSOR 1)

### 1. OUTLINE OF DIAGNOSIS

Detect the open or short circuit of heater.

The heater conducts the duty control. The output terminal voltage at ON becomes 0 V, and the output terminal voltage at OFF becomes battery voltage.

Judge NG when the terminal voltage remains to be Low.

### 2. COMPONENT DESCRIPTION

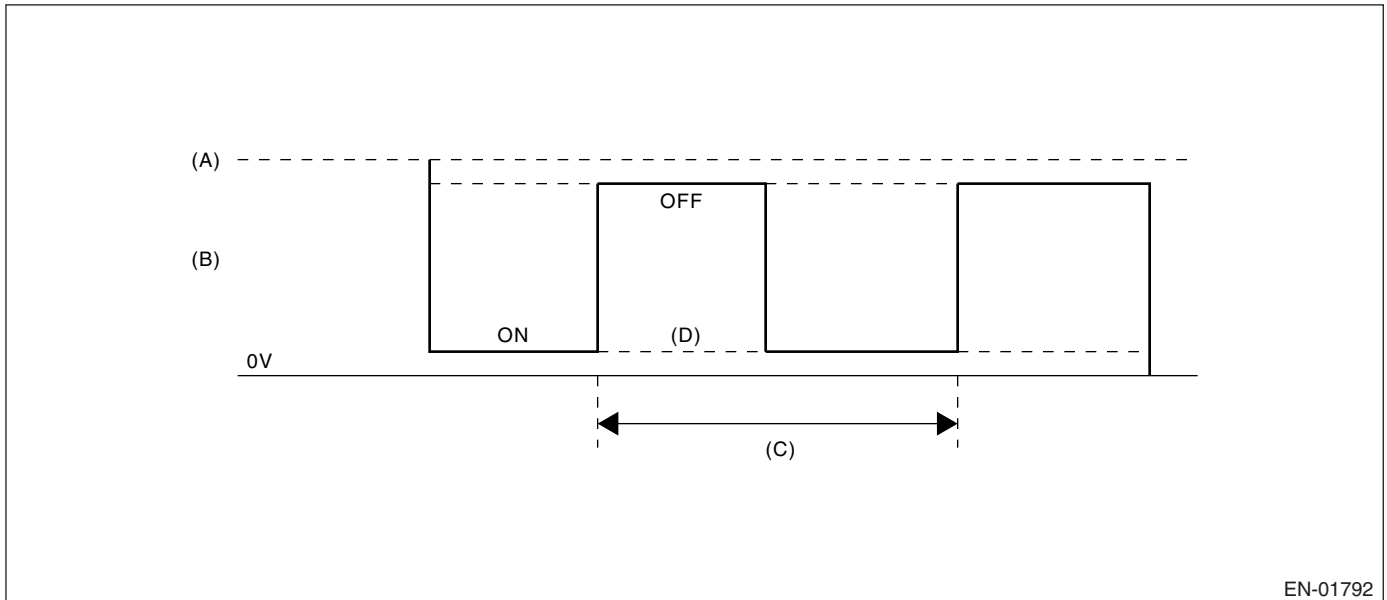

EN-01792

- |   |                                    |
|---|------------------------------------|
| (A) Battery voltage                                 | (C) 128 milliseconds               |
| (B) Front oxygen (A/F) sensor heater output voltage | (D) Low abnormality output voltage |

### 3. ENABLE CONDITION

Secondary Parameters	Enable Conditions
Battery voltage	$\geq 10.9$ V

### 4. GENERAL DRIVING CYCLE

Always perform diagnosis continuously.

# Diagnostic Trouble Code (DTC) Detecting Criteria

GENERAL DESCRIPTION

## 5. DIAGNOSTIC METHOD

### • Abnormality Judgment

Judge NG when the continuous time of completing the malfunction criteria below becomes more than 1 second (8 cycles).

### Judgment Value

Malfunction Criteria	Threshold Value
Output voltage level	Low
Front oxygen (A/F) sensor heater control duty	< 87.5%

**Time Needed for Diagnosis:** 1 second

**Malfunction Indicator Light Illumination:** Illuminates as soon as malfunction occurs.

### • Normality Judgment

Judge OK and clear the NG when all the malfunction criteria below are completed.

### Judgment Value

Malfunction Criteria	Threshold Value
Output voltage level	High

## 6. DTC CLEAR CONDITION

- When the OK idling cycle was completed 40 times in a row
- When "Clear Memory" was performed

## 7. MALFUNCTION INDICATOR LIGHT CLEAR CONDITION

- When the OK driving cycle was completed 3 times in a row
- When "Clear Memory" was performed

## 8. FAIL SAFE

- Front oxygen (A/F) sensor heater control: Not allowed to turn on the heater.
- A/F main learning: Not allowed to calculate the A/F main learning compensation factor.
- A/F sub learning: Not allowed to calculate the A/F sub learning compensation factor.
- Purge control: Not allowed to purge.

## 9. ECM OPERATION AT DTC SETTING

Memorize the freeze frame data. (For test mode \$02)

# Diagnostic Trouble Code (DTC) Detecting Criteria

## GENERAL DESCRIPTION

### E: DTC P0032 HO2S HEATER CONTROL CIRCUIT HIGH (BANK 1 SENSOR 1)

#### 1. OUTLINE OF DIAGNOSIS

Detect the open or short circuit of heater.

The heater conducts the duty control. The output terminal voltage at ON becomes 0 V, and the output terminal voltage at OFF becomes battery voltage.

Judge NG when the terminal voltage remains to be High.

#### 2. COMPONENT DESCRIPTION

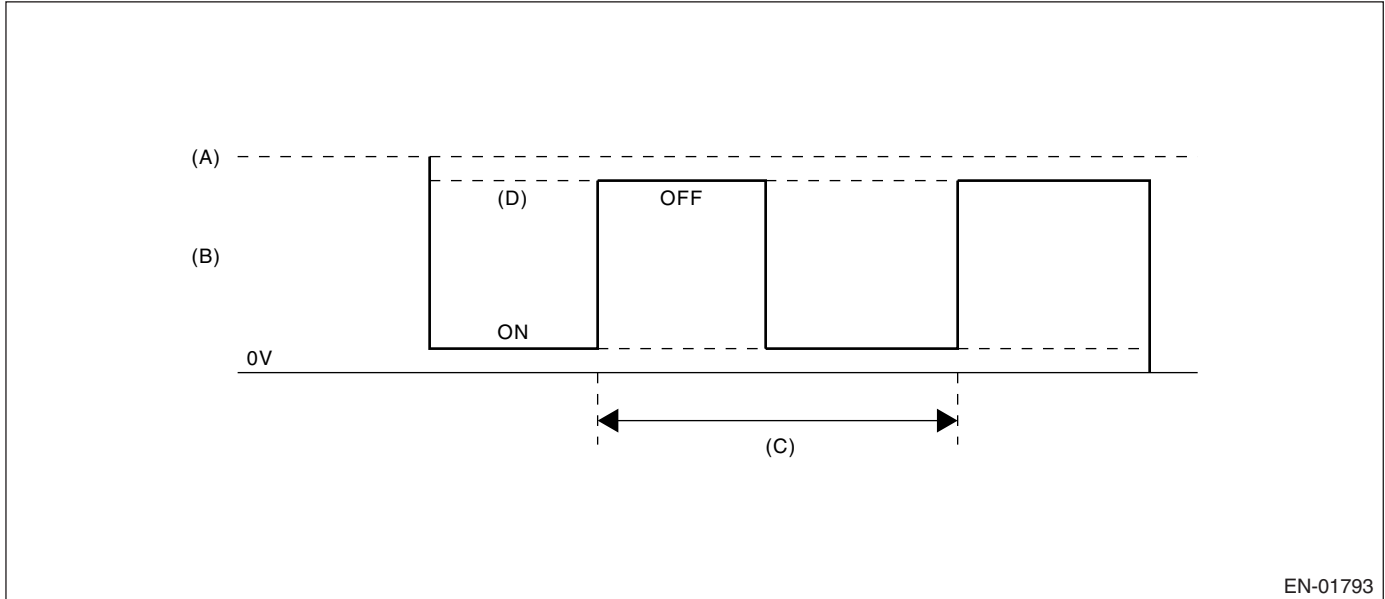

EN-01793

- |   |                                     |
|---|-------------------------------------|
| (A) Battery voltage                                 | (C) 128 milliseconds                |
| (B) Front oxygen (A/F) sensor heater output voltage | (D) High abnormality output voltage |

#### 3. ENABLE CONDITION

Secondary Parameters	Enable Conditions
Battery voltage	$\geq 10.9 \text{ V}$

#### 4. GENERAL DRIVING CYCLE

Always perform diagnosis continuously.

#### 5. DIAGNOSTIC METHOD

##### • Abnormality Judgment

Judge NG when the continuous time of completing the malfunction criteria below becomes 1 second (8 cycles).

##### Judgment Value

Malfunction Criteria	Threshold Value
Output voltage level	High
Front oxygen (A/F) sensor heater control duty	$\geq 12.5\%$

**Time Needed for Diagnosis:** 1 second

**Malfunction Indicator Light Illumination:** Illuminates as soon as malfunction occurs.

# Diagnostic Trouble Code (DTC) Detecting Criteria

GENERAL DESCRIPTION

## • Normality Judgment

Judge OK and clear the NG when all the malfunction criteria below are completed.

### Judgment Value

Malfunction Criteria	Threshold Value
Output voltage level	Low

## 6. DTC CLEAR CONDITION

- When the OK idling cycle was completed 40 times in a row
- When "Clear Memory" was performed

## 7. MALFUNCTION INDICATOR LIGHT CLEAR CONDITION

- When the OK driving cycle was completed 3 times in a row
- When "Clear Memory" was performed

## 8. FAIL SAFE

- Front oxygen (A/F) sensor heater control: Not allowed to turn on the heater.
- A/F main learning: Not allowed to calculate the A/F main learning compensation factor.
- A/F sub learning: Not allowed to calculate the A/F sub learning compensation factor.
- Purge control: Not allowed to purge.

## 9. ECM OPERATION AT DTC SETTING

Memorize the freeze frame data. (For test mode \$02)

# Diagnostic Trouble Code (DTC) Detecting Criteria

## GENERAL DESCRIPTION

### F: DTC P0037 HO2S HEATER CONTROL CIRCUIT LOW (BANK 1 SENSOR 2)

#### 1. OUTLINE OF DIAGNOSIS

Detect open or short circuit of oxygen sensor heater.

Oxygen sensor heater conducted the duty control, and the output terminal voltage at ON is 0 V and the output terminal voltage at OFF is the battery voltage.

Judge NG when the terminal voltage remains to be Low.

#### 2. COMPONENT DESCRIPTION

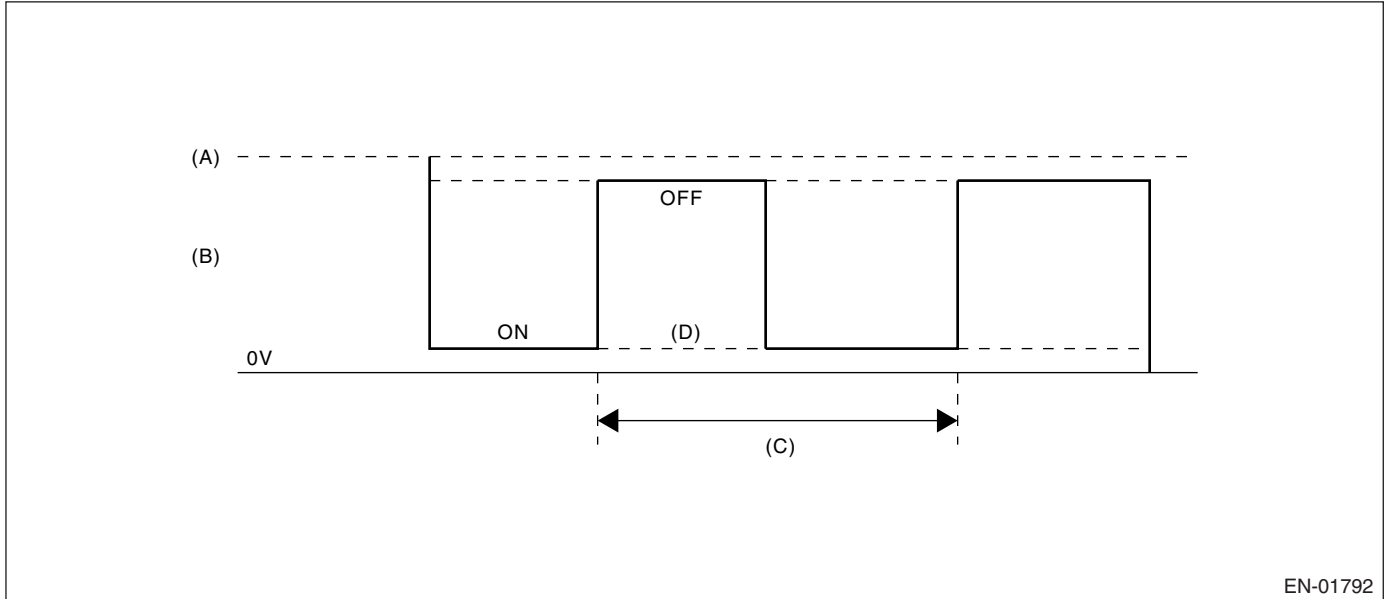

EN-01792

- |   |                               |
|---|-------------------------------|
| (A) Battery voltage                     | (C) 256 milliseconds (cycles) |
| (B) Oxygen sensor heater output voltage | (D) Low malfunction           |

#### 3. ENABLE CONDITION

Secondary Parameters	Enable Conditions
Battery voltage	> 10.9 V
Elapsed time after engine starting	≥ 1 second

#### 4. GENERAL DRIVING CYCLE

Perform the diagnosis continuously after engine starting.

#### 5. DIAGNOSTIC METHOD

##### • Abnormality Judgment

Judge NG when the continuous time of completing all the malfunction criteria below becomes more than 2,560 millisecond (10 cycles).

##### Judgment Value

Malfunction Criteria	Threshold Value
Output voltage level	Low
Oxygen sensor heater control duty	< 75%

**Time Needed for Diagnosis:** 2.56 seconds

**Malfunction Indicator Light Illumination:** Illuminates when malfunction occurs in 2 continuous driving cycles.



# Diagnostic Trouble Code (DTC) Detecting Criteria

GENERAL DESCRIPTION

## • Normality Judgment

Judge OK and clear the NG when all the malfunction criteria below are completed.

### Judgment Value

Malfunction Criteria	Threshold Value
Output voltage level	High

## 6. DTC CLEAR CONDITION

- When the OK idling cycle was completed 40 times in a row
- When "Clear Memory" was performed

## 7. MALFUNCTION INDICATOR LIGHT CLEAR CONDITION

- When the OK driving cycle was completed 3 times in a row
- When "Clear Memory" was performed

## 8. FAIL SAFE

Sub feedback control: Not allowed

## 9. ECM OPERATION AT DTC SETTING

Memorize the freeze frame data. (For test mode \$02)

## G: DTC P0038 HO2S HEATER CONTROL CIRCUIT HIGH (BANK 1 SENSOR 2)

### 1. OUTLINE OF DIAGNOSIS

Detect open or short circuit of oxygen heater.

Oxygen heater conducted the duty control, and the output terminal voltage at ON is 0 V and the output terminal voltage at OFF is the battery voltage.

Judge NG when the terminal voltage remains to be High.

### 2. COMPONENT DESCRIPTION

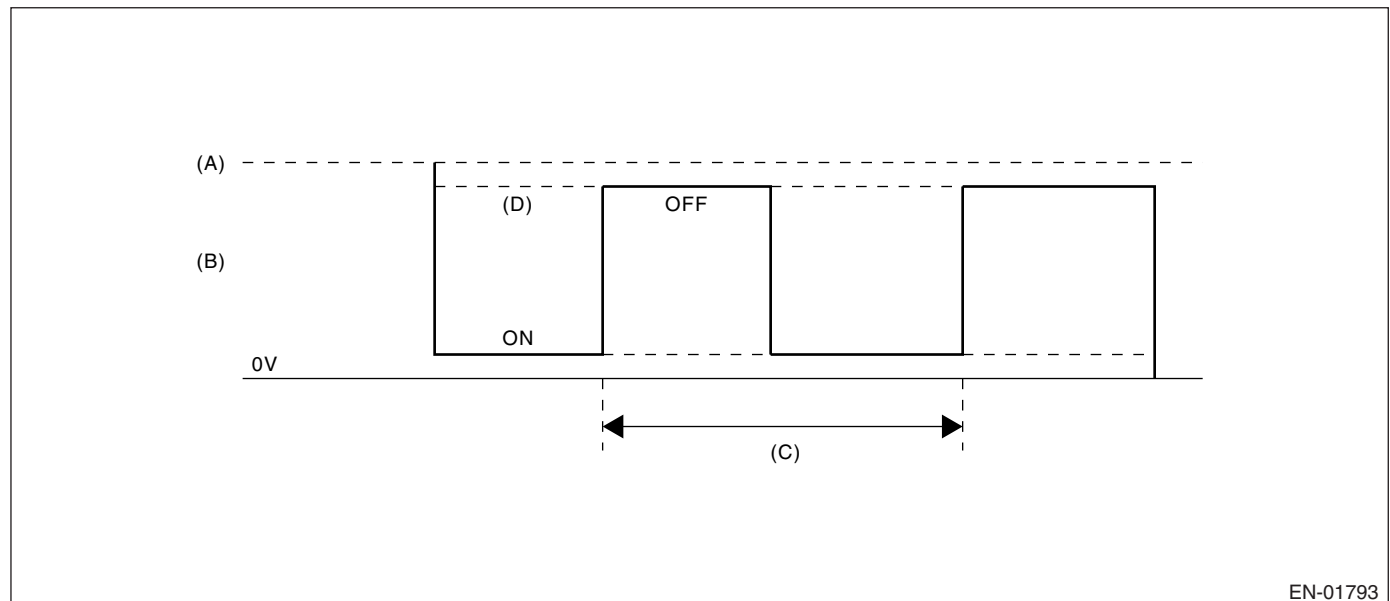

- |   |                               |
|---|-------------------------------|
| (A) Battery voltage                     | (C) 256 milliseconds (cycles) |
| (B) Oxygen sensor heater output voltage | (D) High malfunction          |

# Diagnostic Trouble Code (DTC) Detecting Criteria

## GENERAL DESCRIPTION

---

### 3. ENABLE CONDITION

Secondary Parameters	Enable Conditions
Battery voltage	> 10.9 V
Elapsed time after engine starting	≥ 1 second

### 4. GENERAL DRIVING CYCLE

Perform the diagnosis continuously after engine starting.

### 5. DIAGNOSTIC METHOD

#### • Abnormality Judgment

Judge NG when the continuous time of completing all the malfunction criteria below becomes more than 2,560 milliseconds (10 cycles).

#### Judgment Value

Malfunction Criteria	Threshold Value
Output voltage level	High
Oxygen sensor heater control duty	≥ 20%

**Time Needed for Diagnosis:** 2.56 seconds

**Malfunction Indicator Light Illumination:** Illuminates when malfunction occurs in 2 continuous driving cycles.

#### • Normality Judgment

Judge OK and clear the NG when all the malfunction criteria below are completed.

#### Judgment Value

Malfunction Criteria	Threshold Value
Output voltage level	Low

### 6. DTC CLEAR CONDITION

- When the OK idling cycle was completed 40 times in a row
- When "Clear Memory" was performed

### 7. MALFUNCTION INDICATOR LIGHT CLEAR CONDITION

- When the OK driving cycle was completed 3 times in a row
- When "Clear Memory" was performed

### 8. FAIL SAFE

Sub feedback control: Not allowed

### 9. ECM OPERATION AT DTC SETTING

Memorize the freeze frame data. (For test mode \$02)

## H: DTC P0068 MANIFOLD PRESSURE SENSOR RANGE/PERFORMANCE

### 1. OUTLINE OF DIAGNOSIS

Detect the malfunction of intake manifold pressure sensor output property. Judge NG when the intake air pressure AD value is Low whereas it seemed to be High from the viewpoint of engine condition, or when it is High whereas it seemed to be Low from the engine condition.

### 2. COMPONENT DESCRIPTION

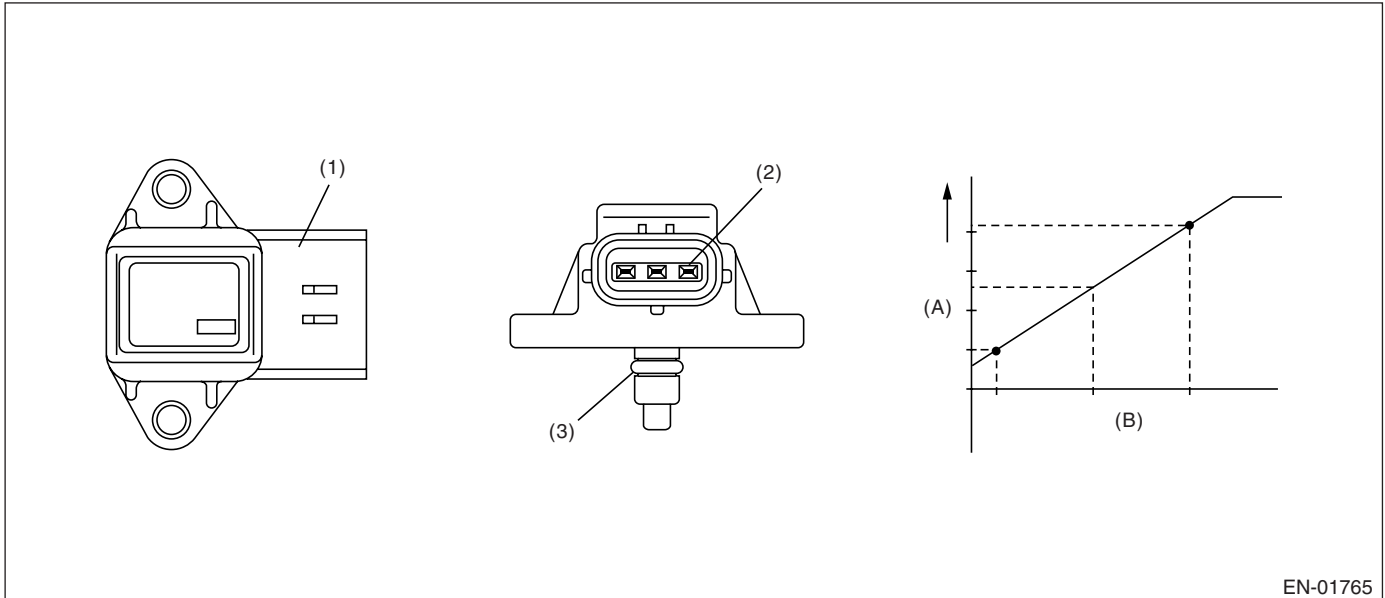

EN-01765

- |               |                       |
|---------------|-----------------------|
| (1) Connector | (A) Output voltage    |
| (2) Terminal  | (B) Absolute pressure |
| (3) O-ring    |                       |

### 3. ENABLE CONDITION

Secondary Parameters	Enable Conditions
Engine coolant temperature	$\geq 75^{\circ}\text{C}$ (167°F)

### 4. GENERAL DRIVING CYCLE

Perform the diagnosis continuously after idling.

# Diagnostic Trouble Code (DTC) Detecting Criteria

## GENERAL DESCRIPTION

---

### 5. DIAGNOSTIC METHOD

#### • Abnormality Judgment

Judge NG when either Low side or High side becomes NG. Judge NG when the continuous time of completing the malfunction criteria below becomes more than the predetermined time.

#### Judgment Value

Malfunction Criteria	Threshold Value
Low side	
Engine speed	< 2,500 rpm
Throttle position	≥ 12°
Intake air amount per engine 0.5 rev.	≥ 0.55 g (0.019 oz)/rev
Output voltage	< 1.4 V
High side	
Engine speed	600 ←→ 900 rpm
Throttle position	≤ 2.44°
Intake air amount per engine 0.5 rev.	< 0.54 g (0.014 oz)/rev
Output voltage	≥ 3.4 V

**Time Needed for Diagnosis:**Low side 3 seconds, high side 7 seconds

**Malfunction Indicator Light Illumination:**Illuminates when malfunction occurs in 2 continuous driving cycles.

#### • Normality Judgment

Judge OK and clear the NG when both Low side and High side become OK. Judge OK when the malfunction criteria below are completed.

#### Judgment Value

Malfunction Criteria	Threshold Value
Low side	
Engine speed	< 2,500 rpm
Throttle position	≥ 12°
Intake air amount per engine 0.5 rev.	≥ 0.55 g (0.019 oz)/rev
Output voltage	≥ 1.4 V
High side	
Engine speed	600 ←→ 900 rpm
Throttle position	≤ 2.44°
Intake air amount per engine 0.5 rev.	< 0.4 g (0.014 oz)/rev
Output voltage	< 3.4 V

### 6. DTC CLEAR CONDITION

- When the OK idling cycle was completed 40 times in a row
- When "Clear Memory" was performed

### 7. MALFUNCTION INDICATOR LIGHT CLEAR CONDITION

- When the OK driving cycle was completed 3 times in a row
- When "Clear Memory" was performed

### 8. FAIL SAFE

- Intake manifold pressure sensor process: Estimate the pressure from engine load.
- ISC feedback: Not allowed to calculate the amount of feedback.

### 9. ECM OPERATION AT DTC SETTING

Memorize the freeze frame data. (For test mode \$02)

# Diagnostic Trouble Code (DTC) Detecting Criteria

GENERAL DESCRIPTION

## I: DTC P0076 INTAKE VALVE CONTROL CIRCUIT LOW (BANK 1)

### 1. OUTLINE OF DIAGNOSIS

Detect the open circuit of oil switching solenoid valve.  
Judge open circuit NG when the current is small though output duty is large.

### 2. ENABLE CONDITION

Secondary Parameters	Enable Conditions
Battery voltage	$\geq 10.9$ V

### 3. GENERAL DRIVING CYCLE

Always perform the diagnosis continuously.

### 4. DIAGNOSTIC METHOD

#### • Abnormality judgment

Judge NG when the continuous time of completing malfunction criteria below becomes more than 2 seconds.

#### Judgment Value

Malfunction Criteria	Threshold Value
Duty ratio	$\geq 30\%$
Control current	$< 0.026$ A

**Time needed for diagnosis:** 2 seconds

**Malfunction Indicator Light Illumination:** Illuminates as soon as malfunction occurs.

#### • Normality Judgment

Judge OK and clear NG when the continuous time of completing the malfunction criteria below becomes more than 2 seconds.

#### Judgment Value

Malfunction Criteria	Threshold Value
Oil switching solenoid valve target current value – Oil switching solenoid valve current value	$< 0.08$ A
Control current	$\geq 0.11$ A

### 5. DTC CLEAR CONDITION

- When the OK idling cycle was completed 40 times in a row
- When “Memory Clear” was performed

### 6. MALFUNCTION INDICATOR LIGHT CLEAR CONDITION

- When the OK driving cycle was completed 3 times in a row
- When “Memory Clear” was performed

### 7. FAIL SAFE

None

### 8. ECM OPERATION AT DTC SETTING

Memorize the freeze frame data. (For test mode \$02)

# Diagnostic Trouble Code (DTC) Detecting Criteria

## GENERAL DESCRIPTION

---

### J: DTC P0077 INTAKE VALVE CONTROL CIRCUIT HIGH (BANK 1)

#### 1. OUTLINE OF DIAGNOSIS

Detect the short circuit of oil switching solenoid valve.  
Judge short circuit NG when the current is large though output duty is small.

#### 2. ENABLE CONDITION

Secondary Parameters	Enable Conditions
Battery voltage	$\geq 10.9$ V

#### 3. GENERAL DRIVING CYCLE

Always perform the diagnosis continuously.

#### 4. DIAGNOSTIC METHOD

##### • Abnormality judgment

Judge NG when the continuous time of completing malfunction criteria below becomes more than 2 seconds.

##### Judgment Value

Malfunction Criteria	Threshold Value
Duty ratio	$< 7\%$
Control current	$\geq 0.465$ A

**Time needed for diagnosis:** 2 seconds

**Malfunction Indicator Light Illumination:** Illuminates as soon as malfunction occurs.

##### • Normality Judgment

Judge OK and clear NG when the continuous time of completing the malfunction criteria below becomes more than 2 seconds.

##### Judgment Value

Malfunction Criteria	Threshold Value
Oil switching solenoid valve target current value – Oil switching solenoid valve current value	$< 0.08$ A

#### 5. DTC CLEAR CONDITION

- When the OK idling cycle was completed 40 times in a row
- When “Memory Clear” was performed

#### 6. MALFUNCTION INDICATOR LIGHT CLEAR CONDITION

- When the OK driving cycle was completed 3 times in a row
- When “Memory Clear” was performed

#### 7. FAIL SAFE

None

#### 8. ECM OPERATION AT DTC SETTING

Memorize the freeze frame data. (For test mode \$02)

# Diagnostic Trouble Code (DTC) Detecting Criteria

GENERAL DESCRIPTION

## K: DTC P0082 INTAKE VALVE CONTROL CIRCUIT LOW (BANK 2)

NOTE:

For the detecting criteria, refer to P0076. <Ref. to GD(H4SO)-21, DTC P0076 INTAKE VALVE CONTROL CIRCUIT LOW (BANK 1), Diagnostic Trouble Code (DTC) Detecting Criteria.>

## L: DTC P0083 INTAKE VALVE CONTROL CIRCUIT HIGH (BANK 2)

NOTE:

For the detecting criteria, refer to P0077. <Ref. to GD(H4SO)-22, DTC P0077 INTAKE VALVE CONTROL CIRCUIT HIGH (BANK 1), Diagnostic Trouble Code (DTC) Detecting Criteria.>

## M: DTC P0101 MASS OR VOLUME AIR FLOW CIRCUIT RANGE/PERFORMANCE

### 1. OUTLINE OF DIAGNOSIS

Detect the malfunction of air flow sensor output property. Judge Low side NG when the air flow voltage indicates low value in spite of the driving condition that the air flow voltage might be high; otherwise, judge High side NG when the air flow voltage indicates high value in spite of the driving condition that the air flow voltage might be low. Judge air flow sensor property NG when the Low side or High side becomes NG.

### 2. COMPONENT DESCRIPTION

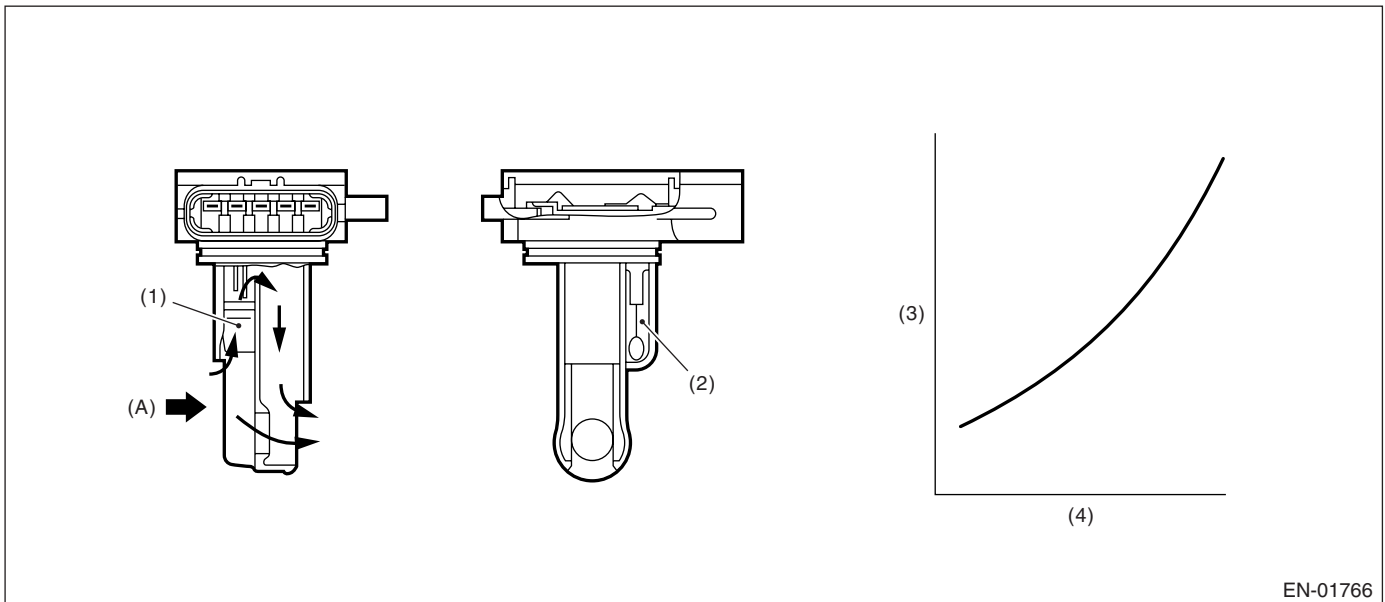

EN-01766

- (1) Air flow sensor  
(2) Intake air temperature sensor  
(3) Voltage (V)  
(4) Intake air volume (kg/s)  
(A) Air

### 3. ENABLE CONDITION

Secondary Parameters	Enable Conditions
Engine coolant temperature	$\geq 75^{\circ}\text{C}$ ( $167^{\circ}\text{F}$ )

### 4. GENERAL DRIVING CYCLE

Perform the diagnosis continuously after idling.

# Diagnostic Trouble Code (DTC) Detecting Criteria

## GENERAL DESCRIPTION

### 5. DIAGNOSTIC METHOD

#### • Abnormality Judgment

Judge NG when the continuous time of completing the malfunction criteria below becomes more than the time needed for diagnosis.

#### Judgment Value

Malfunction Criteria	Threshold Value
Low side NG Output voltage Engine speed Throttle angle Intake manifold pressure	< 1.2 V ≥ 2,000 rpm ≥ 13° ≥ 53.3 kPa (400 mmHg, 15.7 inHg)
High side NG 1 Output voltage Engine speed Throttle angle Intake manifold pressure	≥ 2.66 V 600 ↔ 900 rpm < 2.44° < 40.0 kPa (300 mmHg, 11.8 inHg)
High side NG 2 Output voltage Engine speed Throttle angle Intake manifold pressure Fuel system diagnosis	≥ 1.45 V 600 ↔ 900 rpm < 2.44° < 40.0 kPa (300 mmHg, 11.8 inHg) Rich side malfunction

#### Time Needed for Diagnosis:

Low side	3 seconds
High side	10 seconds

**Malfunction Indicator Light Illumination:** Illuminates when malfunction occurs in 2 continuous driving cycles.

#### • Normality Judgment

Judge OK the when the malfunction criteria below are completed.

#### Judgment Value

Malfunction Criteria	Threshold Value
Low side NG Output voltage Engine speed Throttle angle Intake manifold pressure	≥ 1.2 V ≥ 2,000 rpm ≥ 13° ≥ 53.3 kPa (400 mmHg, 15.7 inHg)
High side NG Output voltage Engine speed Throttle angle Intake manifold pressure	< 2.66 V 600 ↔ 900 rpm < 2.44° < 40.0 kPa (300 mmHg, 11.8 inHg)

### 6. DTC CLEAR CONDITION

- When the OK idling cycle was completed 40 times in a row
- When "Clear Memory" was performed



# Diagnostic Trouble Code (DTC) Detecting Criteria

GENERAL DESCRIPTION

## 7. MALFUNCTION INDICATOR LIGHT CLEAR CONDITION

- When the OK driving cycle was completed 3 times in a row
- When "Clear Memory" was performed

## 8. FAIL SAFE

None

## 9. ECM OPERATION AT DTC SETTING

Memorize the freeze frame data. (For test mode \$02)

## N: DTC P0102 MASS OR VOLUME AIR FLOW CIRCUIT LOW INPUT

### 1. OUTLINE OF DIAGNOSIS

Detect the open or short circuit of air flow sensor. Judge NG when out of the standard value.

### 2. COMPONENT DESCRIPTION

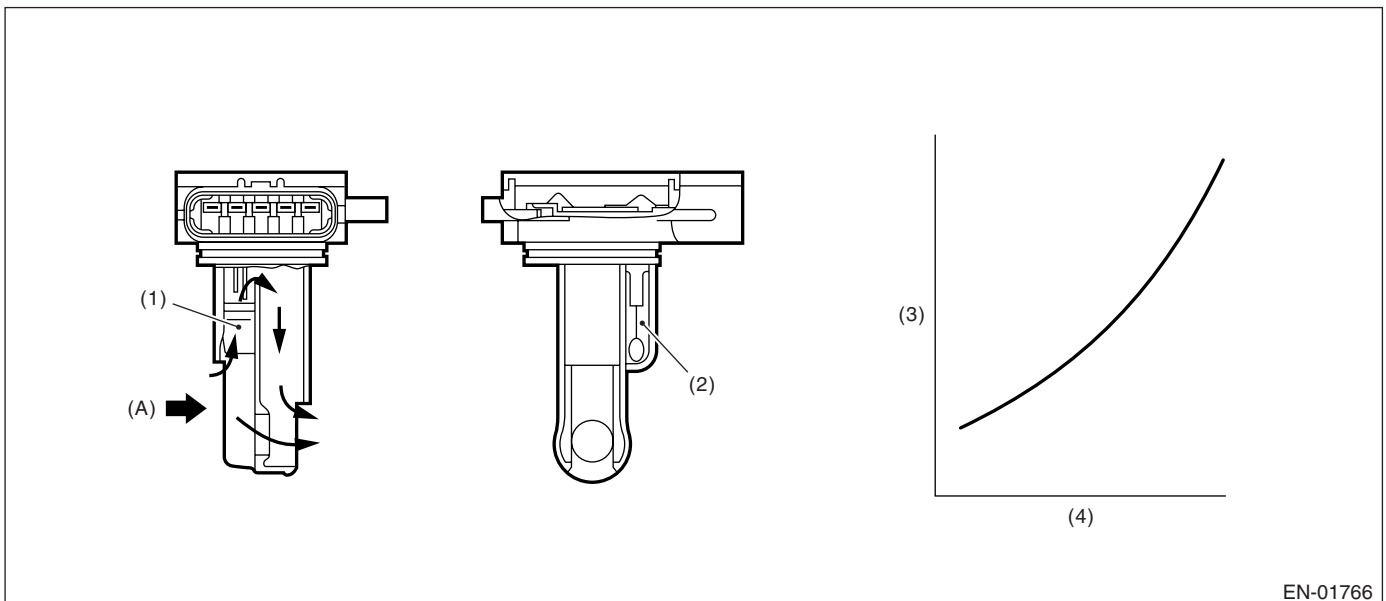

EN-01766

(1) Air flow sensor

(3) Voltage (V)

(A) Air

(2) Intake air temperature sensor

(4) Intake air volume (kg/s)

### 3. ENABLE CONDITION

Secondary Parameters	Enable Conditions
None	

### 4. GENERAL DRIVING CYCLE

Always perform the diagnosis continuously.

### 5. DIAGNOSTIC METHOD

Judge NG when the continuous time of completing the malfunction criteria below becomes more than 0.5 seconds. Judge OK and clear the NG when the malfunction criteria below are not completed.

#### Judgment Value

Malfunction Criteria	Threshold Value
Output voltage	$\leq 0.2$ V

**Time Needed for Diagnosis:**0.5 seconds

**Malfunction Indicator Light Illumination:**Illuminates as soon as the malfunction occurs.

# Diagnostic Trouble Code (DTC) Detecting Criteria

## GENERAL DESCRIPTION

### 6. DTC CLEAR CONDITION

- When the OK idling cycle was completed 40 times in a row
- When "Clear Memory" was performed

### 7. MALFUNCTION INDICATOR LIGHT CLEAR CONDITION

- When the OK driving cycle was completed 3 times in a row
- When "Clear Memory" was performed

### 8. FAIL SAFE

None

### 9. ECM OPERATION AT DTC SETTING

Memorize the freeze frame data. (For test mode \$02)

## O: DTC P0103 MASS OR VOLUME AIR FLOW CIRCUIT HIGH INPUT

### 1. OUTLINE OF DIAGNOSIS

Detect the open or short circuit of air flow sensor. Judge NG when out of the standard value.

### 2. COMPONENT DESCRIPTION

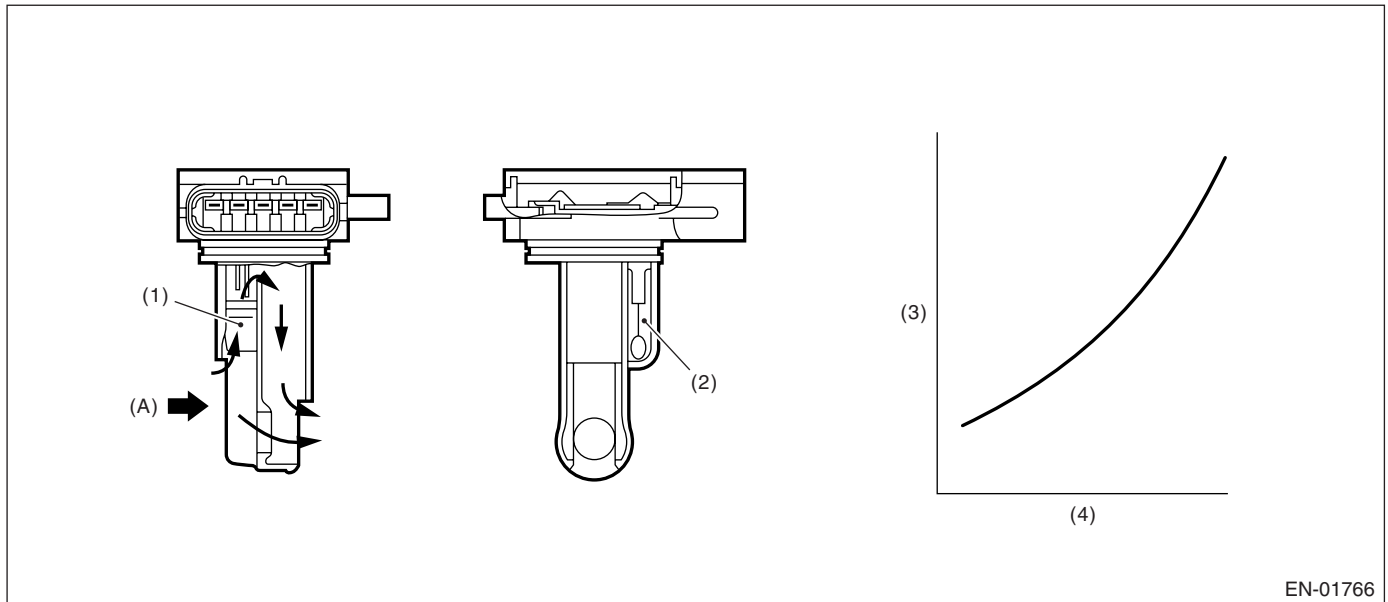

EN-01766

(1) Air flow sensor

(2) Intake air temperature sensor

(3) Voltage (V)

(4) Intake air volume (kg/s)

(A) Air

### 3. ENABLE CONDITION

Secondary Parameters	Enable Conditions
None	

### 4. GENERAL DRIVING CYCLE

Always perform the diagnosis continuously.

# Diagnostic Trouble Code (DTC) Detecting Criteria

GENERAL DESCRIPTION

## 5. DIAGNOSTIC METHOD

Judge NG when the continuous time until completing the malfunction criteria below becomes more than 0.5 seconds. Judge OK and clear the NG when the malfunction criteria below are not completed.

### Judgment Value

Malfunction Criteria	Threshold Value
Output voltage	$\geq 4.985$ V

**Time Needed for Diagnosis:**0.5 seconds

**Malfunction Indicator Light Illumination:**Illuminates as soon as the malfunction occurs.

## 6. DTC CLEAR CONDITION

- When the OK idling cycle was completed 40 times in a row
- When "Clear Memory" was performed

## 7. MALFUNCTION INDICATOR LIGHT CLEAR CONDITION

- When the OK driving cycle was completed 3 times in a row
- When "Clear Memory" was performed

## 8. FAIL SAFE

None

## 9. ECM OPERATION AT DTC SETTING

Memorize the freeze frame data. (For test mode \$02)

# Diagnostic Trouble Code (DTC) Detecting Criteria

## GENERAL DESCRIPTION

### P: DTC P0107 MANIFOLD ABSOLUTE PRESSURE/BAROMETRIC PRESSURE CIRCUIT LOW INPUT

#### 1. OUTLINE OF DIAGNOSIS

Detect the open or short circuit of intake manifold pressure sensor. Judge NG when out of the standard value.

#### 2. COMPONENT DESCRIPTION

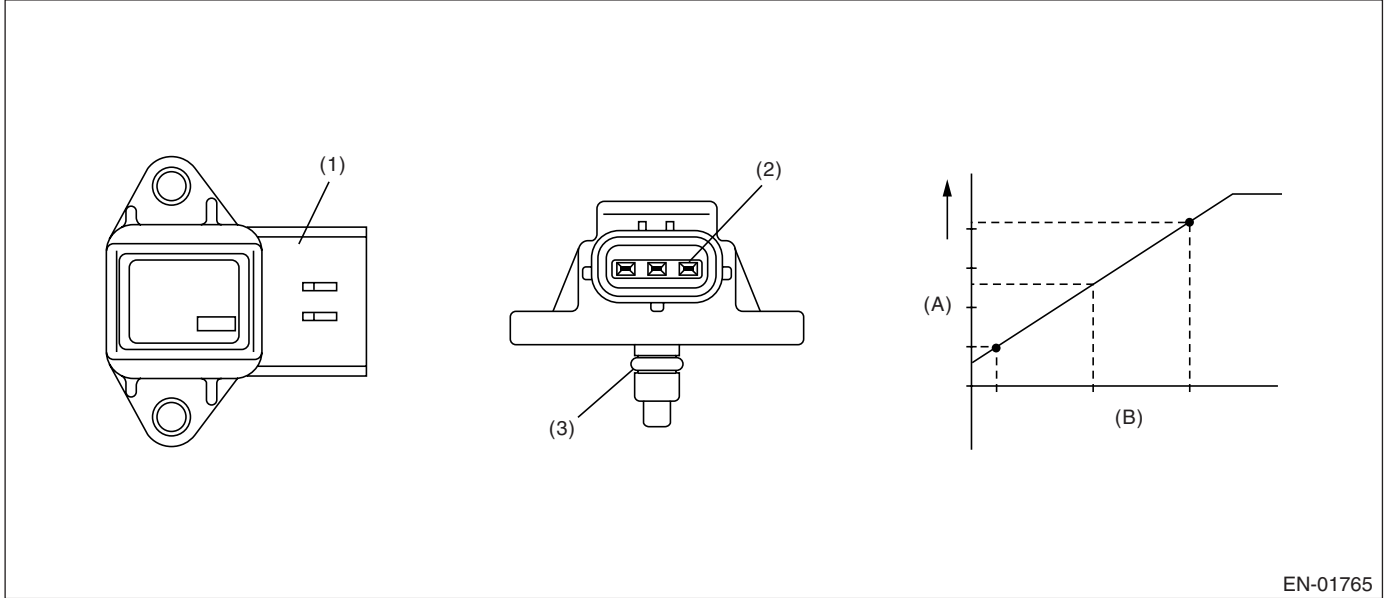

EN-01765

- |               |                       |
|---------------|-----------------------|
| (1) Connector | (A) Output voltage    |
| (2) Terminal  | (B) Absolute pressure |
| (3) O-ring    |                       |

#### 3. ENABLE CONDITION

Secondary Parameters	Enable Conditions
None	

#### 4. GENERAL DRIVING CYCLE

Always perform the diagnosis continuously.

#### 5. DIAGNOSTIC METHOD

Judge NG when the continuous time of completing the malfunction criteria below becomes more than 0.5 seconds. Judge OK and clear the NG when the malfunction criteria below are not completed.

##### Judgment Value

Malfunction Criteria	Threshold Value
Output voltage	< 0.568 V

**Time Needed for Diagnosis:** 0.5 seconds

**Malfunction Indicator Light Illumination:** Illuminates as soon as the malfunction occurs.

#### 6. DTC CLEAR CONDITION

- When the OK idling cycle was completed 40 times in a row
- When "Clear Memory" was performed

# Diagnostic Trouble Code (DTC) Detecting Criteria

GENERAL DESCRIPTION

## 7. MALFUNCTION INDICATOR LIGHT CLEAR CONDITION

- When the OK driving cycle was completed 3 times in a row
- When "Clear Memory" was performed

## 8. FAIL SAFE

ISC feedback: Not allowed to calculate the amount of feedback.

## 9. ECM OPERATION AT DTC SETTING

Memorize the freeze frame data. (For test mode \$02)

## Q: DTC P0108 MANIFOLD ABSOLUTE PRESSURE/BAROMETRIC PRESSURE CIRCUIT HIGH INPUT

### 1. OUTLINE OF DIAGNOSIS

Detect the open or short circuit of intake manifold pressure sensor. Judge NG when out of the standard value.

### 2. COMPONENT DESCRIPTION

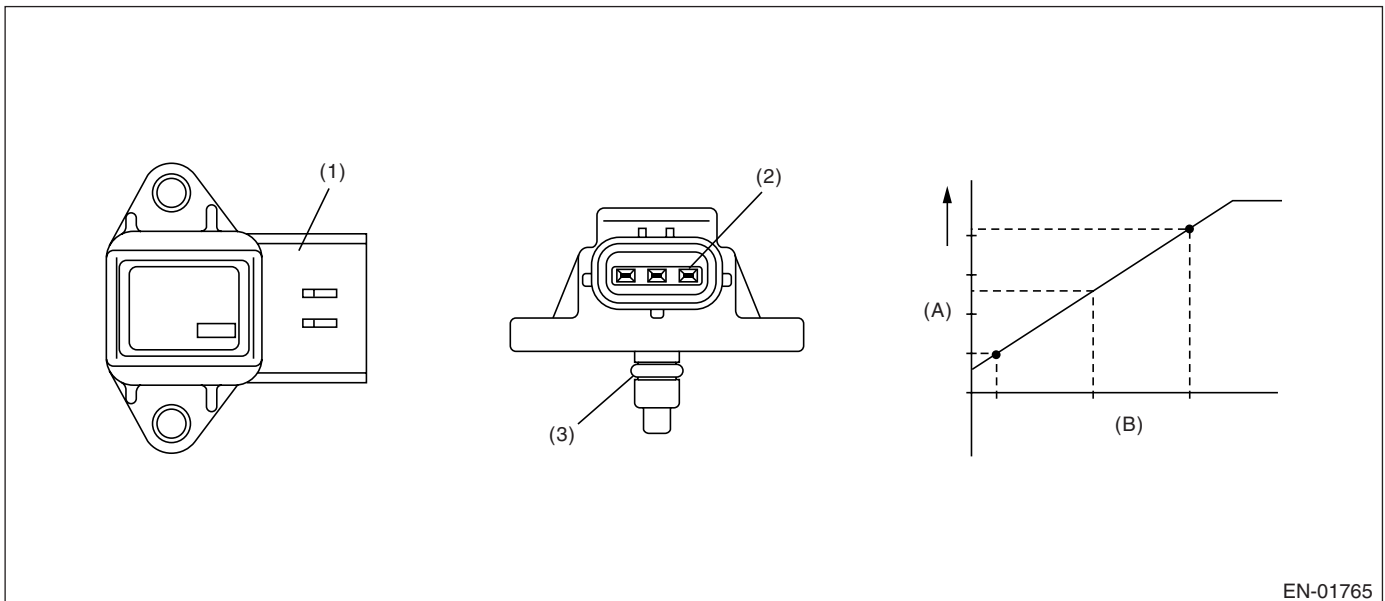

(1) Connector

(2) Terminal

(3) O-ring

(A) Output voltage

(B) Absolute pressure

### 3. ENABLE CONDITION

Secondary Parameters	Enable Conditions
None	

### 4. GENERAL DRIVING CYCLE

Always perform the diagnosis continuously.

# Diagnostic Trouble Code (DTC) Detecting Criteria

## GENERAL DESCRIPTION

### 5. DIAGNOSTIC METHOD

Judge NG when the continuous time of completing the malfunction criteria below becomes more than 0.5 seconds. Judge OK and clear the NG when the malfunction criteria below are not completed.

#### Judgment Value

Malfunction Criteria	Threshold Value
Output voltage	$\geq 4.921$ V

**Time Needed for Diagnosis:** 0.5 seconds

**Malfunction Indicator Light Illumination:** Illuminates as soon as the malfunction occurs.

### 6. DTC CLEAR CONDITION

- When the OK idling cycle was completed 40 times in a row
- When "Clear Memory" was performed

### 7. MALFUNCTION INDICATOR LIGHT CLEAR CONDITION

- When the OK driving cycle was completed 3 times in a row
- When "Clear Memory" was performed

### 8. FAIL SAFE

ISC feedback: Not allowed to calculate the amount of feedback.

### 9. ECM OPERATION AT DTC SETTING

Memorize the freeze frame data. (For test mode \$02)

## R: DTC P0111 INTAKE AIR TEMPERATURE CIRCUIT RANGE/PERFORMANCE

### 1. OUTLINE OF DIAGNOSIS

Detect the malfunction of intake air temperature sensor output property. Judge NG when the intake air temperature is not varied whereas it seemed to be varied from the viewpoint of engine condition.

### 2. COMPONENT DESCRIPTION

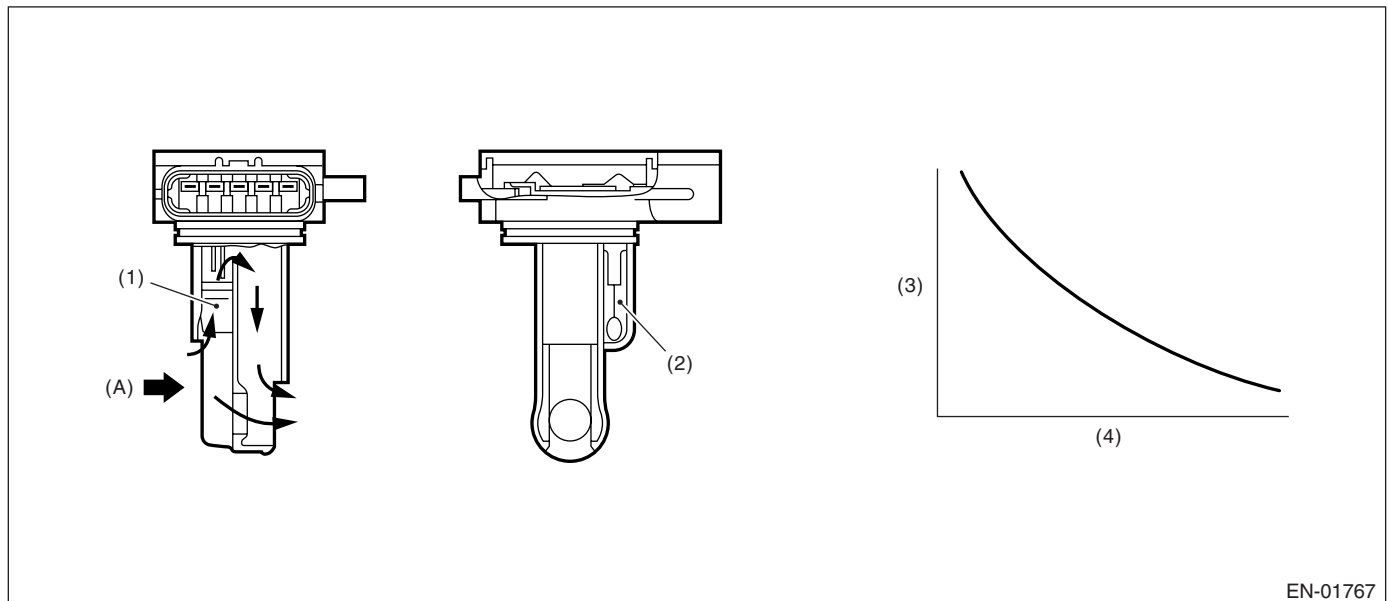

EN-01767

(1) Air flow sensor

(3) Resistance value ( $\Omega$ )

(A) Air

(2) Intake air temperature sensor

(4) Intake air temperature  $^{\circ}\text{C}$  ( $^{\circ}\text{F}$ )

# Diagnostic Trouble Code (DTC) Detecting Criteria

GENERAL DESCRIPTION

## 3. ENABLE CONDITION

Secondary Parameters	Enable Conditions
Coolant temp. before engine start	< 30°C (86°F)
Engine coolant temperature	> 100°C (212°F)
Battery voltage	≥ 10.9 V
Continuous time when the vehicle speed is less than 60 km/h (37 MPH)	600 seconds or more

## 4. GENERAL DRIVING CYCLE

Perform the diagnosis when the vehicle speed condition is completed after idling from starting the cooled engine.

## 5. DIAGNOSTIC METHOD

### • Abnormality Judgment

Judge NG when the continuous time of completing the malfunction criteria below becomes more than 1 second.

### Judgment Value

Malfunction Criteria	Threshold Value
Output voltage difference between Max. and Min.	< 20 mV (It is equal to approx. 0.5°C (0.9°F) around 25°.)

**Time Needed for Diagnosis:** 1 second

**Malfunction Indicator Light Illumination:** Illuminates when malfunction occurs in 2 continuous driving cycles.

### • Normality Judgment

Judge OK and clear the NG when the malfunction criteria below are completed.

### Judgment Value

Malfunction Criteria	Threshold Value
Output voltage difference between Max. and Min.	≥ 20 mV

## 6. DTC CLEAR CONDITION

- When the OK idling cycle was completed 40 times in a row
- When "Clear Memory" was performed

## 7. MALFUNCTION INDICATOR LIGHT CLEAR CONDITION

- When the OK driving cycle was completed 3 times in a row
- When "Clear Memory" was performed

## 8. FAIL SAFE

Intake air temperature sensor process: Intake air temperature is fixed at 20°C (68°F).

## 9. ECM OPERATION AT DTC SETTING

Memorize the freeze frame data. (For test mode \$02)

# Diagnostic Trouble Code (DTC) Detecting Criteria

## GENERAL DESCRIPTION

### S: DTC P0112 INTAKE AIR TEMPERATURE CIRCUIT LOW INPUT

#### 1. OUTLINE OF DIAGNOSIS

Detect the open or short circuit of intake air temperature sensor. Judge NG when out of the standard value.

#### 2. COMPONENT DESCRIPTION

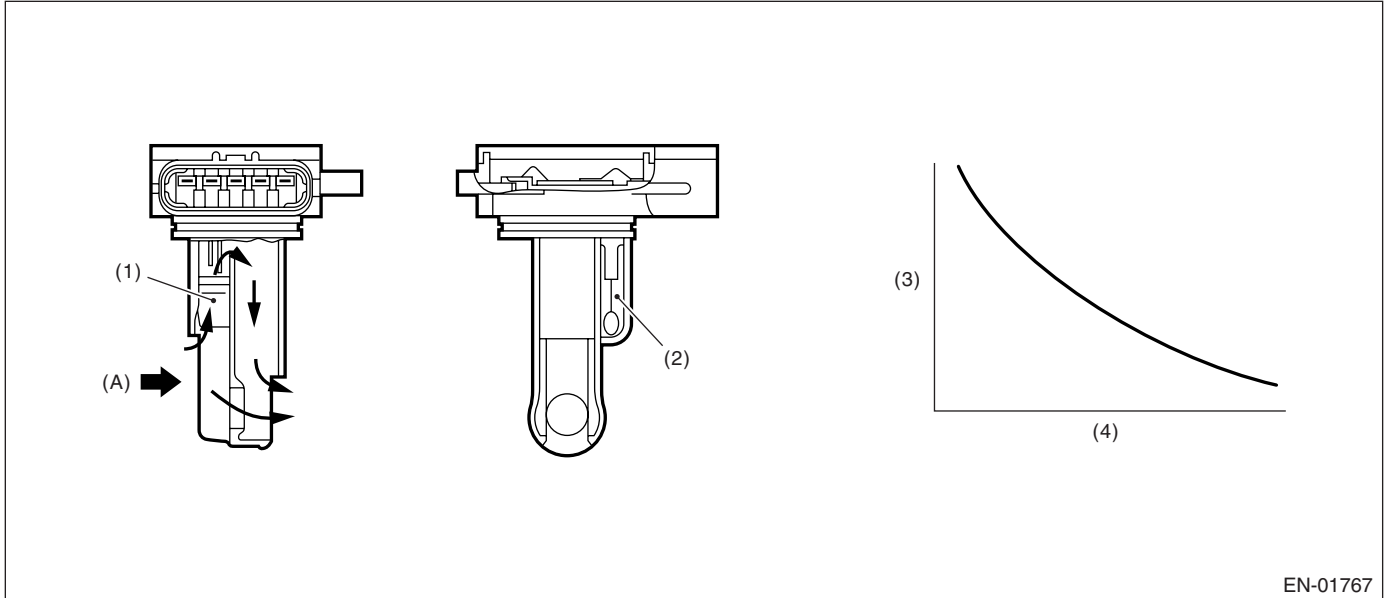

EN-01767

(1) Air flow sensor

(3) Resistance value ( $\Omega$ )

(A) Air

(2) Intake air temperature sensor

(4) Intake air temperature °C (°F)

#### 3. ENABLE CONDITION

Secondary Parameters	Enable Conditions
None	

#### 4. GENERAL DRIVING CYCLE

Always perform the diagnosis continuously.

#### 5. DIAGNOSTIC METHOD

##### • Abnormality Judgment

Judge NG when the continuous time of completing the malfunction criteria below becomes more than 0.5 seconds.

##### Judgment Value

Malfunction Criteria	Threshold Value
Output voltage	< 0.166 V
Ignition switch	ON

**Time Needed for Diagnosis:** 0.5 seconds

**Malfunction Indicator Light Illumination:** Illuminates as soon as the malfunction occurs.

##### • Normality Judgment

Judge OK and clear the NG when the malfunction criteria below are completed.

##### Judgment Value

Malfunction Criteria	Threshold Value
Output voltage	$\geq 0.166$ V
Ignition switch	ON



## 6. DTC CLEAR CONDITION

- When the OK idling cycle was completed 40 times in a row
- When “Clear Memory” was performed

## 7. MALFUNCTION INDICATOR LIGHT CLEAR CONDITION

- When the OK driving cycle was completed 3 times in a row
- When “Clear Memory” was performed

## 8. FAIL SAFE

Intake air temperature sensor process: Intake air temperature is fixed at 20°C (68°F).

## 9. ECM OPERATION AT DTC SETTING

Memorize the freeze frame data. (For test mode \$02)

## T: DTC P0113 INTAKE AIR TEMPERATURE CIRCUIT HIGH INPUT

### 1. OUTLINE OF DIAGNOSIS

Detect the open or short circuit of intake air temperature sensor. Judge NG when out of the standard value.

### 2. COMPONENT DESCRIPTION

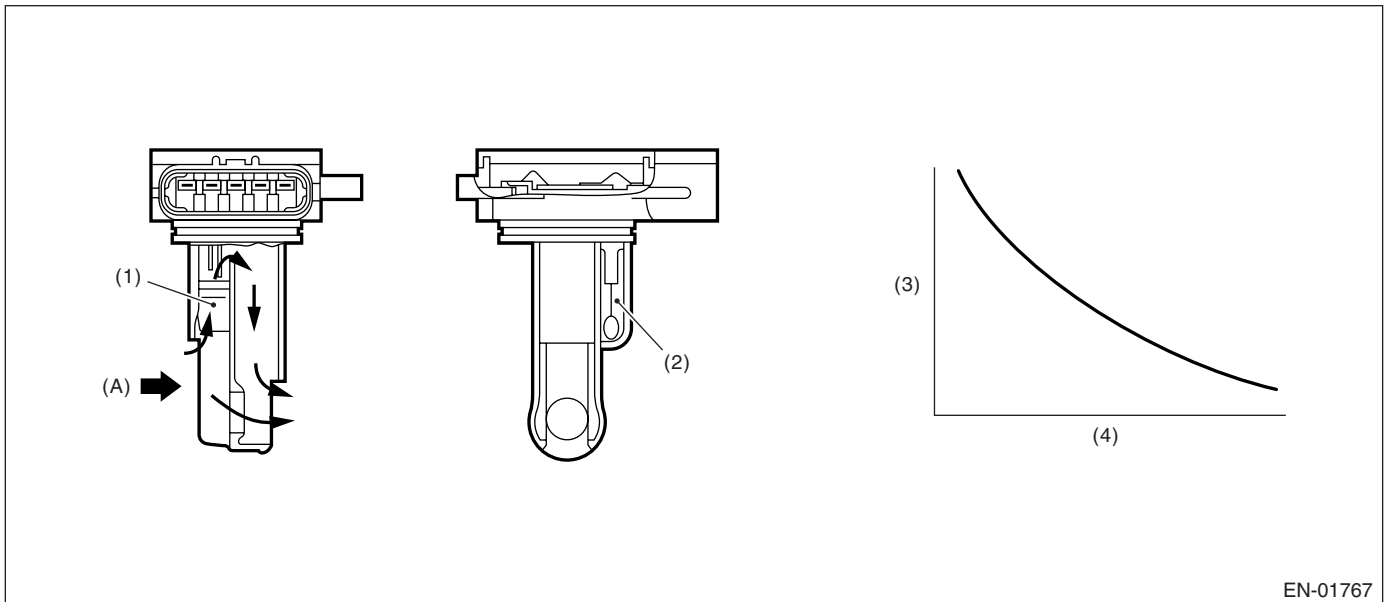

EN-01767

- |                                   |                                    |         |
|-----------------------------------|------------------------------------|---------|
| (1) Air flow sensor               | (3) Resistance value ( $\Omega$ )  | (A) Air |
| (2) Intake air temperature sensor | (4) Intake air temperature °C (°F) |         |

### 3. ENABLE CONDITION

Secondary Parameters	Enable Conditions
None	

### 4. GENERAL DRIVING CYCLE

Always perform the diagnosis continuously.

# Diagnostic Trouble Code (DTC) Detecting Criteria

## GENERAL DESCRIPTION

---

### 5. DIAGNOSTIC METHOD

#### • Abnormality Judgment

Judge NG when the continuous time of completing the malfunction criteria below becomes more than 0.5 seconds.

#### Judgment Value

Malfunction Criteria	Threshold Value
Output voltage	$\geq 4.716$ V
Ignition switch	ON

**Time Needed for Diagnosis:**0.5 seconds

**Malfunction Indicator Light Illumination:**Illuminates as soon as the malfunction occurs.

#### • Normality Judgment

Judge OK and clear the NG when the malfunction criteria below are completed.

#### Judgment Value

Malfunction Criteria	Threshold Value
Output voltage	$< 4.716$ V
Ignition switch	ON

### 6. DTC CLEAR CONDITION

- When the OK idling cycle was completed 40 times in a row
- When "Clear Memory" was performed

### 7. MALFUNCTION INDICATOR LIGHT CLEAR CONDITION

- When the OK driving cycle was completed 3 times in a row
- When "Clear Memory" was performed

### 8. FAIL SAFE

Intake air temperature sensor process: Intake air temperature is fixed at 20°C (68°F).

### 9. ECM OPERATION AT DTC SETTING

Memorize the freeze frame data. (For test mode \$02)

## U: DTC P0117 ENGINE COOLANT TEMPERATURE CIRCUIT LOW INPUT

### 1. OUTLINE OF DIAGNOSIS

Detect the open or short circuit of engine coolant temperature sensor. Judge NG when out of the standard value.

### 2. COMPONENT DESCRIPTION

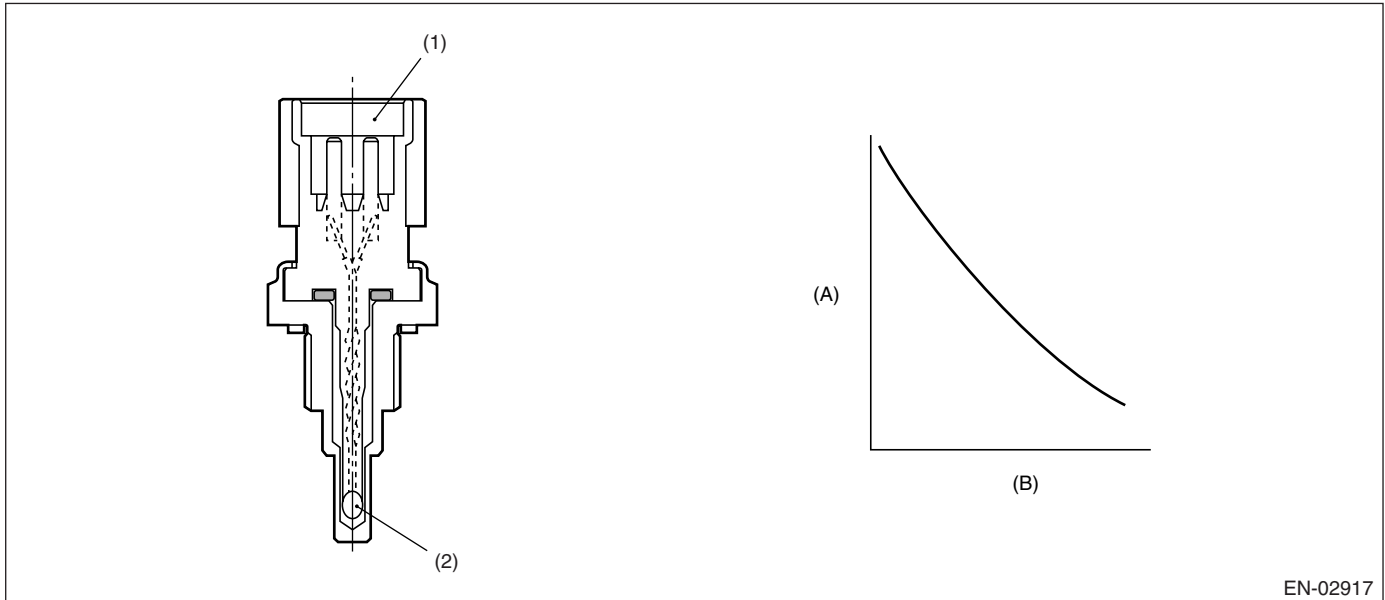

EN-02917

- |                        |                           |
|------------------------|---------------------------|
| (1) Connector          | (A) Resistance value (kΩ) |
| (2) Thermistor element | (B) Temperature °C (°F)   |

### 3. ENABLE CONDITION

Secondary Parameters	Enable Conditions
None	

### 4. GENERAL DRIVING CYCLE

Always perform the diagnosis continuously.

### 5. DIAGNOSTIC METHOD

Judge NG when the continuous time of completing the malfunction criteria below becomes more than 0.5 seconds. Judge OK and clear the NG when the malfunction criteria below are not completed.

#### Judgment Value

Malfunction Criteria	Threshold Value
Output voltage	< 0.166 V

**Time Needed for Diagnosis:**0.5 seconds

**Malfunction Indicator Light Illumination:**Illuminates as soon as the malfunction occurs.

### 6. DTC CLEAR CONDITION

- When the OK idling cycle was completed 40 times in a row
- When "Clear Memory" was performed

### 7. MALFUNCTION INDICATOR LIGHT CLEAR CONDITION

- When the OK driving cycle was completed 3 times in a row
- When "Clear Memory" was performed

# Diagnostic Trouble Code (DTC) Detecting Criteria

## GENERAL DESCRIPTION

### 8. FAIL SAFE

- Engine coolant temperature process: Fix the engine coolant temperature at 70°C (158°F).
- ISC feedback: Calculate the target engine speed setting the engine coolant temperature to 70°C (158°F).
- ISC learning: Not allowed to learn.
- Heavy fuel judgment control: Not allowed to carry out the heavy judgment.
- Air conditioner control: Not allowed to turn the air conditioner to ON.
- Radiator fan control: Both main and sub fan turn to ON.
- Tumble generator valve control: Open the tumble generator valve.

### 9. ECM OPERATION AT DTC SETTING

Memorize the freeze frame data. (For test mode \$02)

## V: DTC P0118 ENGINE COOLANT TEMPERATURE CIRCUIT HIGH INPUT

### 1. OUTLINE OF DIAGNOSIS

Detect the open or short circuit of engine coolant temperature sensor. Judge NG when out of the standard value.

### 2. COMPONENT DESCRIPTION

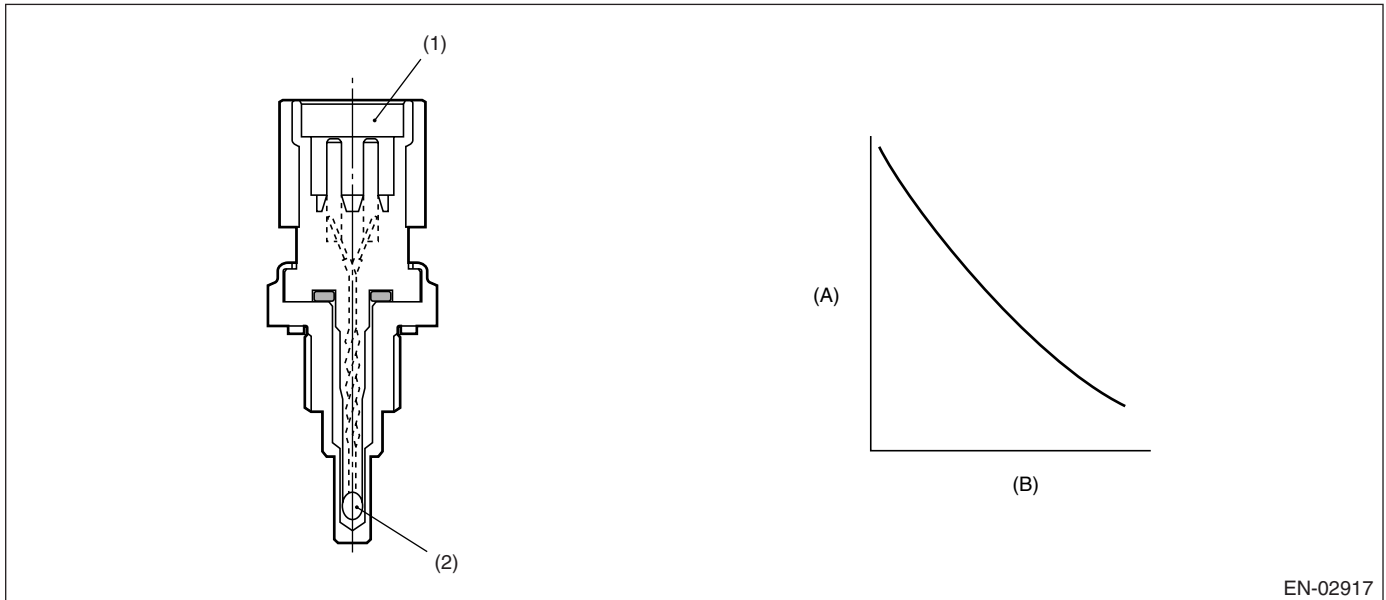

EN-02917

- (1) Connector
- (2) Thermistor element

- (A) Resistance value (k $\Omega$ )
- (B) Temperature °C (°F)

### 3. ENABLE CONDITION

Secondary Parameters	Enable Conditions
None	

### 4. GENERAL DRIVING CYCLE

Always perform the diagnosis continuously.

# Diagnostic Trouble Code (DTC) Detecting Criteria

GENERAL DESCRIPTION

## 5. DIAGNOSTIC METHOD

Judge NG when the continuous time of completing the malfunction criteria below becomes more than 0.5 seconds. Judge OK and clear the NG when the malfunction criteria below are not completed.

### Judgment Value

Malfunction Criteria	Threshold Value
Output voltage	$\geq 4.716$ V

**Time Needed for Diagnosis:**0.5 seconds

**Malfunction Indicator Light Illumination:**Illuminates as soon as the malfunction occurs.

## 6. DTC CLEAR CONDITION

- When the OK idling cycle was completed 40 times in a row
- When "Clear Memory" was performed

## 7. MALFUNCTION INDICATOR LIGHT CLEAR CONDITION

- When the OK driving cycle was completed 3 times in a row
- When "Clear Memory" was performed

## 8. FAIL SAFE

- Engine coolant temperature process: Fix the engine coolant temperature at 70°C (158°F).
- ISC feedback: Calculate the target engine speed setting the engine coolant temperature to 70°C (158°F).
- ISC learning: Not allowed to learn.
- Air conditioner control: Not allowed to turn the air conditioner to ON.
- Radiator fan control: Both main and sub fan turn to ON.
- Tumble generator valve control: Open the tumble generator valve.

## 9. ECM OPERATION AT DTC SETTING

Memorize the freeze frame data. (For test mode \$02)

# Diagnostic Trouble Code (DTC) Detecting Criteria

## GENERAL DESCRIPTION

### W: DTC P0122 THROTTLE/PEDAL POSITION SENSOR/SWITCH “A” CIRCUIT LOW INPUT

#### 1. OUTLINE OF DIAGNOSIS

Detect the open or short circuit of throttle position sensor 1.  
Judge NG when out of the standard value.

#### 2. COMPONENT DESCRIPTION

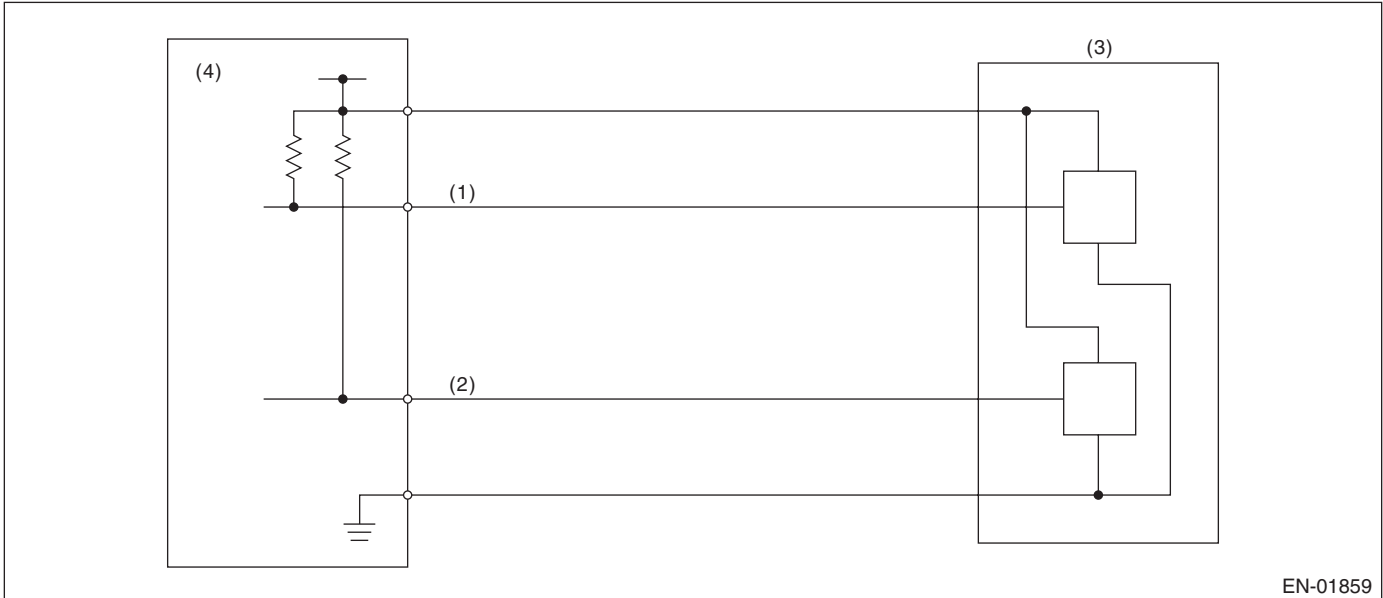

EN-01859

- |                                       |                                 |
|---------------------------------------|---------------------------------|
| (1) Throttle position sensor 1 signal | (3) Throttle position sensor    |
| (2) Throttle position sensor 2 signal | (4) Engine control module (ECM) |

#### 3. ENABLE CONDITION

Secondary Parameters	Enable Conditions
Ignition switch	ON

#### 4. GENERAL DRIVING CYCLE

Always perform the diagnosis continuously.

#### 5. DIAGNOSTIC METHOD

Judge OK and clear the NG when the malfunction criteria below are completed.

##### Judgment Value

Malfunction Criteria	Threshold Value
Sensor 1 input voltage	$\geq 0.309$ V

**Time Needed for Diagnosis:** 24 milliseconds

**Malfunction Indicator Light Illumination:** Illuminates as soon as malfunction occurs.

#### 6. DTC CLEAR CONDITION

- When the OK idling cycle was completed 40 times in a row
- When “Clear Memory” was performed (Only with engine stopped)

#### 7. MALFUNCTION INDICATOR LIGHT CLEAR CONDITION

- When the OK driving cycle was completed 3 times in a row
- When “Clear Memory” was performed (Only with engine stopped)

# Diagnostic Trouble Code (DTC) Detecting Criteria

GENERAL DESCRIPTION

## 8. FAIL SAFE

Stop power distribution to electronic throttle control motor. (Throttle opening is fixed to 6°.)

## 9. ECM OPERATION AT DTC SETTING

Memorize the freeze frame data. (For test mode \$02)

## X: DTC P0123 THROTTLE/PEDAL POSITION SENSOR/SWITCH "A" CIRCUIT HIGH INPUT

### 1. OUTLINE OF DIAGNOSIS

Detect the open or short circuit of throttle position sensor 1.  
Judge NG when out of the standard value.

### 2. COMPONENT DESCRIPTION

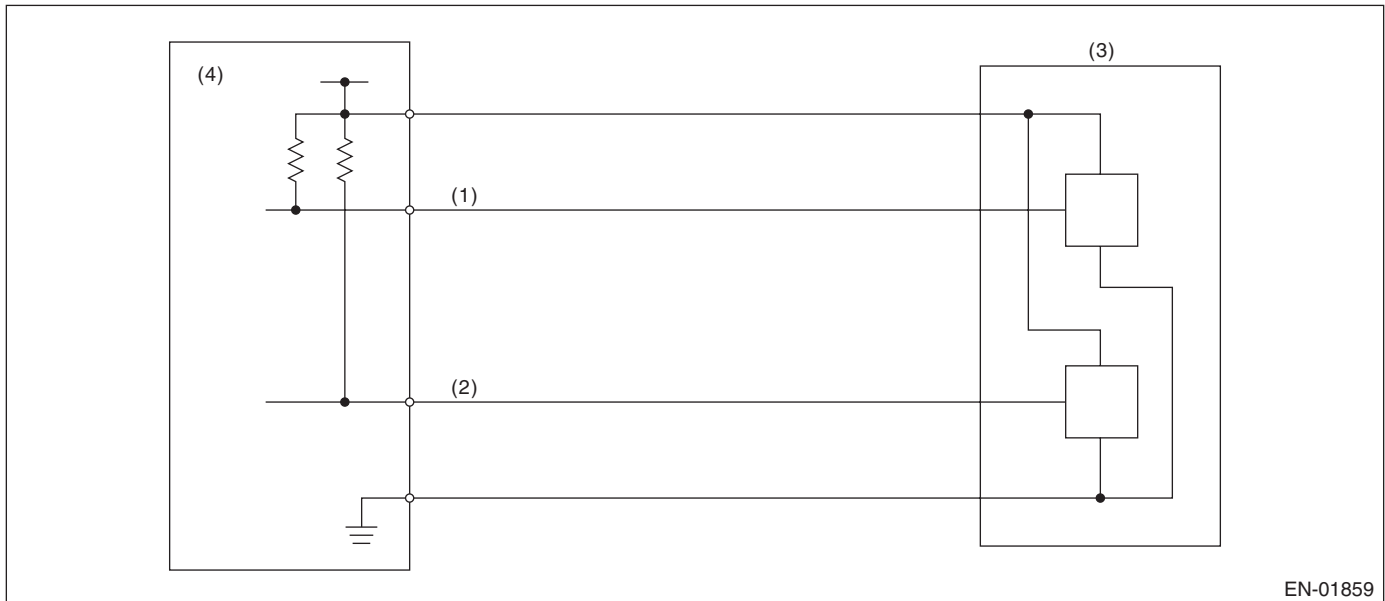

EN-01859

- (1) Throttle position sensor 1 signal      (3) Throttle position sensor  
(2) Throttle position sensor 2 signal      (4) Engine control module (ECM)

### 3. ENABLE CONDITION

Secondary Parameters	Enable Conditions
Ignition switch	ON

### 4. GENERAL DRIVING CYCLE

Always perform the diagnosis continuously.

### 5. DIAGNOSTIC METHOD

Judge OK and clear the NG when the malfunction criteria below are completed.

#### Judgment Value

Malfunction Criteria	Threshold Value
Sensor 1 input voltage	$\leq 4.646$ V

**Time Needed for Diagnosis:** 24 milliseconds

**Malfunction Indicator Light Illumination:** Illuminates as soon as malfunction occurs.

# Diagnostic Trouble Code (DTC) Detecting Criteria

## GENERAL DESCRIPTION

### 6. DTC CLEAR CONDITION

- When the OK idling cycle was completed 40 times in a row
- When "Clear Memory" was performed (Only with engine stopped)

### 7. MALFUNCTION INDICATOR LIGHT CLEAR CONDITION

- When the OK driving cycle was completed 3 times in a row
- When "Clear Memory" was performed (Only with engine stopped)

### 8. FAIL SAFE

Stop power distribution to electronic throttle control motor. (Throttle opening is fixed to 6°.)

### 9. ECM OPERATION AT DTC SETTING

Memorize the freeze frame data. (For test mode \$02)

## Y: DTC P0125 INSUFFICIENT COOLANT TEMPERATURE FOR CLOSED LOOP FUEL CONTROL

### 1. OUTLINE OF DIAGNOSIS

Detect the malfunction of engine coolant temperature output property. Judge NG when the engine coolant temperature does not rise whereas it seemed to rise from the viewpoint of the engine condition.

### 2. COMPONENT DESCRIPTION

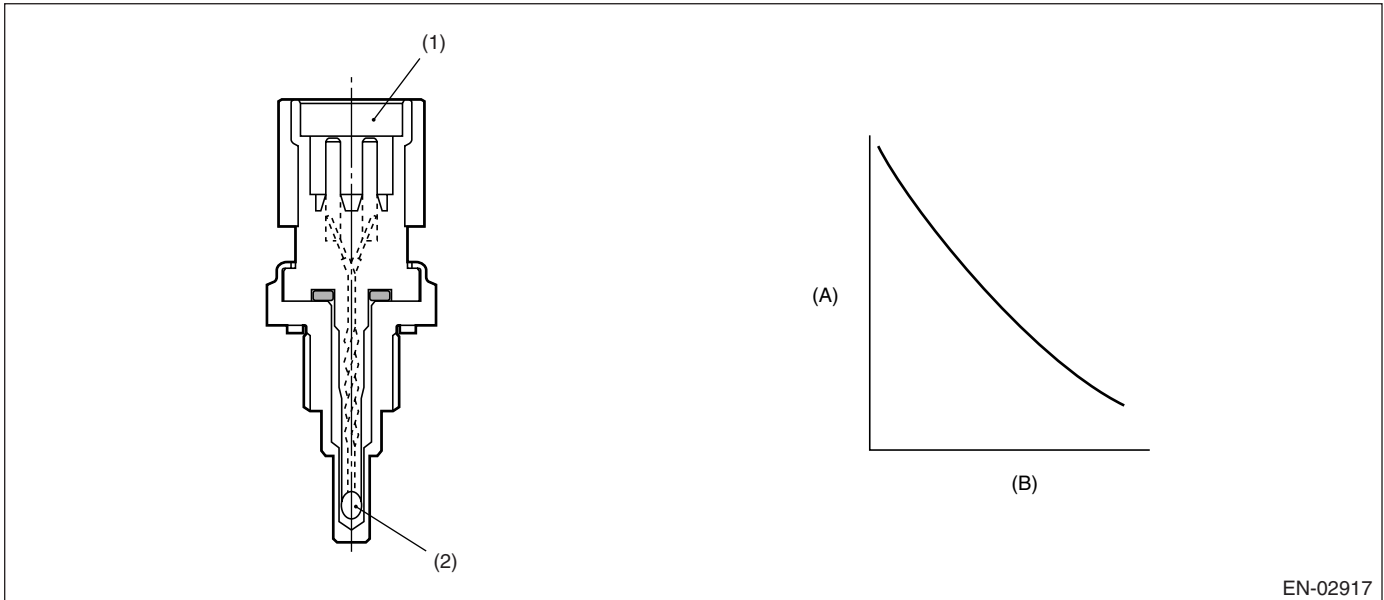

EN-02917

- (1) Connector
- (2) Thermistor element

- (A) Resistance value (k $\Omega$ )
- (B) Temperature °C (°F)

### 3. ENABLE CONDITION

Secondary Parameters	Enable Conditions
Engine speed	$\geq 500$ rpm
Battery voltage	$> 10.9$ V

### 4. GENERAL DRIVING CYCLE

Perform the diagnosis only once after engine starting.



# Diagnostic Trouble Code (DTC) Detecting Criteria

GENERAL DESCRIPTION

## 5. DIAGNOSTIC METHOD

### • Abnormality Judgment

Judge NG when the malfunction criteria below are completed.

#### Judgment Value

Malfunction Criteria	Threshold Value
Engine coolant temperature	< 20°C (68°F)
Timer for diagnosis after engine starting	≥ Timer judgment value after engine starting

Timer for diagnosis after engine starting

- Timer stop at fuel cut mode.
- During the driving conditions (except a) above), timer count up by 64 milliseconds + TWCNT milliseconds at every 64 milliseconds.

Where, TWCNT is determined as follows,

TWCNT = 0 at idle switch ON,

TWCNT show on the following table at idle switch OFF.

		Vehicle speed km/h (MPH)							
		0 (0)	8 (4.97)	16 (9.94)	24 (14.9)	32 (19.9)	40 (24.9)	48 (29.8)	56 (34.8)
Temperature °C (°F)	-20 (-4)	0 ms	32.076 ms	39.977 ms	47.879 ms	82.544 ms	117.209 ms	154.214 ms	185.206 ms
	-10 (14)	0 ms	25.704 ms	33.606 ms	41.508 ms	68.520 ms	95.532 ms	125.667 ms	155.802 ms
	0 (32)	0 ms	17.646 ms	25.548 ms	33.450 ms	53.652 ms	73.855 ms	97.120 ms	120.386 ms
	10 (50)	0 ms	7.901 ms	15.802 ms	23.704 ms	37.941 ms	52.177 ms	68.573 ms	82.538 ms

Judgment value of timer after engine starting

$$t = 574 - 33 \times T_i \text{ (Sec.)}$$

$T_i$  is the lowest coolant temperature after starting the engine.

**Time Needed for Diagnosis:** To be determined. (It is varied by the Min. engine coolant temperature and engine conditions such as vehicle speed and engine coolant temperature.)

**Malfunction Indicator Light Illumination:** Illuminates when malfunction occurs in 2 continuous driving cycles.

### • Normality Judgment

Judge OK and clear the NG when the malfunction criteria below are completed.

#### Judgment Value

Malfunction Criteria	Threshold Value
Engine coolant temperature	≥ 20°C (68°F)

## 6. DTC CLEAR CONDITION

- When the OK idling cycle was completed 40 times in a row
- When "Clear Memory" was performed

## 7. MALFUNCTION INDICATOR LIGHT CLEAR CONDITION

- When the OK driving cycle was completed 3 times in a row
- When "Clear Memory" was performed

## 8. FAIL SAFE

- Engine coolant temperature process: Fix the engine coolant temperature at 70°C (158°F).
- ISC feedback: Calculate the target engine speed setting the engine coolant temperature to 70°C (158°F).
- ISC learning: Not allowed to learn.
- Air conditioner control: Not allowed to turn the air conditioner to ON.
- Radiator fan control: Both main and sub fan turn to ON.
- Tumble generator valve control: Open the tumble generator valve.

# Diagnostic Trouble Code (DTC) Detecting Criteria

## GENERAL DESCRIPTION

### 9. ECM OPERATION AT DTC SETTING

Memorize the freeze frame data. (For test mode \$02)

## Z: DTC P0126 INSUFFICIENT ENGINE COOLANT TEMPERATURE FOR STABLE OPERATION

### 1. OUTLINE OF DIAGNOSIS

Detect the malfunction of engine coolant temperature sensor property.

The engine coolant temperature and fuel temperature are memorized when stopping the engine at the previous time. Judge NG when the engine coolant temperature does not decrease in the case the engine coolant temperature seems to decrease after starting the engine this time.

### 2. COMPONENT DESCRIPTION

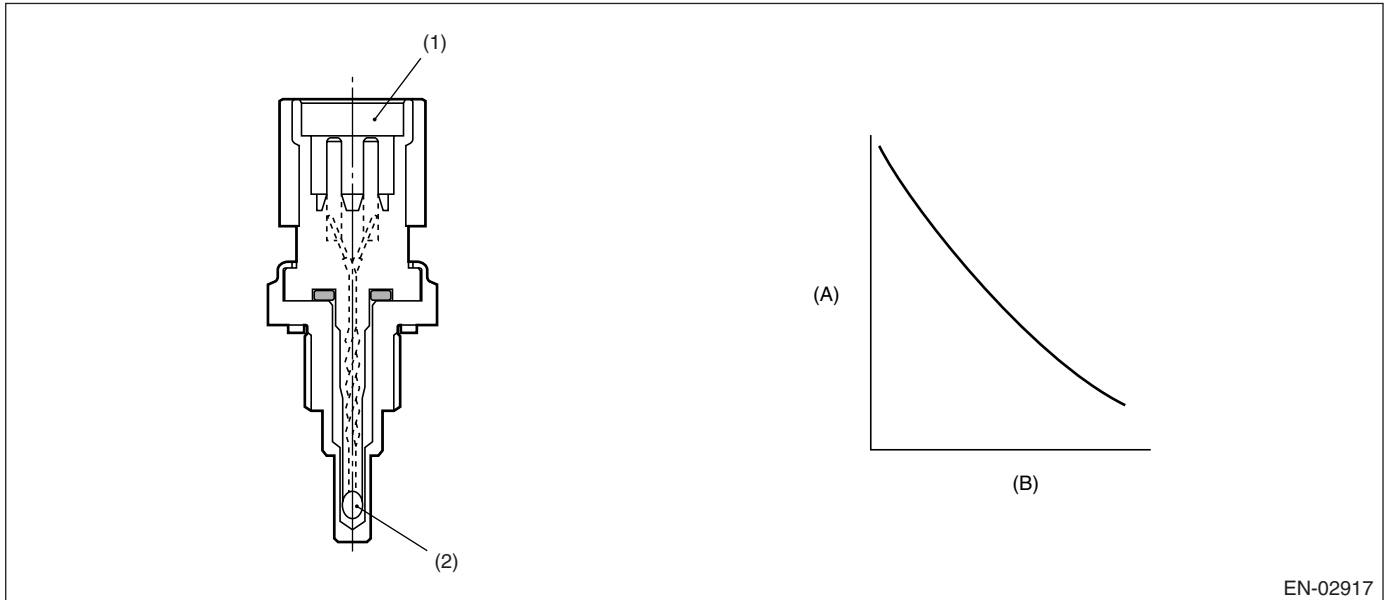

EN-02917

- (1) Connector
- (2) Thermistor element

- (A) Resistance value (k $\Omega$ )
- (B) Temperature °C (°F)

### 3. ENABLE CONDITION

Secondary Parameters	Enable Conditions
Battery voltage	$\geq 10.9$ V
Filling fuel from stopping engine at the previous time to starting it this time	No
Fuel level	15 $\ell$
Engine coolant temperature when stopping engine at the previous time	$\geq 75^{\circ}\text{C}$ (167°F) and $< 100^{\circ}\text{C}$ (212°F)

### 4. GENERAL DRIVING CYCLE

Perform the diagnosis once after starting the engine.

# Diagnostic Trouble Code (DTC) Detecting Criteria

GENERAL DESCRIPTION

## 5. DIAGNOSTIC METHOD

### • Abnormality Judgment

Judge NG when the cumulative time of completing the malfunction criteria below becomes more than 2.5 seconds.

### Judgment Value

Malfunction Criteria	Threshold Value
Engine coolant temperature when stopping engine at the previous time – The lowest engine coolant temperature after starting engine	< 2.5°C (4.5°F)
Fuel temperature when stopping engine at the previous time – Fuel temperature	5°C (9°F)
Intake air temperature – Fuel temperature	2.5°C (4.5°F)
Fuel temperature	35°C (95°F)

### • Normality Judgment

Judge OK when the malfunction criteria below are completed.

### Judgment Value

Malfunction Criteria	Threshold Value
Engine coolant temperature when stopping engine at the previous time – The lowest engine coolant temperature after starting engine	≥ 2.5°C (4.5°F)

**Time Needed for Diagnosis:** 2.5 seconds

**Malfunction Indicator Light Illuminations:** Detect when malfunction occurs in 2 continuous driving cycles.

## 6. DTC CLEAR CONDITION

- When the OK idling cycle is completed 40 times in a row
- When “Clear Memory” was performed

## 7. MALFUNCTION INDICATOR LIGHT CLEAR CONDITION

- When the OK idling cycle was completed 40 times in a row
- When “Clear Memory” was performed

## 8. FAIL SAFE

None

## 9. ECM OPERATION AT DTC SETTING

Memorize the freeze frame data. (For test mode \$02)

# Diagnostic Trouble Code (DTC) Detecting Criteria

## GENERAL DESCRIPTION

### AA:DTC P0128 COOLANT THERMOSTAT (COOLANT TEMPERATURE BELOW THERMOSTAT REGULATING TEMPERATURE)

#### 1. OUTLINE OF DIAGNOSIS

Detect the malfunction of thermostat function. Judge NG when the engine coolant temperature is lower than the estimated engine coolant temperature and the difference between them is large. Judge OK when the engine coolant temperature becomes 70°C (158°F) and the difference is small before judging NG.

#### 2. COMPONENT DESCRIPTION

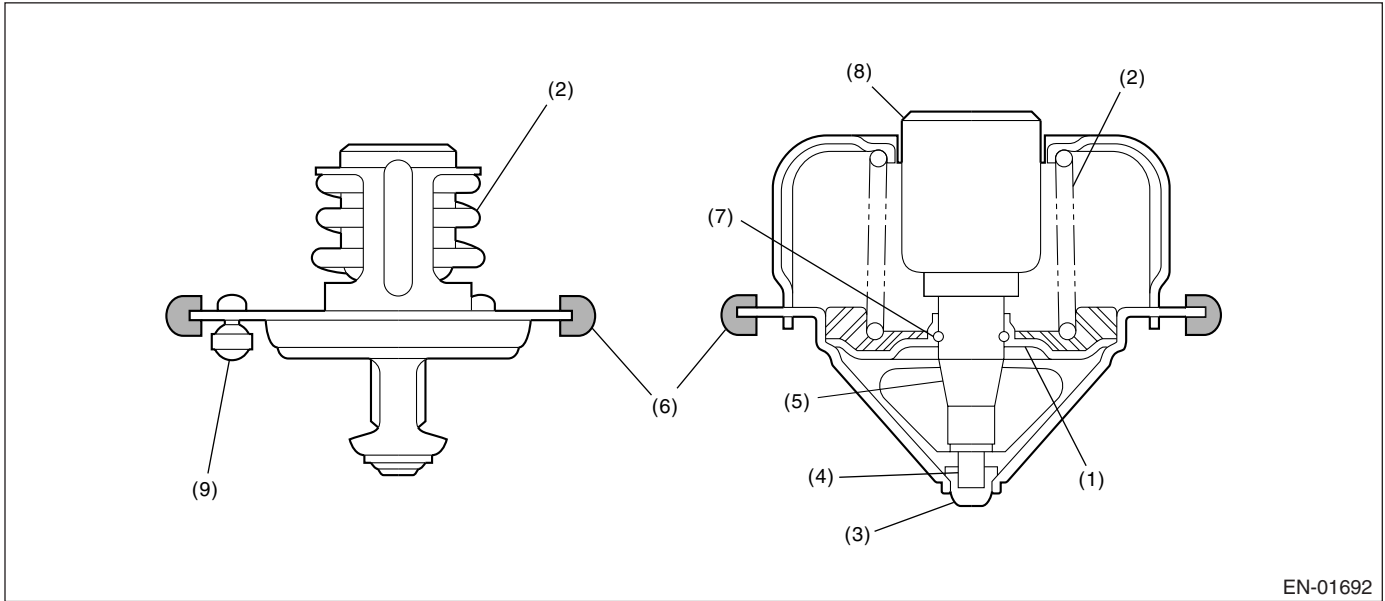

EN-01692

- |             |                    |                  |
|-------------|--------------------|------------------|
| (1) Valve   | (4) Piston         | (7) Stop ring    |
| (2) Spring  | (5) Guide          | (8) Wax element  |
| (3) Stopper | (6) Rubber packing | (9) Jiggle valve |

#### 3. ENABLE CONDITION

Secondary Parameters	Enable Conditions
None	

#### 4. GENERAL DRIVING CYCLE

Always perform the diagnosis continuously.

# Diagnostic Trouble Code (DTC) Detecting Criteria

GENERAL DESCRIPTION

## 5. DIAGNOSTIC METHOD

### • Abnormality Judgment

Judge NG when the continuous time of completing the malfunction criteria below becomes more than 30 seconds.

### Judgment Value

Malfunction Criteria	Threshold Value
Battery voltage	$\geq 10.9$ V
Engine coolant temperature at engine starting	$< 55^{\circ}\text{C}$ ( $131^{\circ}\text{F}$ )
Engine coolant temperature	$< 75^{\circ}\text{C}$ ( $167^{\circ}\text{F}$ )
(Estimated – measured) coolant temperature	$> 30^{\circ}\text{C}$ ( $54^{\circ}\text{F}$ )
Vehicle speed	$\geq 30$ km/h ( $18.6$ MPH)
Estimated engine coolant temperature	$\geq 75^{\circ}\text{C}$ ( $167^{\circ}\text{F}$ )
Estimated ambient temperature	$\geq -7^{\circ}\text{C}$ ( $19^{\circ}\text{F}$ )

**Time Needed for Diagnosis:** Not fixed.

**Malfunction Indicator Light Illumination:** Illuminates when malfunction occurs in 2 continuous driving cycles.

### • Normality Judgment

Judge OK and clear the NG when the malfunction criteria below are completed.

### Judgment Value

Malfunction Criteria	Threshold Value
Battery voltage	$\geq 10.9$ V
Engine coolant temperature at engine starting	$< 55^{\circ}\text{C}$ ( $131^{\circ}\text{F}$ )
Engine coolant temperature	$\geq 75^{\circ}\text{C}$ ( $167^{\circ}\text{F}$ )
(Estimated – measured) coolant temperature	$\leq 30^{\circ}\text{C}$ ( $54^{\circ}\text{F}$ )

## 6. DTC CLEAR CONDITION

- When the OK idling cycle was completed 40 times in a row
- When “Clear Memory” was performed

## 7. MALFUNCTION INDICATOR LIGHT CLEAR CONDITION

- When the OK driving cycle was completed 3 times in a row
- When “Clear Memory” was performed

## 8. FAIL SAFE

None

## 9. ECM OPERATION AT DTC SETTING

- Memorize the freeze frame data. (For test mode \$02)
- Memorize the diagnostic value and trouble standard value. (For test mode \$06)

# Diagnostic Trouble Code (DTC) Detecting Criteria

## GENERAL DESCRIPTION

### AB:DTC P0131 O<sub>2</sub> SENSOR CIRCUIT LOW VOLTAGE (BANK 1 SENSOR 1)

#### 1. OUTLINE OF DIAGNOSIS

Detect the open or short circuit of sensor.

Judge NG when the element impressed voltage is out of range, or the element current is out of range.

#### 2. COMPONENT DESCRIPTION

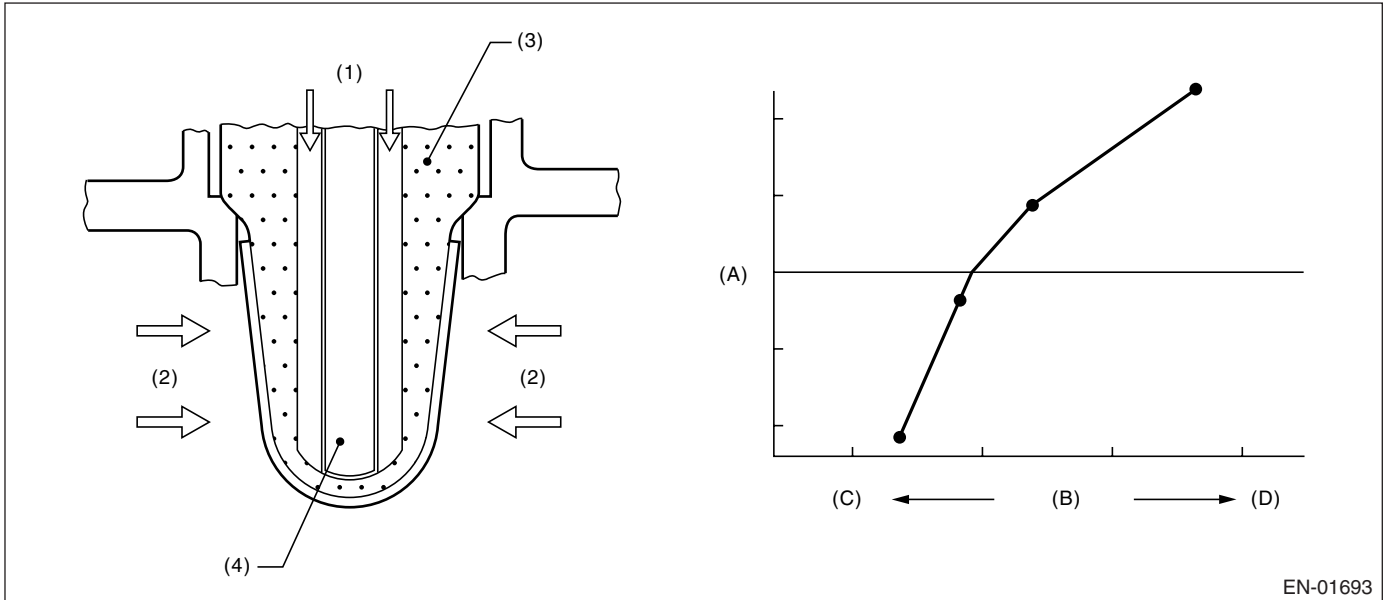

EN-01693

- |                      |                         |
|----------------------|-------------------------|
| (1) Atmosphere       | (A) Electromotive force |
| (2) Exhaust          | (B) Air fuel ratio      |
| (3) ZrO <sub>2</sub> | (C) Lean                |
| (4) Ceramic heater   | (D) Rich                |

#### 3. ENABLE CONDITION

Secondary Parameters	Enable Conditions
Battery voltage	≥ 10.9 V

#### 4. GENERAL DRIVING CYCLE

Always perform the diagnosis continuously.

#### 5. DIAGNOSTIC METHOD

Judge NG when the continuous time of completing any malfunction criteria below becomes more than 1 second.

##### Judgment Value

Malfunction Criteria	Threshold Value
Input voltage	< 1.8 V
Input current	< -0.005 A

**Time Needed for Diagnosis:** 1 second

**Malfunction Indicator Light Illumination:** Illuminates as soon as the malfunction occurs.

#### 6. DTC CLEAR CONDITION

- When the OK idling cycle was completed 40 times in a row
- When "Clear Memory" was performed

# Diagnostic Trouble Code (DTC) Detecting Criteria

GENERAL DESCRIPTION

## 7. MALFUNCTION INDICATOR LIGHT CLEAR CONDITION

- When the OK driving cycle was completed 3 times in a row
- When "Clear Memory" was performed

## 8. FAIL SAFE

- Front oxygen (A/F) sensor heater control: Not allowed to turned on the heater.
- A/F main learning: Not allowed to calculate the A/F main learning compensation factor.
- A/F sub learning: Not allowed to calculate the A/F sub learning compensation factor.
- Purge control: Not allowed to purge.

## 9. ECM OPERATION AT DTC SETTING

Memorize the freeze frame data. (For test mode \$02)

### AC:DTC P0132 O<sub>2</sub> SENSOR CIRCUIT HIGH VOLTAGE (BANK 1 SENSOR 1)

#### 1. OUTLINE OF DIAGNOSIS

Detect the open or short circuit of sensor.

Judge NG when the element impressed voltage is out of range, or the element current is out of range.

#### 2. COMPONENT DESCRIPTION

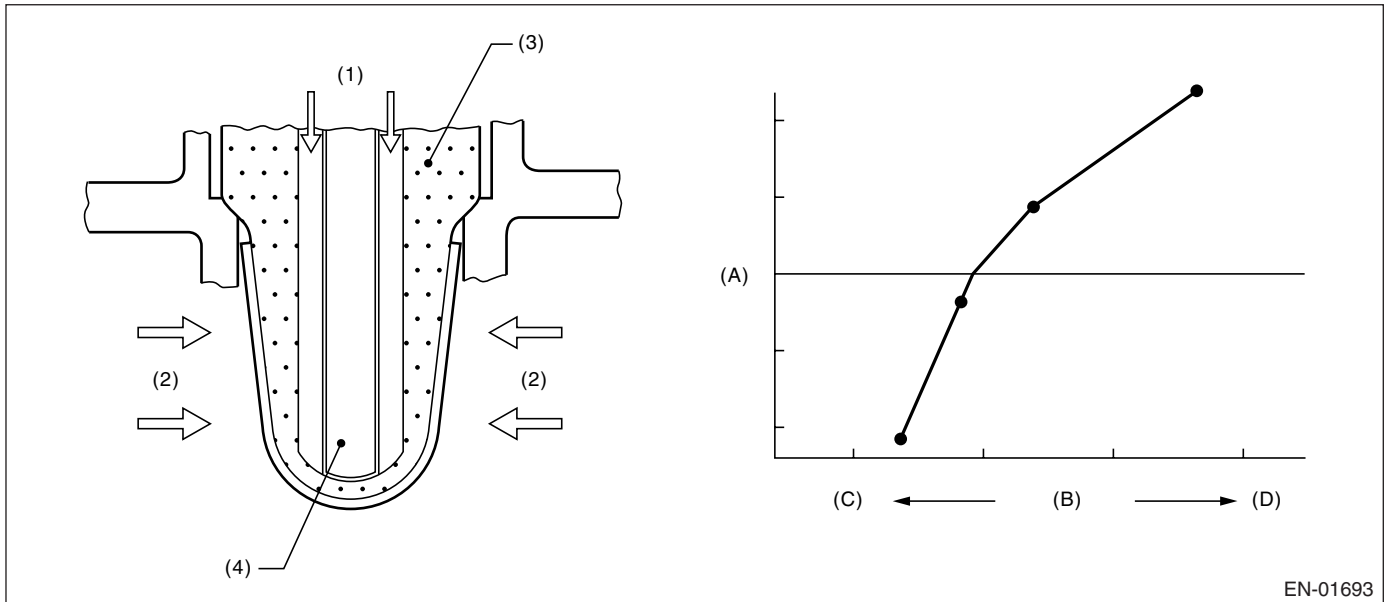

EN-01693

- |                      |                         |
|----------------------|-------------------------|
| (1) Atmosphere       | (A) Electromotive force |
| (2) Exhaust          | (B) Air fuel ratio      |
| (3) ZrO <sub>2</sub> | (C) Lean                |
| (4) Ceramic heater   | (D) Rich                |

#### 3. ENABLE CONDITION

Secondary Parameters	Enable Conditions
Battery voltage	≥ 10.9 V

#### 4. GENERAL DRIVING CYCLE

Always perform the diagnosis continuously.

# Diagnostic Trouble Code (DTC) Detecting Criteria

## GENERAL DESCRIPTION

---

### 5. DIAGNOSTIC METHOD

Judge NG when the continuous time of completing any malfunction criteria below becomes more than 1 second.

#### Judgment Value

Malfunction Criteria	Threshold Value
Input voltage	$\geq 3.8$ V
Input current	$\geq 0.005$ A

**Time Needed for Diagnosis:** 1 second

**Malfunction Indicator Light Illumination:** Illuminates as soon as the malfunction occurs.

### 6. DTC CLEAR CONDITION

- When the OK idling cycle was completed 40 times in a row
- When "Clear Memory" was performed

### 7. MALFUNCTION INDICATOR LIGHT CLEAR CONDITION

- When the OK driving cycle was completed 3 times in a row
- When "Clear Memory" was performed

### 8. FAIL SAFE

- Front oxygen (A/F) sensor heater control: Not allowed to turned on the heater.
- A/F main learning: Not allowed to calculate the A/F main learning compensation factor.
- A/F sub learning: Not allowed to calculate the A/F sub learning compensation factor.
- Purge control: Not allowed to purge.

### 9. ECM OPERATION AT DTC SETTING

Memorize the freeze frame data. (For test mode \$02)



# Diagnostic Trouble Code (DTC) Detecting Criteria

GENERAL DESCRIPTION

## AD:DTC P0133 O<sub>2</sub> SENSOR CIRCUIT SLOW RESPONSE (BANK 1 SENSOR 1)

### 1. OUTLINE OF DIAGNOSIS

Detect time-lag of front oxygen (A/F) sensor response. Front oxygen (A/F) sensor cover has some ventilation holes for exhaust gas. Clogged ventilation holes are diagnosed. When the holes are clogged, the A/F output variation becomes slow comparing with the actual A/F variation because oxygen which reaches the zirconia layer is insufficient. Therefore, if the cover has clogged holes, the rich to lean judgment in ECM is delayed when the change from rich to lean is caused. Judge NG when the actual A/F variation is slow comparing with the ECM control amount.

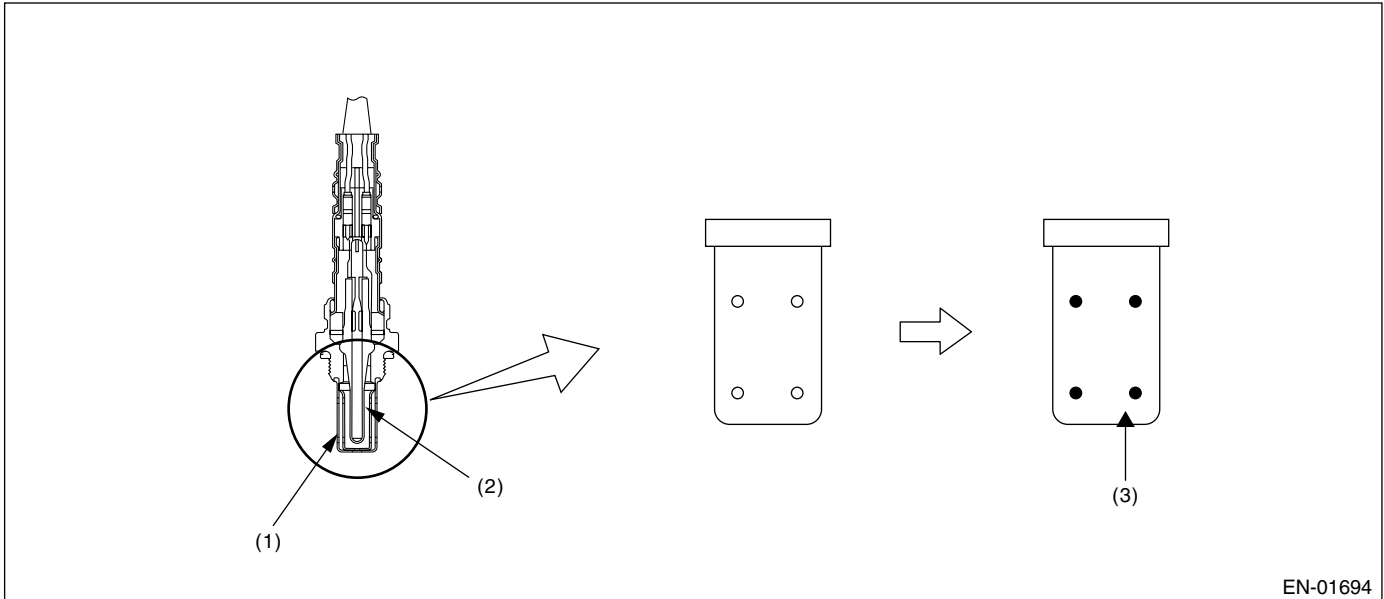

EN-01694

(1) Cover

(2) Zirconia

(3) Clogging

### 2. COMPONENT DESCRIPTION

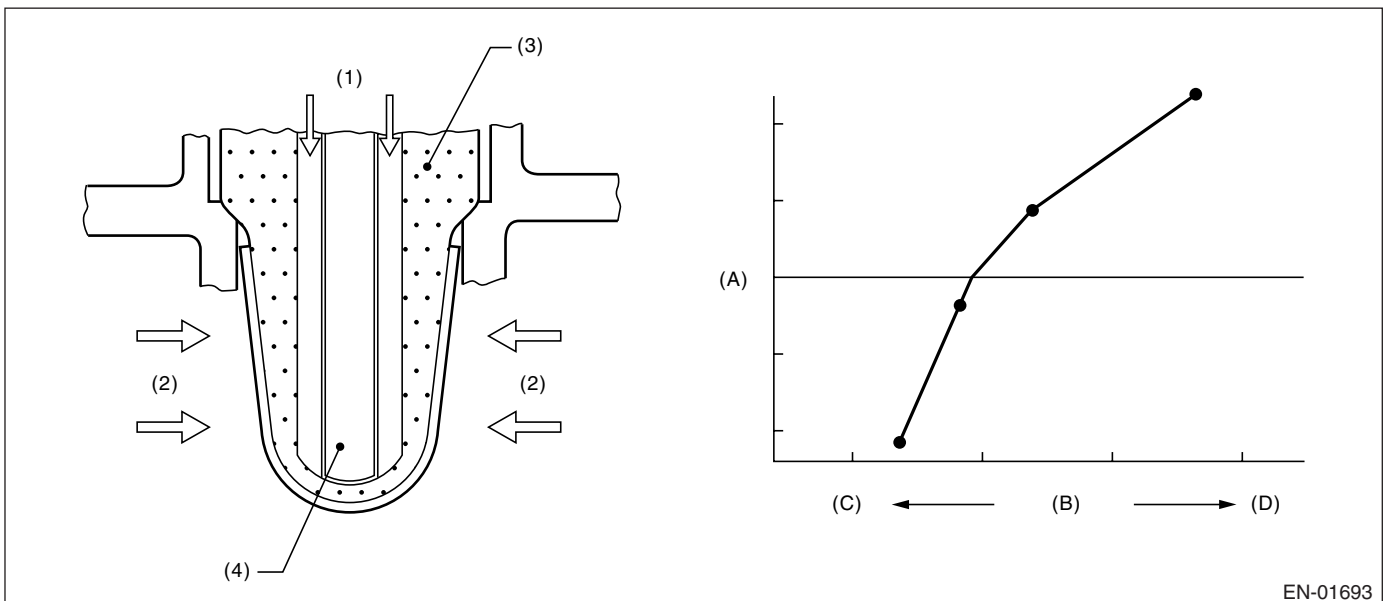

EN-01693

(1) Atmosphere

(2) Exhaust

(3) ZrO<sub>2</sub>

(4) Ceramic heater

(A) Electromotive force

(B) Air fuel ratio

(C) Lean

(D) Rich

# Diagnostic Trouble Code (DTC) Detecting Criteria

## GENERAL DESCRIPTION

### 3. ENABLE CONDITION

Secondary Parameters	Enable Conditions
All secondary parameter enable conditions	More than 1 second
Battery voltage	> 10.9 V
Atmospheric pressure	> 75.1 kPa (563 mmHg, 22.2 inHg)
Closed loop control with main feedback	Operating
Impedance of front oxygen (A/F) sensor	0 $\longleftrightarrow$ 50 $\Omega$
After engine starting	120 seconds or more
Engine coolant temperature	$\geq 75^{\circ}\text{C}$ ( $167^{\circ}\text{F}$ )
Engine speed	1,000 $\longleftrightarrow$ 3,200 rpm
Vehicle speed	10 $\longleftrightarrow$ 120 km/h (6.21 $\longleftrightarrow$ 74.6 MPH)
Amount of intake air	10 $\longleftrightarrow$ 40 g (0.35 $\longleftrightarrow$ 1.41 oz)/s
Engine load change during 0.5 engine rev.	$\leq 0.02$ g (0.001 oz)/rev
Learning value of EVAP conc. during purge	$\leq 0.2$
Total time of operating canister purge	20 seconds or more

### 4. GENERAL DRIVING CYCLE

Perform diagnosis only once at a constant speed of 10 to 120 km/h (6.21 to 74.6 MPH) in 120 seconds after starting the engine.

### 5. DIAGNOSTIC METHOD

Integrate the difference of  $f_{af}$  in every 128 milliseconds and difference of  $\lambda$  value.

After integrate 210 seconds, calculate the diagnosis value.

Judge NG when the malfunction criteria below are completed. Judge OK and clear NG when the malfunction criteria below are not completed.

#### Judgment Value

Malfunction Criteria	Threshold Value
$\text{para}fca = \text{td}2f_{af}/\text{td}2l_{md}$ where, $\text{td}2f_{af}(N) = \text{td}2f_{af}(n-1) +  d2f_{af}(n) $ $\text{td}2l_{md}(N) = \text{td}2l_{md}(n-1) +  d2l_{md}(n) $ add up for a total of 210 seconds $d2f_{af}(n) = (f_{af}(n) - f_{af}(n-1)) - (f_{af}(n-1) - f_{af}(n-2))$ $d2l_{md}(n) = (l_{md}(n) - l_{md}(n-1)) - (l_{md}(n-1) - l_{md}(n-2))$ $f_{af} = \text{main feedback compensation coefficient every 128 milliseconds}$ $l_{md} = \text{output lambda every 128 milliseconds}$	$\geq 0.44$

**Time Needed for Diagnosis:** 210 seconds

**Malfunction Indicator Light Illumination:** Illuminates when malfunction occurs in 2 continuous driving cycles.

### 6. DTC CLEAR CONDITION

- When the OK idling cycle was completed 40 times in a row
- When "Clear Memory" was performed

# Diagnostic Trouble Code (DTC) Detecting Criteria

GENERAL DESCRIPTION

## 7. MALFUNCTION INDICATOR LIGHT CLEAR CONDITION

- When the OK driving cycle was completed 3 times in a row
- When "Clear Memory" was performed

## 8. FAIL SAFE

- Front oxygen (A/F) sensor main learning correction: Not allowed to calculate.
- A/F sub learning correction: Not allowed to calculate.
- Purge control: Not allowed to purge.

## 9. ECM OPERATION AT DTC SETTING

- Memorize the freeze frame data. (For test mode \$02)
- Memorize the diagnostic value and trouble standard value. (For test mode \$06)

## AE:DTC P0134 O<sub>2</sub> SENSOR CIRCUIT NO ACTIVITY DETECTED (BANK 1 SENSOR 1)

### 1. OUTLINE OF DIAGNOSIS

Detect the open circuit of sensor.  
Judge NG when the element impedance is large.

### 2. COMPONENT DESCRIPTION

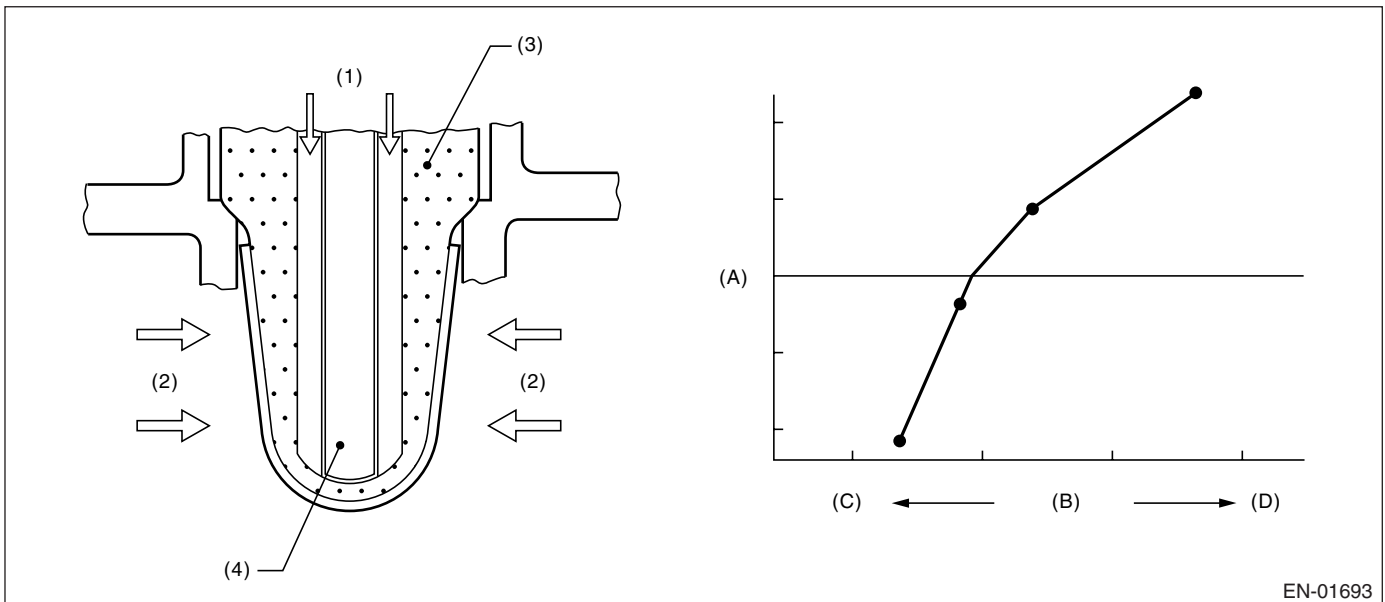

EN-01693

- |                      |                         |
|----------------------|-------------------------|
| (1) Atmosphere       | (A) Electromotive force |
| (2) Exhaust          | (B) Air fuel ratio      |
| (3) ZrO <sub>2</sub> | (C) Lean                |
| (4) Ceramic heater   | (D) Rich                |

### 3. ENABLE CONDITION

Secondary Parameters	Enable Conditions
None	

### 4. GENERAL DRIVING CYCLE

Always perform the diagnosis continuously.

# Diagnostic Trouble Code (DTC) Detecting Criteria

## GENERAL DESCRIPTION

---

### 5. DIAGNOSTIC METHOD

Judge NG when the continuous time of completing the malfunction criteria below becomes more than 5 seconds.

#### Judgment Value

Malfunction Criteria	Threshold Value
Battery voltage	$\geq 10.9$ V
Time of heater duty $\geq 70\%$	$\geq 30$ seconds
Front lambda sensor impedance	$\geq 500$ $\Omega$

**Time Needed for Diagnosis:**5 seconds

**Malfunction Indicator Light Illumination:**Illuminates as soon as the malfunction occurs.

### 6. DTC CLEAR CONDITION

- When the OK idling cycle was completed 40 times in a row
- When "Clear Memory" was performed

### 7. MALFUNCTION INDICATOR LIGHT CLEAR CONDITION

- When the OK driving cycle was completed 3 times in a row
- When "Clear Memory" was performed

### 8. FAIL SAFE

- Front oxygen (A/F) sensor heater control: Not allowed to turned on the heater.
- A/F main learning: Not allowed to calculate the A/F main learning compensation factor.
- A/F sub learning: Not allowed to calculate the A/F sub learning compensation factor.
- Purge control: Not allowed to purge.

### 9. ECM OPERATION AT DTC SETTING

Memorize the freeze frame data. (For test mode \$02)

# Diagnostic Trouble Code (DTC) Detecting Criteria

GENERAL DESCRIPTION

## AF:DTC P0137 O<sub>2</sub> SENSOR CIRCUIT LOW VOLTAGE (BANK 1 SENSOR 2)

### 1. OUTLINE OF DIAGNOSIS

Detect the malfunction of oxygen sensor power distribution NG. Judge NG when the oxygen sensor voltage is abnormal with considering the operating conditions.

### 2. COMPONENT DESCRIPTION

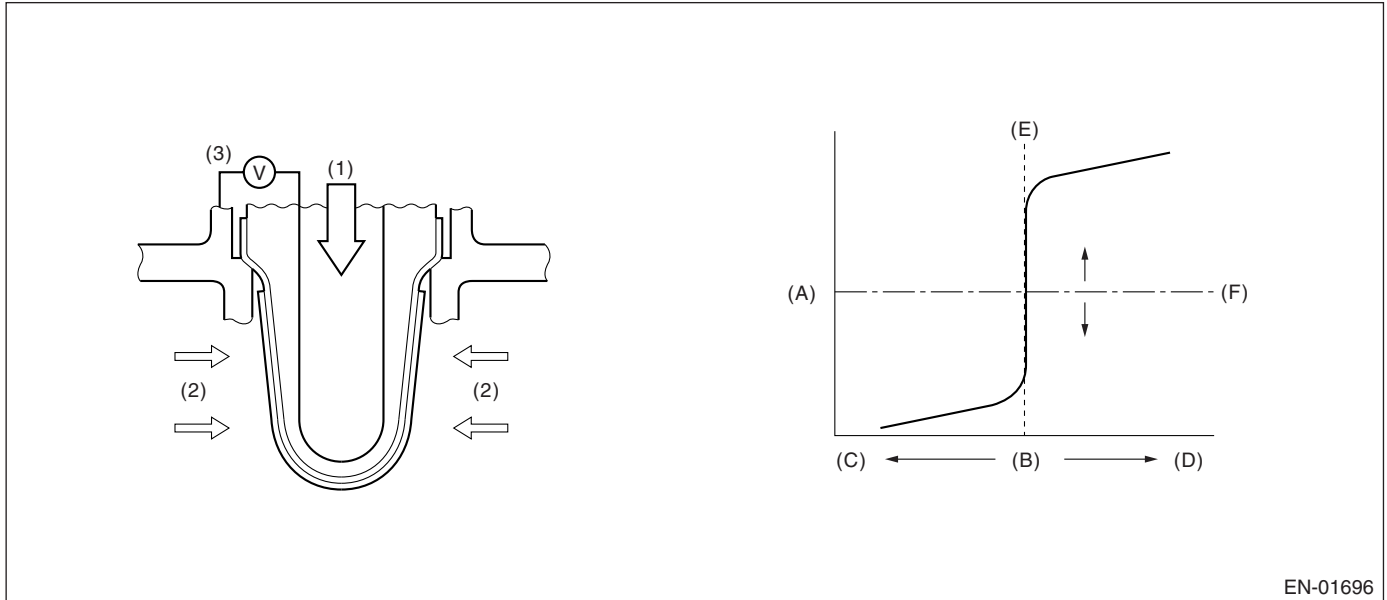

EN-01696

- (1) Atmosphere
- (2) Exhaust
- (3) Electromotive force

- (A) Electromotive force
- (B) Air fuel ratio
- (C) Rich

- (D) Lean
- (E) Theoretical air fuel ratio
- (F) Comparative voltage

# Diagnostic Trouble Code (DTC) Detecting Criteria

## GENERAL DESCRIPTION

### 3. ENABLE CONDITION

#### Abnormality Judgement

Secondary Parameters	Enable Conditions
High side	
Secondary air system	Not in operation
Closed loop control of oxygen sensor	In operation
Misfire detection during 200 engine revs.	< 5 times
Compensation factor for front oxygen (A/F) sensor	Not in limit value
Battery voltage	> 10.9 V
Low side 1	
Secondary air system	Not in operation
Closed loop control of oxygen sensor	In operation
Misfire detection during 200 engine revs.	< 5 times
Compensation factor for front oxygen (A/F) sensor	Not in limit value
Battery voltage	> 10.9 V
Amount of intake air	≥ 10 g (0.35 oz)/s
Low side 2	
Secondary air system	Not in operation
Closed loop control of oxygen sensor	In operation
Misfire detection during 200 engine revs.	< 5 times
Compensation factor for front oxygen (A/F) sensor	Not in limit value
Battery voltage	> 10.9 V
Amount of intake air	< 10 g (0.35 oz)/s
Continuous time of rear oxygen heater current	25 seconds or more
Low side 3	
Secondary air system	Not in operation
Closed loop control of oxygen sensor	In operation
Misfire detection during 200 engine revs.	< 5 times
Compensation factor for front oxygen (A/F) sensor	Not in limit value
Battery voltage	> 10.9 V
Amount of intake air	< 10 g (0.35 oz)/s
Continuous time of rear oxygen heater current	25 seconds or more
Fuel cut	Experienced

#### Normality Judgement

Secondary Parameters	Enable conditions
Secondary air system	No operation
Closed loop control of oxygen sensor	In operation
Misfire detection during 200 engine revs.	< 5 times
Compensation factor for front oxygen (A/F) sensor	Not in limit value
Battery voltage	> 10.9 V

### 4. GENERAL DRIVING CYCLE

Perform the diagnosis continuously after starting the engine at engine steady operation condition.

# Diagnostic Trouble Code (DTC) Detecting Criteria

GENERAL DESCRIPTION

## 5. DIAGNOSTIC METHOD

### • Abnormality Judgment

Judge NG when the continuous time of completing the malfunction criteria below becomes more than the time needed for diagnosis. Judge OK when the malfunction criteria below are not completed.

### Judgment Value

Malfunction Criteria	Threshold Value	DTC
High side Max. output voltage without continuity	$\geq 1,200$ mV	P0138
Low side Min. output voltage without continuity	$< 30$ mV	P0137

### Time Needed for Diagnosis:

High side: 2.5 seconds

Low side 1: 20 seconds

Low side 2: 40 seconds

Low side 3: Value of Map

### Map

Fuel shut-off time (sec.)	Time Needed for Diagnosis (sec.)
0	40
2	40
10	60

**Malfunction Indicator Light Illumination:** Illuminates when malfunction occurs in 2 continuous driving cycles.

## 6. DTC CLEAR CONDITION

- When the OK idling cycle was completed 40 times in a row
- When "Clear Memory" was performed

## 7. MALFUNCTION INDICATOR LIGHT CLEAR CONDITION

- When the OK driving cycle was completed 3 times in a row
- When "Clear Memory" was performed

## 8. FAIL SAFE

Sub feedback control: Not allowed

## 9. ECM OPERATION AT DTC SETTING

Memorize the freeze frame data. (For test mode \$02)

# Diagnostic Trouble Code (DTC) Detecting Criteria

## GENERAL DESCRIPTION

### AG:DTC P0138 O<sub>2</sub> SENSOR CIRCUIT HIGH VOLTAGE (BANK 1 SENSOR 2)

#### NOTE:

For the detection criteria, refer to DTC P0137. <Ref. to GD(H4SO)-53, DTC P0137 O<sub>2</sub> SENSOR CIRCUIT LOW VOLTAGE (BANK 1 SENSOR 2), Diagnostic Trouble Code (DTC) Detecting Criteria.>

### AH:DTC P0139 O<sub>2</sub> SENSOR CIRCUIT SLOW RESPONSE (BANK 1 SENSOR 2)

#### 1. OUTLINE OF DIAGNOSIS

Detect the slow response of rear oxygen sensor.

Judge NG when the Rich → Lean response diagnosis or Lean → Rich response diagnosis is NG and judge OK when both response diagnoses are OK.

[Rich → Lean diagnosis response]

(1) When the measured response time is larger than a threshold, since the A/F ratio is rich, the response time of the output change of O<sub>2</sub> sensor when changing from Rich to Lean is measured, and it judges with NG, and when small, it judges with OK.

(2) When O<sub>2</sub> sensor voltage at the time of a fuel shut-off in deceleration return is large (rich), it judges with NG.

[Lean → Rich diagnosis response]

(1) The response time of output change of O<sub>2</sub> sensor when an A/F ratio changes from Lean to Rich is measured, and it is referred to as NG when the measured response time is larger than a threshold.

(2) It is referred to as NG when O<sub>2</sub> sensor voltage after recovery of fuel shut-off in deceleration is small and still small.

#### • Diagnostic Method

Measure the response time of the output change of the oxygen sensor when the A/F ratio changes from rich to lean. And Judge NG when the measured response time is larger than the threshold value.

#### 2. COMPONENT DESCRIPTION

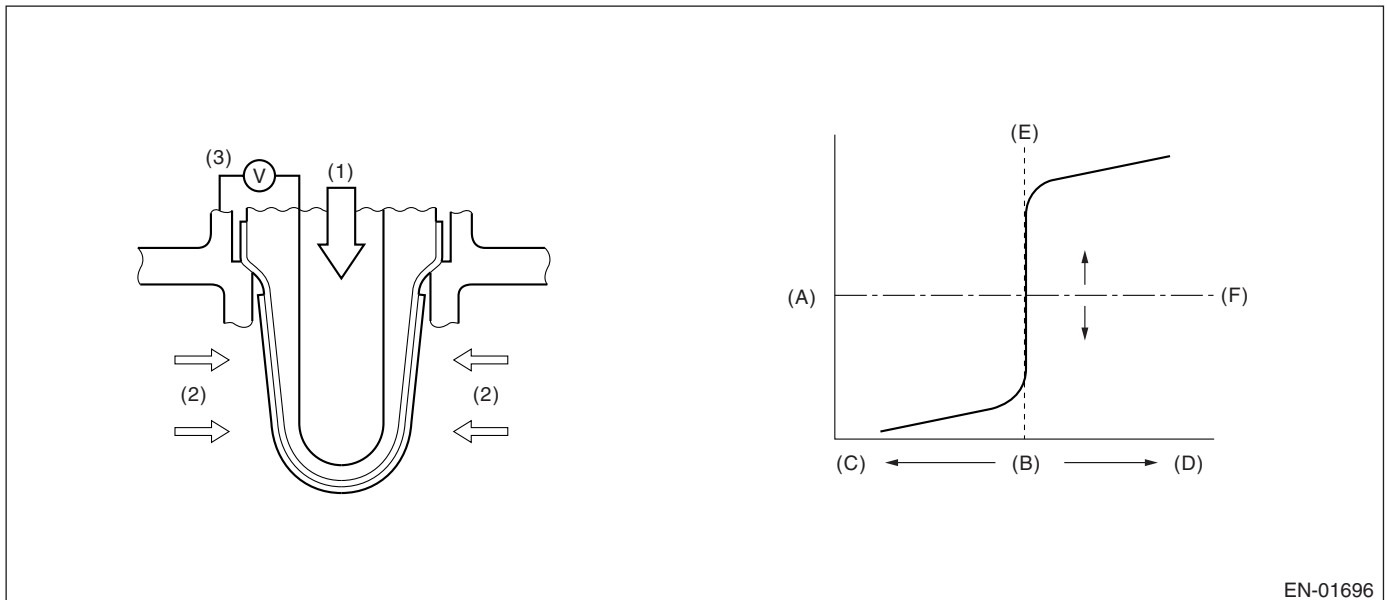

EN-01696

- (1) Atmosphere
- (2) Exhaust
- (3) Electromotive force

- (A) Electromotive force
- (B) Air fuel ratio
- (C) Rich

- (D) Lean
- (E) Theoretical air fuel ratio
- (F) Comparative voltage



# Diagnostic Trouble Code (DTC) Detecting Criteria

GENERAL DESCRIPTION

## 3. ENABLE CONDITION

- Rich → Lean response diagnosis

Secondary Parameters	Enable Conditions
Battery voltage	> 10.9 V
A/F sub feedback control condition	Completed
6 seconds or more fuel shut-off indecel. time	Experienced
After fuel cut	≥ 2 seconds
Accumulative time of rear oxygen heater current	≥ 60 seconds
Continuous time of rear oxygen heater current	≥ 30 seconds
Catalyst warm-up counter	≥ 9000

## 4. GENERAL DRIVING CYCLE

Perform the diagnosis only once when fuel shut-off in deceleration after rapid acceleration. (Pay attention to oxygen sensor voltage for the timing of deceleration.)

# Diagnostic Trouble Code (DTC) Detecting Criteria

## GENERAL DESCRIPTION

### 5. DIAGNOSTIC METHOD

When the oxygen sensor output voltage changes from 0.55 V (rich) to 0.25 V (lean), calculate the Min. value of response time regarded as judgment value while the output varies from 0.5 V to 0.3 V.

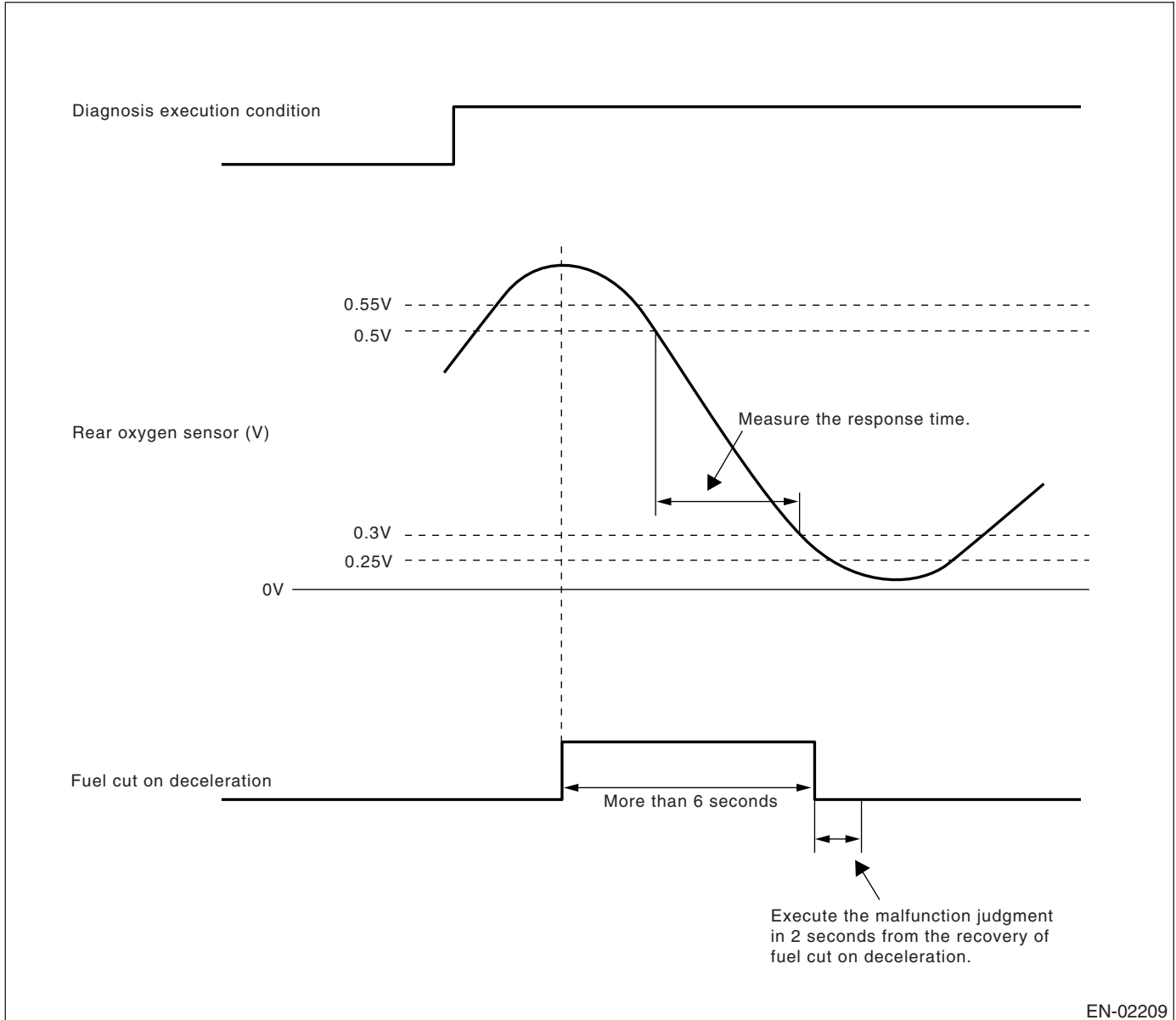

EN-02209

#### • Abnormality Judgment

(1) Judge NG when the judgment value is larger than the threshold value after fuel shut-off in deceleration. Response time (Diagnosis value) > Threshold value → Abnormal

#### NOTE:

Variation time of rear oxygen sensor output voltage is short during fuel shut-off in deceleration. Carry out the NG judgment only after the fuel shut-off in deceleration. As for OK judgment, without the condition of fuel shut-off in deceleration, judge OK if the value is below the threshold value.

Judge NG when the malfunction criteria below are completed in 2 seconds after the recovery of fuel shut-off in deceleration which requires 6 seconds or more.

(2) Judge NG when the O<sub>2</sub> sensor voltage after recovery of fuel shut-off in deceleration is large. Judge NG when fuel shut-off in deceleration is also long (6 sec. or more), and although carried out the fuel shut-off in deceleration cut return, when O<sub>2</sub> sensor voltage is large (more than 0.55V).

# Diagnostic Trouble Code (DTC) Detecting Criteria

GENERAL DESCRIPTION

## Judgment Value

Malfunction Criteria	Threshold Value
Shortest time change from rich (500 mV O <sub>2</sub> output) to lean (300 mV) if voltage reduces from 550 mV to 250 mV.	> 327 milliseconds
Time when more than 550 mV	> 2 seconds

**Time Needed for Diagnosis:** 1 time

**Malfunction Indicator Light Illumination:** Illuminates when malfunction occurs in 2 continuous driving cycles.

### • Normality Judgement

(1) Judge Normal when the response time (diagnostic value) is smaller than threshold (judgment value) when changing to lean since O<sub>2</sub> sensor voltage.

(2) A normal judging is not carried out.

## Judgment Value

Judge OK when the following standards value are completed.

Malfunction Criteria	Threshold Value
Change of the shortest time from rich (500 mV O <sub>2</sub> output), when voltage decreases from 550 mV to 250 mV to lean (300 mV).	≤ 327 milliseconds

## 6. DTC CLEAR CONDITION

- When the OK idling cycle was completed 40 times in a row
- When "Clear Memory" was performed

## 7. MALFUNCTION INDICATOR LIGHT CLEAR CONDITION

- When the OK driving cycle was completed 3 times in a row
- When "Clear Memory" was performed

## 8. FAIL SAFE

Sub feedback control: Not allowed

## 9. ECM OPERATION AT DTC SETTING

- Memorize the freeze frame data. (For test mode \$02)
- Memorize the diagnostic value and trouble standard value. (For test mode \$06)

## 10. ENABLE CONDITION

- Lean → Rich response diagnosis

Secondary Parameters	Enable Conditions
Battery voltage	> 10.9 V
A/F main feedback control condition	Completed
Fuel cut on deceleration ≥ 6 seconds	Experienced
After fuel cut	≥ 2 seconds

## 11. GENERAL DRIVING CYCLE

Perform the diagnosis only once when fuel shut-off in deceleration after rapid acceleration. (Pay attention to oxygen sensor voltage for the timing of deceleration.)

# Diagnostic Trouble Code (DTC) Detecting Criteria

## GENERAL DESCRIPTION

### 12. DIAGNOSTIC METHOD

When the oxygen sensor output voltage changes from 0.25 V (lean) to 0.55 V (rich), calculate the Min. value of response time regarded as judgment value while the output varies from 0.3 V to 0.5 V.

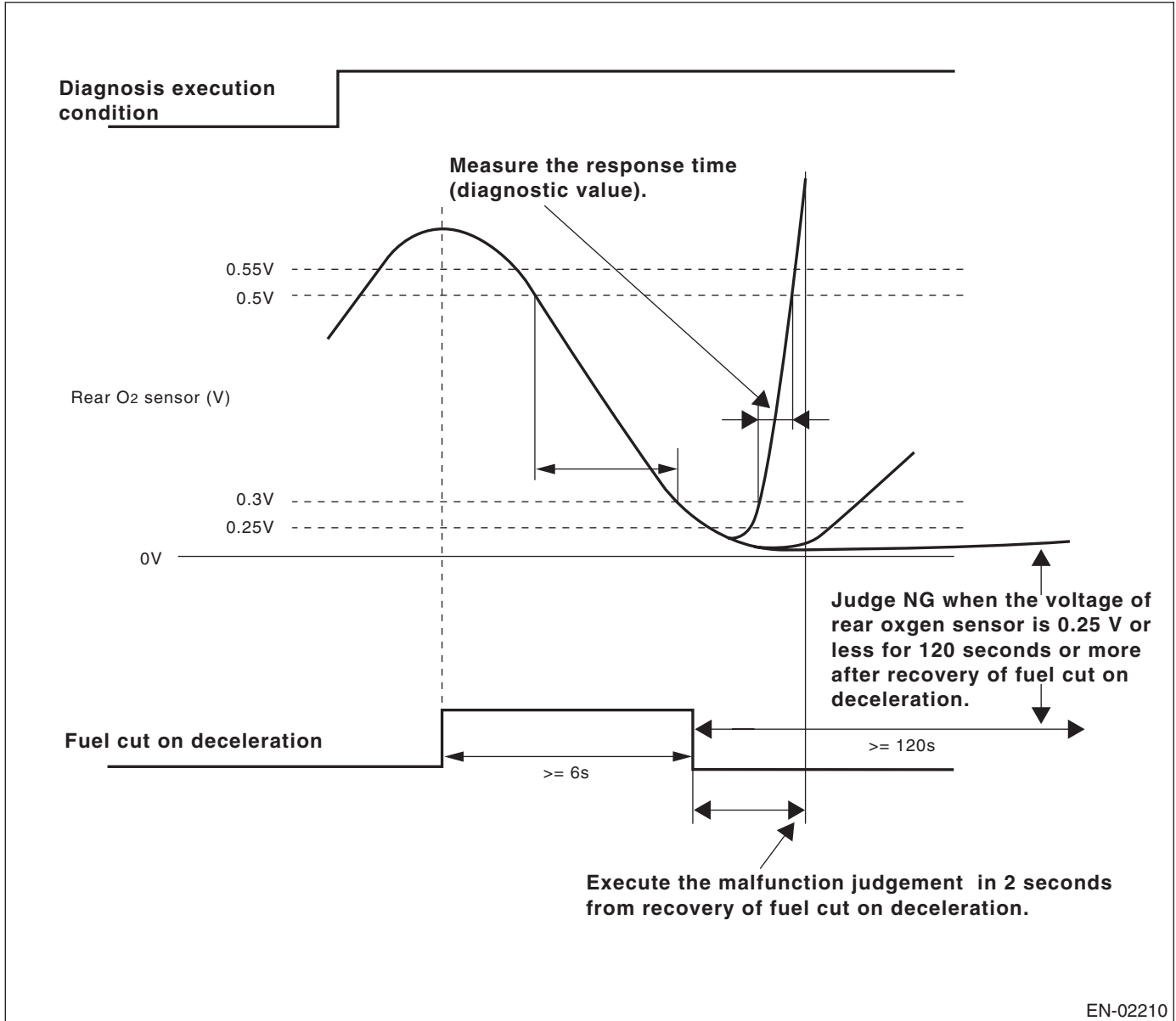

#### • Abnormality Judgment

(1) Judge NG when the judgment value is larger than the threshold value after recovery of fuel shut-off in deceleration.

Response time (Diagnosis value) > Threshold value → Abnormal

(2) Judge NG when the O<sub>2</sub> sensor voltage after recovery of fuel shut-off in deceleration is small.

#### Judgment Value

Malfunction Criteria	Threshold Value
Shortest time change from lean (300 mV O <sub>2</sub> output) to rich (500 mV) if voltage reduces from 500 mV to 250 mV.	> 2 seconds
Time when less than 250 mV	> 120 seconds

**Time Needed for Diagnosis:** 1 time

**Malfunction Indicator Light Illumination:** Illuminates when malfunction occurs in 2 continuous driving cycles.

# Diagnostic Trouble Code (DTC) Detecting Criteria

GENERAL DESCRIPTION

## • Normality Judgement

(1) Judge Normal when the response time (diagnostic value) is smaller than threshold (judgment value) when changing to lean since O<sub>2</sub> sensor voltage.

Response Time (diagnosis value) ≤ Threshold value → Normal

(2) A normal judging is not carried out.

## Judgment Value

Judge OK when the following standards value are completed.

Malfunction Criteria	Threshold Value
Change of the shortest time from rich (300 mV O <sub>2</sub> output), when voltage decreases from 550 mV to 250 mV to lean (500 mV).	≤ 2 seconds

## 13.DTC CLEAR CONDITION

- When the OK idling cycle was completed 40 times in a row
- When "Clear Memory" was performed

## 14.MALFUNCTION INDICATOR LIGHT CLEAR CONDITION

- When the OK driving cycle was completed 3 times in a row
- When "Clear Memory" was performed

## 15.FAIL SAFE

Sub feedback control: Not allowed

## 16.ECM OPERATION AT DTC SETTING

- Memorize the freeze frame data. (For test mode \$02)
- Memorize the diagnostic value and trouble standard value. (For test mode \$06)

# Diagnostic Trouble Code (DTC) Detecting Criteria

## GENERAL DESCRIPTION

### AI: DTC P0140 O<sub>2</sub> SENSOR CIRCUIT NO ACTIVITY DETECTED (BANK1 SENSOR 2)

#### 1. OUTLINE OF DIAGNOSIS

Detect the malfunction of rear oxygen sensor output property.

Judge Low side NG when the rear oxygen sensor voltage indicates low, otherwise, judge High side NG when the rear oxygen sensor voltage indicates high, in spite of the driving condition that the voltage might move, by referring to the driving condition such as amount of intake air, coolant temperature, main feedback control, fuel shut-off in deceleration, etc.

Judge rear oxygen sensor property NG when the Low side or High side becomes NG.

#### 2. ENABLE CONDITION

Secondary Parameters	Enable Conditions
Engine coolant temperature	≥ 75°C (167°F)
Target output voltage of rear oxygen sensor	≥ 0.6 V
Amount of intake air	10 g (0.35 oz)/sec. or more
Battery voltage	> 10.9 V
Closed loop with oxygen sensor	In operation
Misfire detection during 200 engine revs.	5 times or less
Compensation factor for front oxygen (A/F) sensor	Not in limit value
5 seconds or more fuel shut-off in decel.	Experienced

#### 3. GENERAL DRIVING CYCLE

Perform the diagnosis once after warming-up the engine.

#### 4. DIAGNOSTIC METHOD

##### • Abnormality Judgment

Judge NG when any of the malfunction criteria below are completed.

##### Judgment Value

Malfunction Criteria	Threshold Value
Low side diagnosis of max. output voltage	< 0.55 V
High side diagnosis of min. output voltage	> 0.25 V

**Time Needed for Diagnosis:**200 second

**Malfunction Indicator Light Illumination:**Detect when malfunction occurs in 2 continuous driving cycles.

##### • Normality Judgment

Judge OK when the malfunction criteria below are completed.

##### Judgment Value

Malfunction Criteria	Threshold Value
Low side diagnosis of max. output voltage	≥ 0.55 V
High side diagnosis of min. output voltage	≤ 0.25 V

#### 5. DTC CLEAR CONDITION

- When the OK idling cycle was completed 40 times in a row
- When "Clear Memory" was performed

# Diagnostic Trouble Code (DTC) Detecting Criteria

GENERAL DESCRIPTION

## 6. MALFUNCTION INDICATOR LIGHT CLEAR CONDITION

- When the OK driving cycle was completed 3 times in a row
- When "Clear Memory" was performed

## 7. FAIL SAFE

Sub feedback control: Not allowed

## 8. ECM OPERATION AT DTC SETTING

Memorize the freeze frame data. (For test mode \$02)

## AJ:DTC P0171 SYSTEM TOO LEAN (BANK 1)

### 1. OUTLINE OF DIAGNOSIS

Detect the fuel system malfunction by the amount of main feedback control.

#### • Diagnostic Method

Fuel system is diagnosed by comparing the target air fuel ratio calculated by ECM with the actual air fuel ratio measured by sensor.

### 2. ENABLE CONDITION

- Lean side

Secondary Parameters	Enable Conditions
A/F main learning system	In operation
Engine coolant temperature	$\geq 75^{\circ}\text{C}$ ( $167^{\circ}\text{F}$ )
Intake air amount	$\geq$ Map 5
Intake air change during 0.5 engine rev.	$\leq 0.02$ g (0.001 oz)/rev

Map 5

Engine speed (rpm)	idle	650	1000	1500	2000	2500	3000	3500	4000	4500
Measured value (g (oz)/rev)	NA	0.203 (0.0072)	0.183 (0.0065)	0.155 (0.0055)	0.149 (0.0053)	0.157 (0.0055)	0.162 (0.0057)	0.18 (0.0063)	0.193 (0.0068)	0.205 (0.0072)

### 3. GENERAL DRIVING CYCLE

Perform the diagnosis continuously at engine idling after warm-up or a constant speed.

### 4. DIAGNOSTIC METHOD

#### • Abnormality Judgment

Judge that the fuel system malfunction occurs when the continuous time of completing the malfunction criteria below becomes more than 50 seconds by comparing the diagnosed value (fsobd) with threshold value.

#### Judgment Value

Malfunction Criteria	Threshold Value
$\text{fsobd} = (\text{sglmd} - \text{tglm da}) + \text{faf} + \text{flaf}$ where, sglmd = measured lambda tglm da = target lambda  faf = main feedback compensation coefficient every 64 milliseconds flaf = main feedback learning compensation coefficient	$\geq \text{fsobdL1}$ See Map 4  fsobdL1 = lean side threshold value of fsobd

# Diagnostic Trouble Code (DTC) Detecting Criteria

## GENERAL DESCRIPTION

---

Map 4 Threshold value for fuel system malfunction criteria

Amount of air [g(oz)/s]	0 (0)	3.2 (0.113)	6.4 (0.226)	9.6 (0.339)	12.8 (0.451)	16 (0.564)	19.2 (0.677)
fsobdL1 (%)	40	40	33.2	26.5	26.5	26.5	26.5

**Time Needed for Diagnosis:** 10 seconds × 5 times

**Malfunction Indicator Light Illumination:** Illuminates when malfunction occurs in 2 continuous driving cycles.

### • Normality Judgment

Judge OK when the continuous time of completing the malfunction criteria below becomes more than 10 seconds.

### Judgment Value

Malfunction Criteria	Threshold Value
$fsobd = (sglmd - tglmda) + faf + flaf$	< 19%

## 5. DTC CLEAR CONDITION

- When the OK idling cycle was completed 40 times in a row
- When "Clear Memory" was performed

## 6. MALFUNCTION INDICATOR LIGHT CLEAR CONDITION

- When OK with similar drive in 3 driving cycles.
- When "Clear Memory" was performed

## 7. FAIL SAFE

None

## 8. ECM OPERATION AT DTC SETTING

Memorize the freeze frame data. (For test mode \$02)



# Diagnostic Trouble Code (DTC) Detecting Criteria

GENERAL DESCRIPTION

## AK:DTC P0172 SYSTEM TOO RICH (BANK 1)

### 1. OUTLINE OF DIAGNOSIS

Detect the fuel system malfunction by the amount of main feedback control.

#### • Diagnostic Method

Fuel system is diagnosed by comparing the target air fuel ratio calculated by ECM with the actual air fuel ratio measured by sensor.

### 2. ENABLE CONDITION

Secondary Parameters	Enable Conditions
A/F main learning system	In operation
Engine coolant temperature	≥ 75°C (167°F)
Intake air amount	≥ Map 5
Intake air change during 0.5 engine rev.	≤ 0.02 g (0.001 oz)/rev
Learning value of EVAP conc. during purge	< 0.1
Cumulative time of canister purge after engine start	20 seconds or more
Continuous period after canister purge starting	30 seconds or more

Map 5

Engine speed (rpm)	idle	650	1000	1500	2000	2500	3000	3500	4000	4500
Measured value (g (oz)/rev)	NA	0.203 (0.0072)	0.183 (0.0065)	0.155 (0.0055)	0.149 (0.0053)	0.157 (0.0055)	0.162 (0.0057)	0.18 (0.0063)	0.193 (0.0068)	0.205 (0.0072)

### 3. GENERAL DRIVING CYCLE

Perform the diagnosis continuously at engine idling after warm-up or a constant speed.

### 4. DIAGNOSTIC METHOD

#### • Abnormality Judgment

Judge that the fuel system malfunction occurs when the continuous time of completing the malfunction criteria below becomes more than 50 seconds by comparing the diagnosed value (fsobd) with threshold value.

#### Judgment Value

Malfunction Criteria	Threshold Value
$fsobd = (sglmd - tglmda) + faf + flaf$ where, sglmd = measured lambda  tglmda = target lambda faf = main feedback compensation coefficient every 64 milliseconds flaf = main feedback learning compensation coefficient	$\leq fsobdR1$ See Map 4 fsobdR1 = rich side threshold value of fsobd

Map 4 Threshold value for fuel system malfunction criteria

Amount of air [g(oz)/s]	0 (0)	3.2 (0.113)	6.4 (0.226)	9.6 (0.339)	12.8 (0.451)	11.7 (0.413)	19.2 (0.677)
fsobdR1 (%)	-40	-40	-33.2	-26.5	-26.5	-26.5	-26.5

**Time Needed for Diagnosis:** 10 seconds × 5 times

**Malfunction Indicator Light Illumination:** Illuminates when malfunction occurs in 2 continuous driving cycles.

# Diagnostic Trouble Code (DTC) Detecting Criteria

## GENERAL DESCRIPTION

---

### • Normality Judgment

Judge OK when the continuous time of completing the malfunction criteria below becomes more than 10 seconds.

### Judgment Value

Malfunction Criteria	Threshold Value
$fsobd = (sglmd - tglmda) + faf + flaf$	$\geq -20\%$

### 5. DTC CLEAR CONDITION

- When the OK idling cycle was completed 40 times in a row
- When "Clear Memory" was performed

### 6. MALFUNCTION INDICATOR LIGHT CLEAR CONDITION

- When OK with similar drive in 3 drive cycles.
- When "Clear Memory" was performed

### 7. FAIL SAFE

Purge control solenoid valve control: Not allowed to purge.

### 8. ECM OPERATION AT DTC SETTING

Memorize the freeze frame data. (For test mode \$02)

# Diagnostic Trouble Code (DTC) Detecting Criteria

GENERAL DESCRIPTION

## AL:DTC P0181 FUEL TEMPERATURE SENSOR "A" CIRCUIT RANGE/PERFORMANCE

### 1. OUTLINE OF DIAGNOSIS

Detect the malfunction of fuel temperature sensor output property. Perform the diagnosis in two methods; namely, drift diagnosis and stuck diagnosis. Judge NG when either of them results in NG, and judge OK when both of them result in OK.

#### • Drift Diagnosis

Normally fuel temperature is lower than engine coolant temperature. When the fuel temperature becomes higher than the engine coolant temperature, the range is considered to be shifted, and make an NG judgment.

### 2. COMPONENT DESCRIPTION

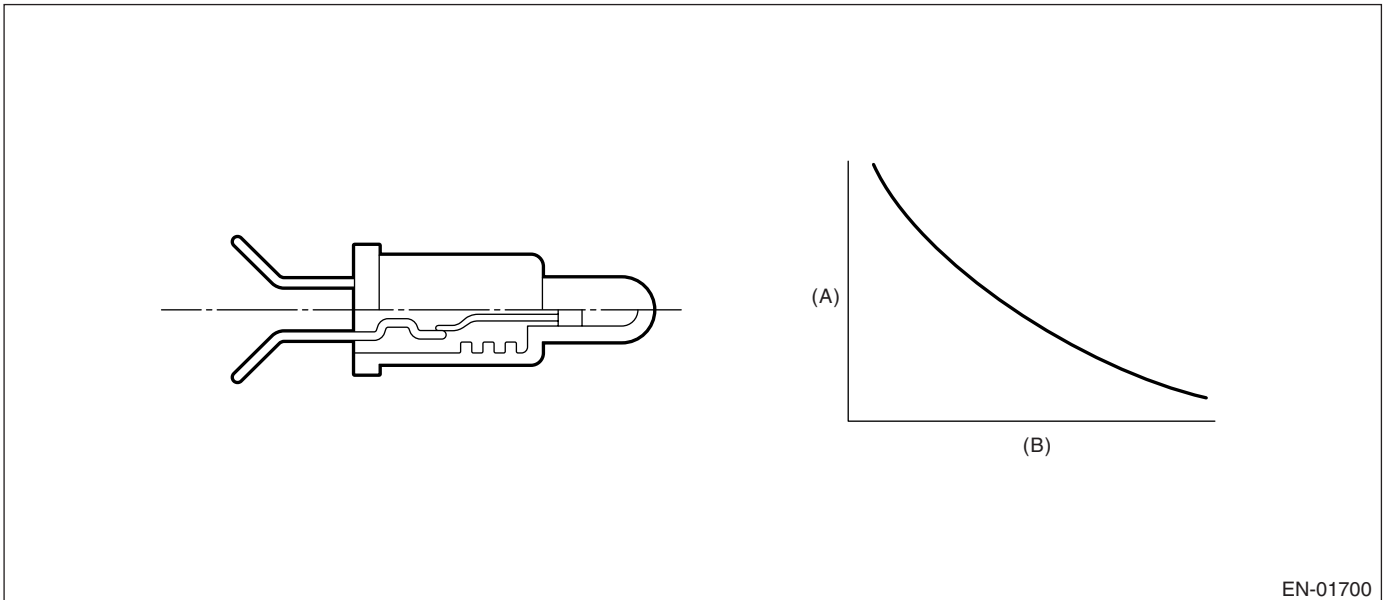

(A) Resistance value ( $\Omega$ )

(B) Fuel temperature  $^{\circ}\text{C}$  ( $^{\circ}\text{F}$ )

### 3. ENABLE CONDITION

Secondary Parameters	Enable Conditions
None	

### 4. GENERAL DRIVING CYCLE

Always perform the diagnosis continuously.

# Diagnostic Trouble Code (DTC) Detecting Criteria

## GENERAL DESCRIPTION

---

### 5. DIAGNOSTIC METHOD

#### • Abnormality Judgment

Judge NG when the continuous time of completing the malfunction criteria below becomes more than 120 seconds.

#### Judgment Value

Malfunction Criteria	Threshold Value
Fuel level	$\geq 9.0 \ell$ (2.38 US gal, 1.98 Imp gal)
After engine starting	20 seconds or more
Engine coolant temperature – engine coolant temperature at engine starting	$> 10^{\circ}\text{C}$ (18°F)
Fuel temperature – engine coolant temperature	$\geq 10^{\circ}\text{C}$ (18°F)
Battery voltage	$> 10.9 \text{ V}$

**Time Needed for Diagnosis:** 120 seconds

**Malfunction Indicator Light Illumination:** Illuminates when malfunction occurs in 2 continuous driving cycles.

#### • Normality Judgment

Judge OK when the malfunction criteria below are completed.

#### Judgment Value

Malfunction Criteria	Threshold Value
Fuel level	$\geq 9.0 \ell$ (2.38 US gal, 1.98 Imp gal)
After engine starting	20 seconds or more
Engine coolant temperature – engine coolant temperature at engine starting	$> 10^{\circ}\text{C}$ (18°F)
Fuel temperature – engine coolant temperature	$< 10^{\circ}\text{C}$ (18°F)
Engine coolant temperature	$< 75^{\circ}\text{C}$ (167°F)
Battery voltage	$> 10.9 \text{ V}$

#### • Stuck Diagnosis

If the fuel temperature which might rise along with the engine idling (the cumulative amount of intake air after engine starting is large) does not increase, the engine is considered to be stuck and make an NG judgment.

### 6. ENABLE CONDITION

Secondary Parameters	Enable Conditions
After engine starting	20 seconds or more
Battery voltage	$> 10.9 \text{ V}$

### 7. GENERAL DRIVING CYCLE

Perform the diagnosis continuously in 20 seconds or more after starting the engine.

# Diagnostic Trouble Code (DTC) Detecting Criteria

GENERAL DESCRIPTION

## 8. DIAGNOSTIC METHOD

### • Abnormality Judgment

Judge NG when the malfunction criteria below are completed.

#### Judgment Value

Malfunction Criteria	Threshold Value
Accumulated amount of intake air	≥ 551 kg (1,215 lb)
Fuel temperature difference between Max. and Min.	< 2°C (3.6°F)

**Time Needed for Diagnosis:**To be determined.

**Malfunction Indicator Light Illumination:**Illuminates when malfunction occurs in 2 continuous driving cycles.

### • Normality Judgment

Judge OK when the malfunction criteria below are completed.

#### Judgment Value

Malfunction Criteria	Threshold Value
Accumulated amount of intake air	≥ 551 kg (1,215 lb)
Fuel temperature difference between Max. and Min.	≥ 2°C (3.6°F)

## 9. DTC CLEAR CONDITION

- When the OK idling cycle was completed 40 times in a row
- When "Clear Memory" was performed

## 10.MALFUNCTION INDICATOR LIGHT CLEAR CONDITION

- When the OK driving cycle was completed 3 times in a row
- When "Clear Memory" was performed

## 11.FAIL SAFE

None

## 12.ECM OPERATION AT DTC SETTING

Memorize the freeze frame data. (For test mode \$02)

# Diagnostic Trouble Code (DTC) Detecting Criteria

## GENERAL DESCRIPTION

### AM:DTC P0182 FUEL TEMPERATURE SENSOR “A” CIRCUIT LOW INPUT

#### 1. OUTLINE OF DIAGNOSIS

Detect the open or short circuit of fuel temperature sensor. Judge NG when out of the standard value.

#### 2. COMPONENT DESCRIPTION

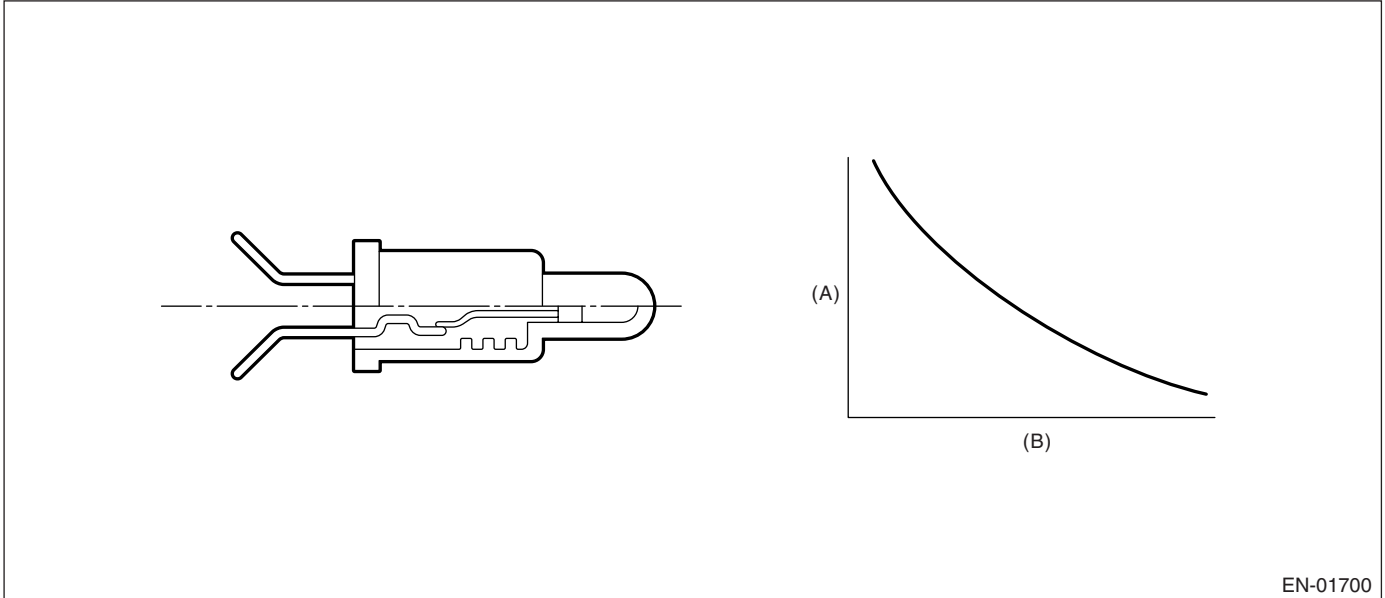

(A) Resistance value ( $\Omega$ )

(B) Fuel temperature °C (°F)

#### 3. ENABLE CONDITION

Secondary Parameters	Enable Conditions
None	

#### 4. GENERAL DRIVING CYCLE

Always perform the diagnosis continuously.

#### 5. DIAGNOSTIC METHOD

##### • Abnormality Judgment

Judge NG when the continuous time of completing the malfunction criteria below becomes more than 2.5 seconds.

##### Judgment Value

Malfunction Criteria	Threshold Value
Output voltage	< 0.166 V
Battery voltage	$\geq$ 10.9 V

**Time Needed for Diagnosis:**2.5 seconds

**Malfunction Indicator Light Illumination:**Illuminates as soon as the malfunction occurs.

##### • Normality Judgment

Judge OK when the cumulative time until completing the malfunction criteria below becomes more than 2.5 seconds.

##### Judgment Value

Malfunction Criteria	Threshold Value
Output voltage	$\geq$ 0.166 V
Battery voltage	$\geq$ 10.9 V

# Diagnostic Trouble Code (DTC) Detecting Criteria

GENERAL DESCRIPTION

## 6. DTC CLEAR CONDITION

- When the OK idling cycle was completed 40 times in a row
- When "Clear Memory" was performed

## 7. MALFUNCTION INDICATOR LIGHT CLEAR CONDITION

- When the OK driving cycle was completed 3 times in a row
- When "Clear Memory" was performed

## 8. FAIL SAFE

None

## 9. ECM OPERATION AT DTC SETTING

Memorize the freeze frame data. (For test mode \$02)

## AN:DTC P0183 FUEL TEMPERATURE SENSOR "A" CIRCUIT HIGH INPUT

### 1. OUTLINE OF DIAGNOSIS

Detect the open or short circuit of fuel temperature sensor. Judge NG when out of the standard value.

### 2. COMPONENT DESCRIPTION

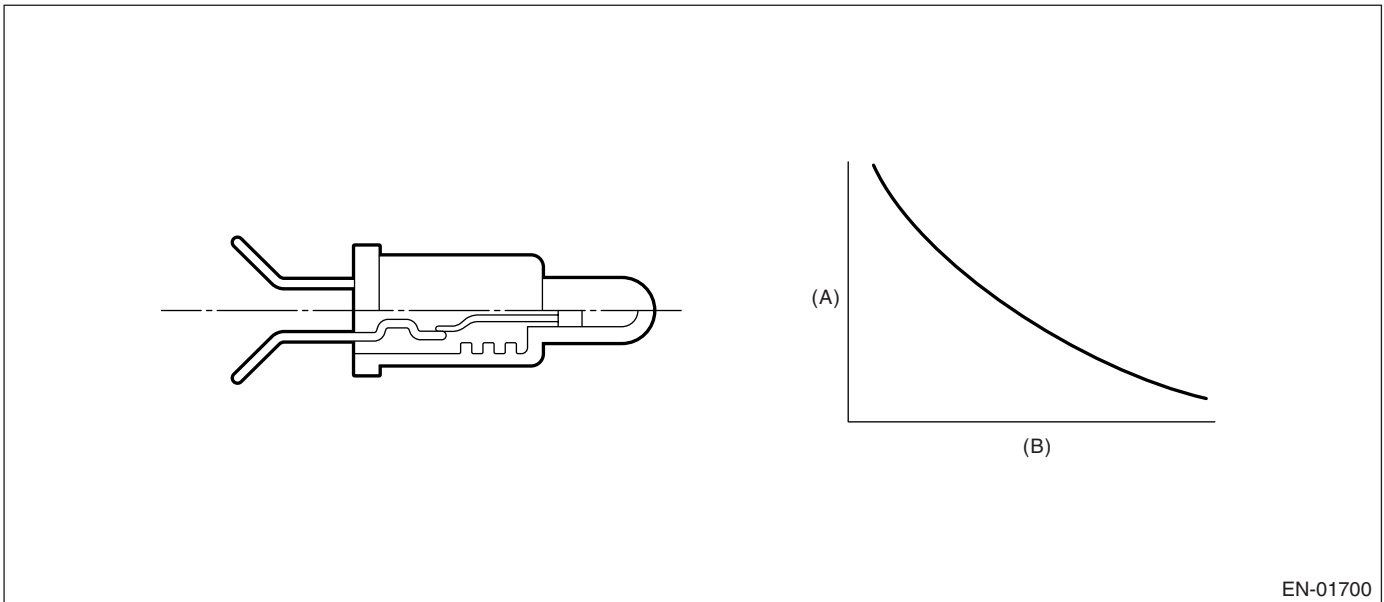

EN-01700

(A) Resistance value ( $\Omega$ )

(B) Fuel temperature  $^{\circ}\text{C}$  ( $^{\circ}\text{F}$ )

### 3. ENABLE CONDITION

Secondary Parameters	Enable Conditions
None	

### 4. GENERAL DRIVING CYCLE

Always perform the diagnosis continuously.

# Diagnostic Trouble Code (DTC) Detecting Criteria

## GENERAL DESCRIPTION

---

### 5. DIAGNOSTIC METHOD

#### • Abnormality Judgment

Judge NG when the continuous time of completing the malfunction criteria below becomes more than 2.5 seconds.

#### Judgment Value

Malfunction Criteria	Threshold Value
Output voltage	$\geq 4.716 \text{ V}$
Battery voltage	$\geq 10.9 \text{ V}$

**Time Needed for Diagnosis:** 2.5 seconds

**Malfunction Indicator Light Illumination:** Illuminates as soon as the malfunction occurs.

#### • Normality Judgment

Judge OK when the cumulative time until completing the malfunction criteria below becomes more than 2.5 seconds.

#### Judgment Value

Malfunction Criteria	Threshold Value
Output voltage	$< 4.716 \text{ V}$
Battery voltage	$\geq 10.9 \text{ V}$

### 6. DTC CLEAR CONDITION

- When the OK idling cycle was completed 40 times in a row
- When "Clear Memory" was performed

### 7. MALFUNCTION INDICATOR LIGHT CLEAR CONDITION

- When the OK driving cycle was completed 3 times in a row
- When "Clear Memory" was performed

### 8. FAIL SAFE

None

### 9. ECM OPERATION AT DTC SETTING

Memorize the freeze frame data. (For test mode \$02)



# Diagnostic Trouble Code (DTC) Detecting Criteria

GENERAL DESCRIPTION

## AO:DTC P0196 ENGINE OIL TEMPERATURE SENSOR CIRCUIT RANGE/PERFORMANCE

### 1. OUTLINE OF DIAGNOSIS

Detect the malfunction of engine oil temperature sensor output property.

Judge NG when the engine oil temperature does not increase regardless of the driving condition that engine oil temperature may be thought to increase.

### 2. ENABLE CONDITION

Secondary Parameters	Enable Conditions
Battery voltage	≥ 10.9 V
Engine speed	500 rpm

### 3. GENERAL DRIVING CYCLE

Always perform the diagnosis continuously.

### 4. DIAGNOSTIC METHOD

#### • Abnormality Judgment

Judge NG when the malfunction criteria below is completed.

#### Judgment Value

Malfunction Criteria	Threshold Value
Engine oil temperature	< 15°C (59°F)
Timer for diagnosis of oil temperature sensor after engine starting	≥ Judgment value of timer for diagnosis of oil temperature sensor after engine starting

Timer for diagnosis of oil temperature sensor after engine starting (Timer for diagnosis)

a) Timer stop at fuel cut mode.

b) During the driving condition (except a) above), timer count up by 64ms + TOILCNT ms at every 64ms.

Where, TOILCNT is determined as follows,

TOILCNT = 0 at idle switch on,

Refer to the following table for TWCNT with idle switch OFF.

		Vehicle speed km/h (MPH)							
		0 (0)	8 (5)	16 (10)	24 (15)	32 (20)	40 (25)	48 (30)	56 (35)
Temp. °C (°F)	-30 (-22)	64 ms	73.2 ms	83.9 ms	96.3 ms	113.2 ms	133.9 ms	160.2 ms	194.6 ms
	-20 (-4)	64 ms	73.3 ms	84 ms	96.6 ms	113.7 ms	135 ms	162 ms	197.4 ms
	-10 (14)	64 ms	73.4 ms	84.2 ms	96.9 ms	114.5 ms	136.4 ms	164.4 ms	201.5 ms
	0 (32)	64 ms	73.5 ms	84.5 ms	97.4 ms	115.6 ms	138.5 ms	168 ms	207.6 ms
	10 (50)	102.2 ms	114.8 ms	129.4 ms	146.7 ms	171.7 ms	203.4 ms	245.1 ms	302.1 ms

Judgment value of Timer for diagnosis of oil temperature sensor after engine starting (t)

$$t = 1,882,940 - 43,302 \times T_i \quad (t \geq 1,882,940)$$

T<sub>i</sub> is a lowest engine coolant temperature after starting the engine.

**Time needed for diagnosis:** To be determined.

**Malfunction Indicator Light Illumination:** Illuminates when malfunction occurs in 2 continuous driving cycles.

#### • Normality Judgment

Judge OK when the malfunction criteria below is completed.

#### Judgment Value

Malfunction Criteria	Threshold Value
Engine oil temperature	≥ 15°C (59°F)

# Diagnostic Trouble Code (DTC) Detecting Criteria

## GENERAL DESCRIPTION

---

### 5. DTC CLEAR CONDITION

- When the OK idling cycle was completed 40 times in a row
- When “Memory Clear” was performed

### 6. MALFUNCTION INDICATOR LIGHT CLEAR CONDITION

- When the OK idling cycle was completed 3 times in a row
- When “Memory Clear” was performed

### 7. FAIL SAFE

Oil temperature sensor process: Fix the engine oil temperature 70°C (158°F)

### 8. ECM OPERATION AT DTC SETTING

Memorize the freeze frame data. (For test mode \$02)

## AP:DTC P0197 ENGINE OIL TEMPERATURE SENSOR CIRCUIT LOW

### 1. OUTLINE OF DIAGNOSIS

Detect open or short circuit of engine oil temperature sensor.  
Judge NG when out of the standard value.

### 2. ENABLE CONDITION

Secondary Parameters	Enable Conditions
None	

### 3. GENERAL DRIVING CYCLE

Always perform the diagnosis continuously.

### 4. DIAGNOSTIC METHOD

Judge NG when the continuous time of completing malfunction criteria below becomes more than 0.5 seconds.

Judge OK and clear NG when the malfunction criteria below is not completed.

#### Judgment Value

Malfunction Criteria	Threshold Value
Output voltage	≤ 0.166 V

**Time needed for diagnosis:** 0.5 seconds

**Malfunction Indicator Light Illumination:** Illuminates as soon as malfunction occurs.

### 5. DTC CLEAR CONDITION

- When the OK idling cycle was completed 40 times in a row
- When “Memory Clear” was performed

### 6. MALFUNCTION INDICATOR LIGHT CLEAR CONDITION

- When the OK idling cycle was completed 3 times in a row
- When “Memory Clear” was performed

### 7. FAIL SAFE

Oil temperature sensor process: Fix the engine oil temperature 70°C (158°F)

### 8. ECM OPERATION AT DTC SETTING

Memorize the freeze frame data. (For test mode \$02)

# Diagnostic Trouble Code (DTC) Detecting Criteria

GENERAL DESCRIPTION

## AQ:DTC P0198 ENGINE OIL TEMPERATURE SENSOR CIRCUIT HIGH

### 1. OUTLINE OF DIAGNOSIS

Detect the open or the short circuit of engine oil temperature sensor.  
Judge NG when out of the judgment value.

### 2. ENABLE CONDITION

Secondary Parameters	Enable Conditions
None	

### 3. GENERAL DRIVING CYCLE

Always perform the diagnosis continuously.

### 4. DIAGNOSTIC METHOD

Judge NG when the continuous time of completing malfunction criteria below becomes more than 0.5 seconds.

Judge OK and clear NG when the malfunction criteria below is not completed.

#### Judgment Value

Malfunction Criteria	Threshold Value
Output voltage	$\geq 4.716$ V

**Time needed for diagnosis:** 0.5 seconds

**Malfunction Indicator Light Illumination:** Illuminates as soon as malfunction occurs.

### 5. DTC CLEAR CONDITION

- When the OK idling cycle was completed 40 times in a row
- When "Memory Clear" was performed

### 6. MALFUNCTION INDICATOR LIGHT CLEAR CONDITION

- When the OK idling cycle was completed 3 times in a row
- When "Memory Clear" was performed

### 7. FAIL SAFE

Oil temperature sensor process: Fix the engine oil temperature 70°C (158°F)

### 8. ECM OPERATION AT DTC SETTING

Memorize the freeze frame data. (For test mode \$02)

# Diagnostic Trouble Code (DTC) Detecting Criteria

## GENERAL DESCRIPTION

### AR:DTC P0222 THROTTLE/PEDAL POSITION SENSOR/SWITCH “B” CIRCUIT LOW INPUT

#### 1. OUTLINE OF DIAGNOSIS

Detect the open or short circuit of throttle position sensor 2.  
Judge NG when out of the standard value.

#### 2. COMPONENT DESCRIPTION

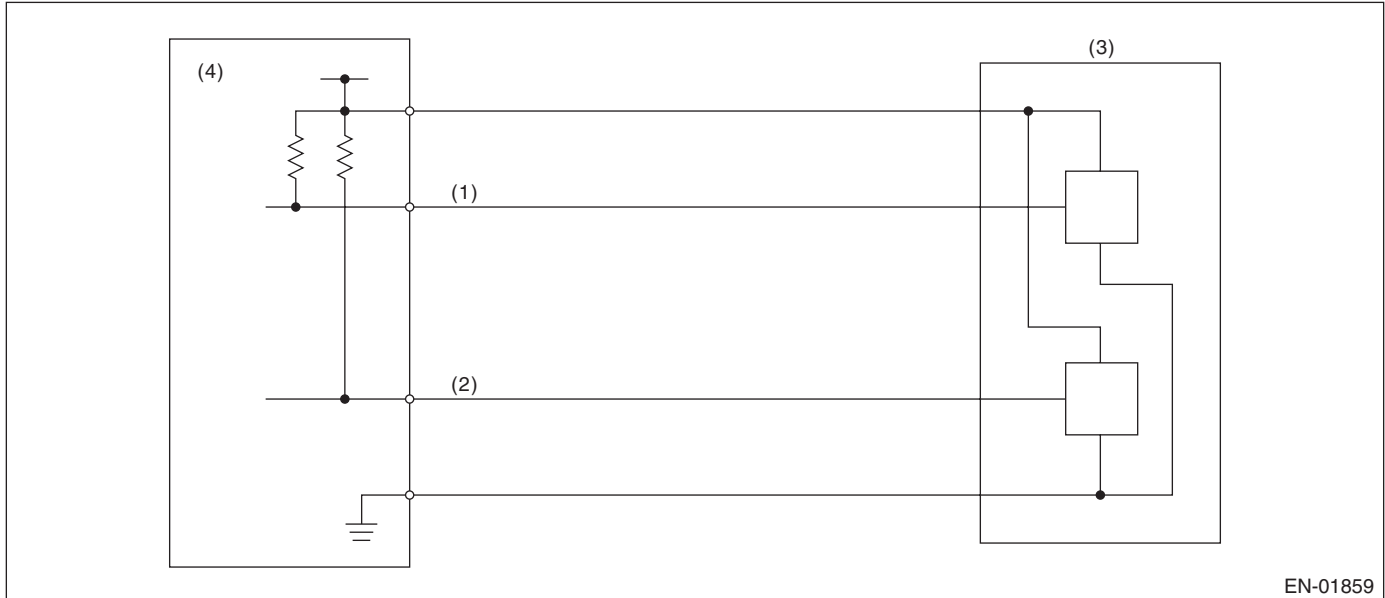

- (1) Throttle position sensor 1 signal      (3) Throttle position sensor  
(2) Throttle position sensor 2 signal      (4) Engine control module (ECM)

#### 3. ENABLE CONDITION

Secondary Parameters	Enable Conditions
Ignition switch	ON

#### 4. GENERAL DRIVING CYCLE

Always perform the diagnosis continuously.

#### 5. DIAGNOSTIC METHOD

Judge OK and clear the NG when the malfunction criteria below are completed.

##### Judgment Value

Malfunction Criteria	Threshold Value
Sensor 2 input voltage	$\geq 0.749$ V

**Time Needed for Diagnosis:** 24 milliseconds

**Malfunction Indicator Light Illumination:** Illuminates as soon as malfunction occurs.

#### 6. DTC CLEAR CONDITION

- When the OK idling cycle was completed 40 times in a row
- When “Clear Memory” was performed (Only with engine stopped)

#### 7. MALFUNCTION INDICATOR LIGHT CLEAR CONDITION

- When the OK driving cycle was completed 3 times in a row
- When “Clear Memory” was performed (Only with engine stopped)

## 8. FAIL SAFE

Stop power distribution to electronic throttle control motor. (Throttle opening is fixed to 6°.)

## 9. ECM OPERATION AT DTC SETTING

Memorize the freeze frame data. (For test mode \$02)

# AS:DTC P0223 THROTTLE/PEDAL POSITION SENSOR/SWITCH "B" CIRCUIT HIGH INPUT

### 1. OUTLINE OF DIAGNOSIS

Detect the open or short circuit of throttle position sensor 2.  
Judge NG when out of the standard value.

### 2. COMPONENT DESCRIPTION

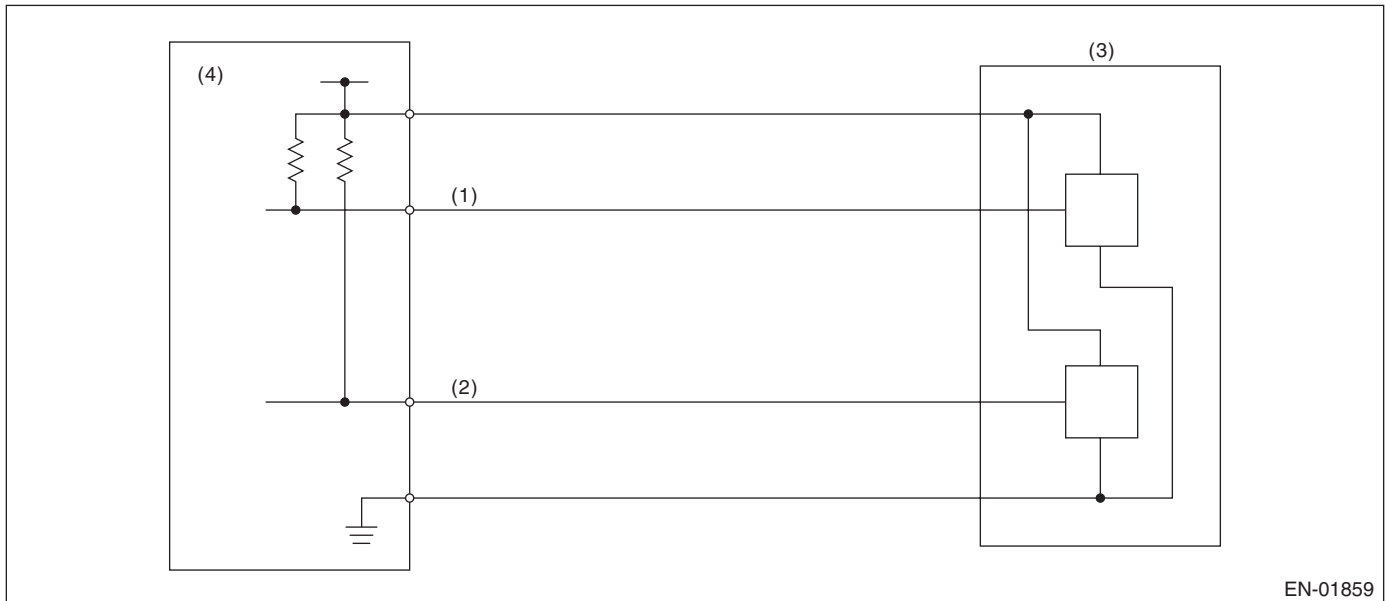

EN-01859

- |                                       |                                 |
|---------------------------------------|---------------------------------|
| (1) Throttle position sensor 1 signal | (3) Throttle position sensor    |
| (2) Throttle position sensor 2 signal | (4) Engine control module (ECM) |

### 3. ENABLE CONDITION

Secondary Parameters	Enable Conditions
Ignition switch	ON

### 4. GENERAL DRIVING CYCLE

Always perform the diagnosis continuously.

### 5. DIAGNOSTIC METHOD

Judge OK and clear the NG when the malfunction criteria below are completed.

#### Judgment Value

Malfunction Criteria	Threshold Value
Sensor 2 input voltage	$\leq 4.747$ V

**Time Needed for Diagnosis:** 24 milliseconds

**Malfunction Indicator Light Illumination:** Illuminates as soon as malfunction occurs.

# Diagnostic Trouble Code (DTC) Detecting Criteria

## GENERAL DESCRIPTION

---

### 6. DTC CLEAR CONDITION

- When the OK idling cycle was completed 40 times in a row
- When “Clear Memory” was performed (Only with engine stopped)

### 7. MALFUNCTION INDICATOR LIGHT CLEAR CONDITION

- When the OK driving cycle was completed 3 times in a row
- When “Clear Memory” was performed (Only with engine stopped)

### 8. FAIL SAFE

Stop power distribution to electronic throttle control motor. (Throttle opening is fixed to 6°.)

### 9. ECM OPERATION AT DTC SETTING

Memorize the freeze frame data. (For test mode \$02)

## AT:DTC P0301 CYLINDER 1 MISFIRE DETECTED

### 1. OUTLINE OF DIAGNOSIS

Detect whether the misfire occurred or not. (Revolution fluctuation method) Monitoring the misfire which influences exhaust deterioration (1.5 times of FTP) and catalyst damage is made obligatory by the law. Misfire affecting these two has three patterns below.

- Intermittent misfire (The same cylinder misfires in random, or different cylinders misfire in random.): FTP 1.5 times misfire
- Every time misfire (The same cylinder misfires every time.): FTP 1.5 times misfire, Catalyst damage misfire

The following detecting methods are adopted for these detection.

1) Intermittent misfire: FTP 1.5 times misfire

- 180° Interval Difference Method (MT: 1,800 rpm or less; AT: None)
- 360° Interval Difference Method (whole range)
- 720° Interval Difference Method (3,000 rpm or less)

2) Every time misfire: FTP 1.5 times misfire, Catalyst damage misfire

- 360° Interval Difference Method

### 2. ENABLE CONDITION

Secondary Parameters	Enable Conditions
All secondary parameter enable conditions	More than 1 second
Intake manifold pressure change during 0.5 engine rev.	< 13.3 kPa (100 mmHg, 3.94 inHg)
Throttle position change during 16 milliseconds	< 21°
Fuel shut-off function	Not operating
Atmospheric pressure	≥ 75.0 kPa (563 mmHg, 22.2 inHg)
Fuel level	≥ 9.0 ℓ (2.38 US gal, 1.98 Imp gal)
AT torque control	Not in operation
Evaporative system leak check	Not in operation
Engine speed	460 — 6,200 rpm
Intake manifold pressure	> Map 3
Battery voltage	≥ 8 V
Conclusion of fuel parameter	Not supervolatile

# Diagnostic Trouble Code (DTC) Detecting Criteria

GENERAL DESCRIPTION

## Map3

### MT (Vehicle Speed < 64.4 km/h (40 MPH))

rpm	650	1000	1500	2000	2500	3000	3500	4000	4500	5000	5500	6000	6400
kPa	25.6	23.1	20.0	20.0	20.0	21.6	26.4	28.0	29.5	32.4	36.4	39.9	44.5
(mmHg, inHg)	(192, 7.56)	(173, 6.82)	(150, 5.91)	(150, 5.91)	(150, 5.91)	(162, 6.38)	(198, 7.80)	(210, 8.27)	(221, 8.71)	(243, 9.57)	(273, 10.75)	(299, 11.78)	(324, 13.14)

### MT (Vehicle Speed ≥ 64.4 km/h (40 MPH))

rpm	650	1000	1500	2000	2500	3000	3500	4000	4500	5000	5500	6000	6400
kPa	31.6	31.6	31.6	31.1	31.3	33.1	33.9	28.8	30.1	33.3	36.9	40.1	44.5
(mmHg, inHg)	(237, 9.33)	(237, 9.33)	(237, 9.33)	(233, 9.19)	(235, 9.24)	(248, 9.78)	(254, 10.01)	(216, 8.51)	(226, 8.89)	(250, 9.84)	(277, 10.90)	(301, 11.84)	(324, 13.14)

## AT

rpm	700	1000	1500	2000	2500	3000	3500	4000	4500	5000	5500	6000	6400
kPa	25.6	24.4	22.0	22.4	22.8	23.9	29.9	31.3	29.9	35.6	39.3	43.3	44.5
(mmHg, inHg)	(192, 7.56)	(183, 7.21)	(165, 6.50)	(168, 6.62)	(171, 6.73)	(179, 7.06)	(224, 8.83)	(235, 9.24)	(244, 8.83)	(267, 10.51)	(295, 11.61)	(325, 12.79)	(334, 13.14)

## 3. GENERAL DRIVING CYCLE

- Detecting misfire between idling and high revolution.
- Perform the diagnosis continuously.

# Diagnostic Trouble Code (DTC) Detecting Criteria

## GENERAL DESCRIPTION

### 4. DIAGNOSTIC METHOD

When the misfire occurred, the engine speed is decreased and the crankshaft position speed will change. Calculate the interval difference value (diagnostic value) from crankshaft position speed by the following formula, and judge whether the misfire occurs or not comparing the calculated result with judgment value. Counting the number of misfire up, and if the misfire ratio is higher during 1,000 rev. or 200 rev., judge NG for the corresponding cylinder.

Calculate the diagnostic value (from crankshaft position speed)

- Misfire detection every single ignition (Compare diagnostic value with judgment value)
- 180° Interval Difference Method
  - 360° Interval Difference Method
  - 720° Interval Difference Method

- NG judgment (Judge misfire occurrence required by the law) (Compare number of misfire with judgment)
- FTP1.5 times misfire NG judgment
  - Catalyst damage misfire NG judgment

As the following figure, pick out a random cylinder as the standard and name it omg 0. And the former crankshaft position speed is named omg 1, the second former crankshaft position speed is named omg 2, the third is named omg 3, and the following is the same.

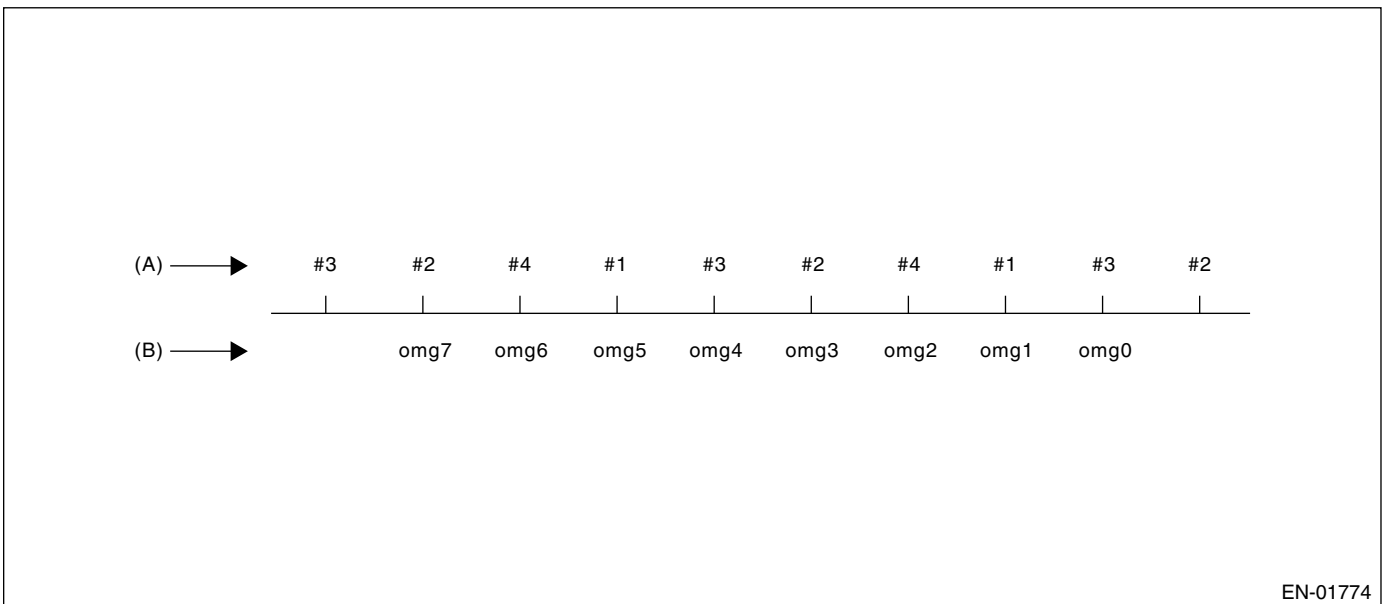

EN-01774

(A) Ignition order

(B) Crankshaft position speed



# Diagnostic Trouble Code (DTC) Detecting Criteria

GENERAL DESCRIPTION

## • 180° Interval Difference Method

Diagnosis value  $domg\ 180 = (omg\ -1\ omg\ 0) - (omg\ 5 - omg\ 1)/4$

Judge misfire occurs in the following cases.

- $domg\ 180 >$  judgment value of positive side
- $domg\ 180 \leq$  judgment value of negative side  
(judgment value before 180°CA)

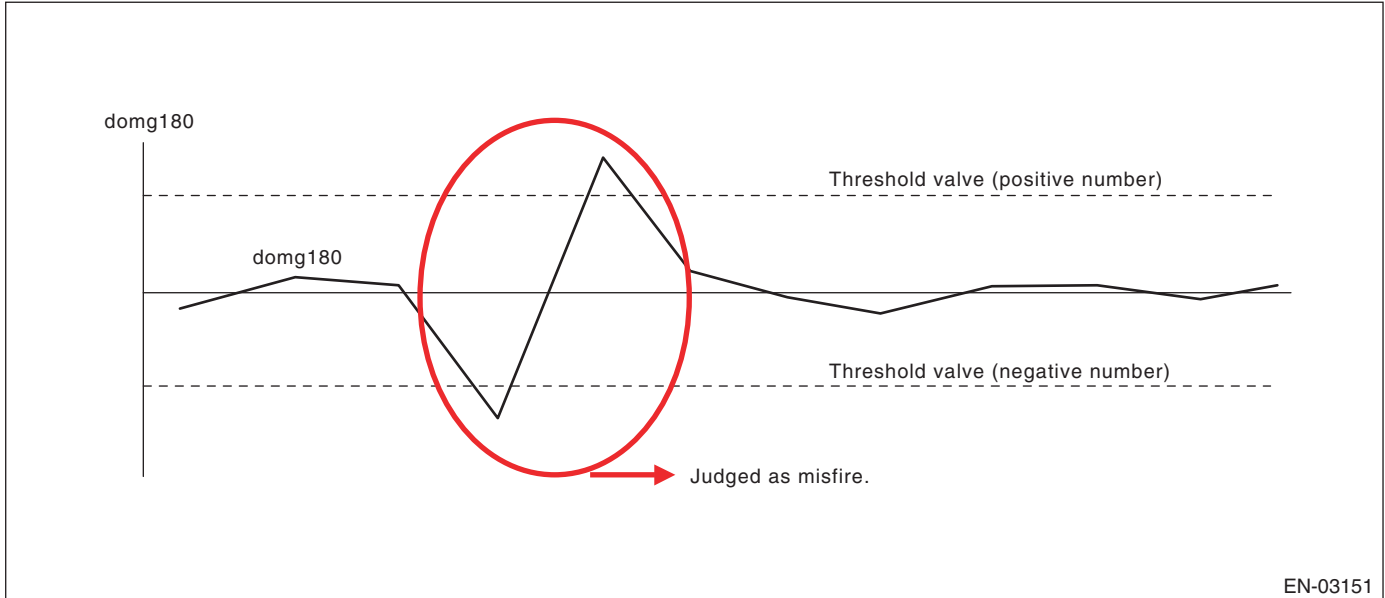

## • 360° Interval Difference Method

Diagnosis value  $domg\ 360 = (omg\ 1 - omg\ 0) - (omg\ 3 - omg\ 2)$

Misfire judgment  $domg\ 360 >$  judgment value  $\rightarrow$  Misfire occurs

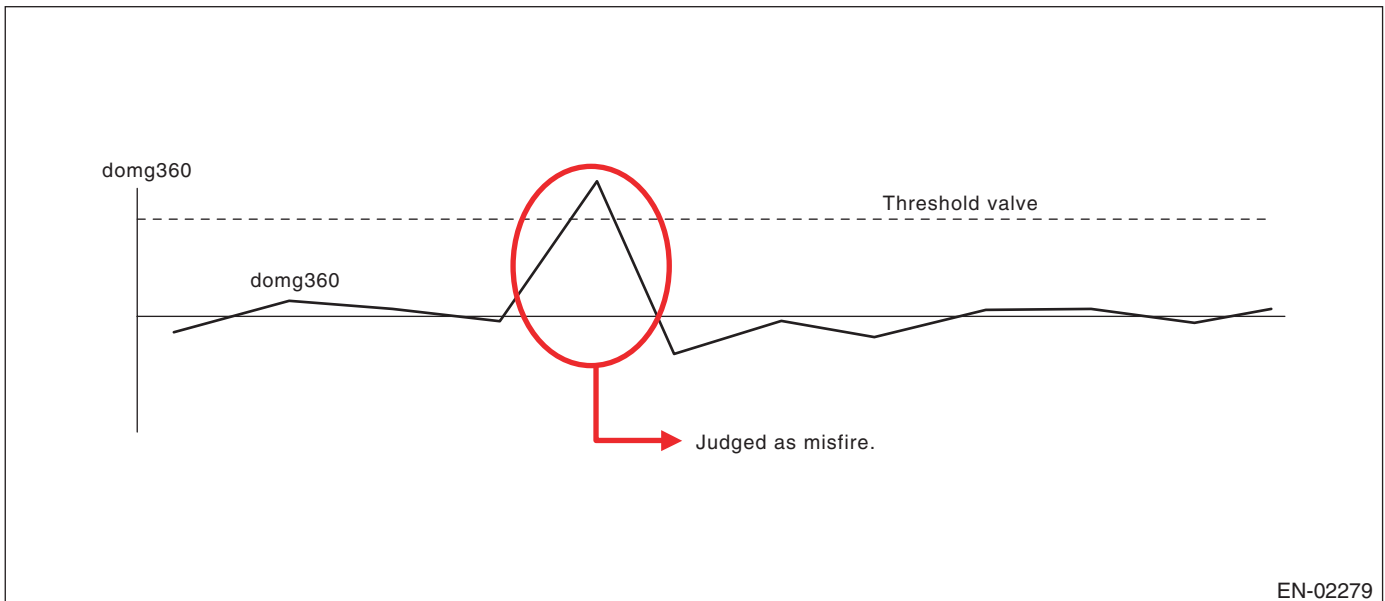

# Diagnostic Trouble Code (DTC) Detecting Criteria

## GENERAL DESCRIPTION

### • 720° Interval Difference Method

Diagnosis value  $domg\ 720 = (omg\ 1 - omg\ 0) - (omg\ 5 - omg\ 4)$

Misfire judgment  $domg\ 720 > \text{judgment value} \rightarrow \text{Misfire occurs}$

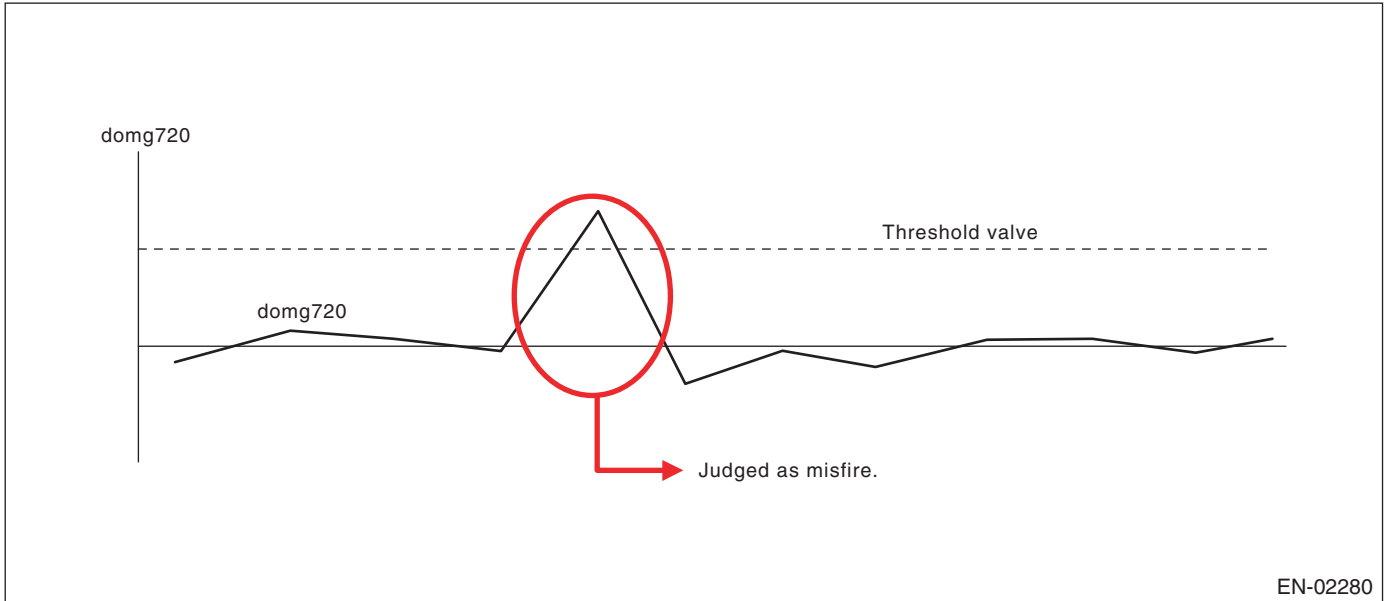

### • FTP 1.5 times misfire (Misfire occurrence level affecting exhaust gas)

**Judgment Value (Judge that malfunction occurs when the misfire ratio is high in 1,000 engine revs.)**

Malfunction Criteria	Threshold Value
FTP emission judgment value	> 1.0% in 1,000 revs.

**Time Needed for Diagnosis:** 1,000 engine revs.

**Malfunction Indicator Light Illumination:** Illuminates when malfunction occurs in 2 continuous driving cycles.

### • Catalyst damage misfire (Misfire occurrence level damaging catalyst)

**Judgment Value (Judge that malfunction occurs when the misfire ratio is high in 200 engine revs. (400 ignitions))**

Malfunction Criteria	Threshold Value
Catalyst damage misfire judgment value	See Map 1

# Diagnostic Trouble Code (DTC) Detecting Criteria

GENERAL DESCRIPTION

## Map 1 Fault criteria threshold for misfire which would result in catalyst damage

percentage		Intake air (g (oz)/rev.)									
		0.16 (0.0006)	0.28 (0.010)	0.4 (0.014)	0.52 (0.018)	0.64 (0.023)	0.76 (0.027)	0.92 (0.032)	1.1 (0.039)	1.2 (0.042)	1.3 (0.046)
Engine speed (rpm)	700	25	25	25	25	22.5	20	16	12	12	12
	1000	25	25	25	25	22.5	20	15.75	11	11	11
	1500	25	25	22.5	20	18.25	16.75	13.5	10	10	10
	2000	20	20	20	20	17	14.25	12.75	11	11	11
	2500	20	20	18.25	16.75	15.5	14.25	12.75	11	11	11
	3000	16.75	16.75	15.5	14.25	12.75	11	11	11	11	11
	3500	16.75	16.75	14	11	10	9	8.5	7.75	7.75	7.75
	4000	14.25	14.25	11	7.75	6	5	5	5	5	5
	4500	11	11	8.25	7.75	5	5	5	5	5	5
	5000	11	11	9.5	7.75	5	5	5	5	5	5
	5500	9	9	7.75	6.75	5	5	5	5	5	5
	6000	9	5	5	5	5	5	5	5	5	5
6400	9	5	5	5	5	5	5	5	5	5	

These figures mean the misfire ratio (%) in 400 ignitions; for example, 22.5 (%) means 400 (ignition) × 22.5 (%) = 90 (ignition) or more, so this case is judged misfire.

**Time Needed for Diagnosis:** 200 engine revs.

**Malfunction Indicator Light Illumination:** Illuminates as soon as the malfunction occurs.

### 5. DTC CLEAR CONDITION

- When the OK idling cycle was completed 40 times in a row
- When "Clear Memory" was performed

### 6. MALFUNCTION INDICATOR LIGHT CLEAR CONDITION

- When the OK driving cycle was completed 3 times in a row
- When "Clear Memory" was performed

### 7. FAIL SAFE

None

### 8. ECM OPERATION AT DTC SETTING

Memorize the freeze frame data. (For test mode \$02)

## AU: DTC P0302 CYLINDER 2 MISFIRE DETECTED

### 1. OUTLINE OF DIAGNOSIS

For the diagnostic procedure, refer to DTC P0301. <Ref. to GD(H4SO)-78, DTC P0301 CYLINDER 1 MISFIRE DETECTED, Diagnostic Trouble Code (DTC) Detecting Criteria.>

## AV: DTC P0303 CYLINDER 3 MISFIRE DETECTED

### 1. OUTLINE OF DIAGNOSIS

For the diagnostic procedure, refer to DTC P0301. <Ref. to GD(H4SO)-78, DTC P0301 CYLINDER 1 MISFIRE DETECTED, Diagnostic Trouble Code (DTC) Detecting Criteria.>

## AW: DTC P0304 CYLINDER 4 MISFIRE DETECTED

### 1. OUTLINE OF DIAGNOSIS

For the diagnostic procedure, refer to DTC P0301. <Ref. to GD(H4SO)-78, DTC P0301 CYLINDER 1 MISFIRE DETECTED, Diagnostic Trouble Code (DTC) Detecting Criteria.>

# Diagnostic Trouble Code (DTC) Detecting Criteria

## GENERAL DESCRIPTION

### AX:DTC P0327 KNOCK SENSOR 1 CIRCUIT LOW INPUT (BANK 1 OR SINGLE SENSOR)

#### 1. OUTLINE OF DIAGNOSIS

Detect the open or short circuit of the knock sensor. Judge NG when out of the standard value.

#### 2. COMPONENT DESCRIPTION

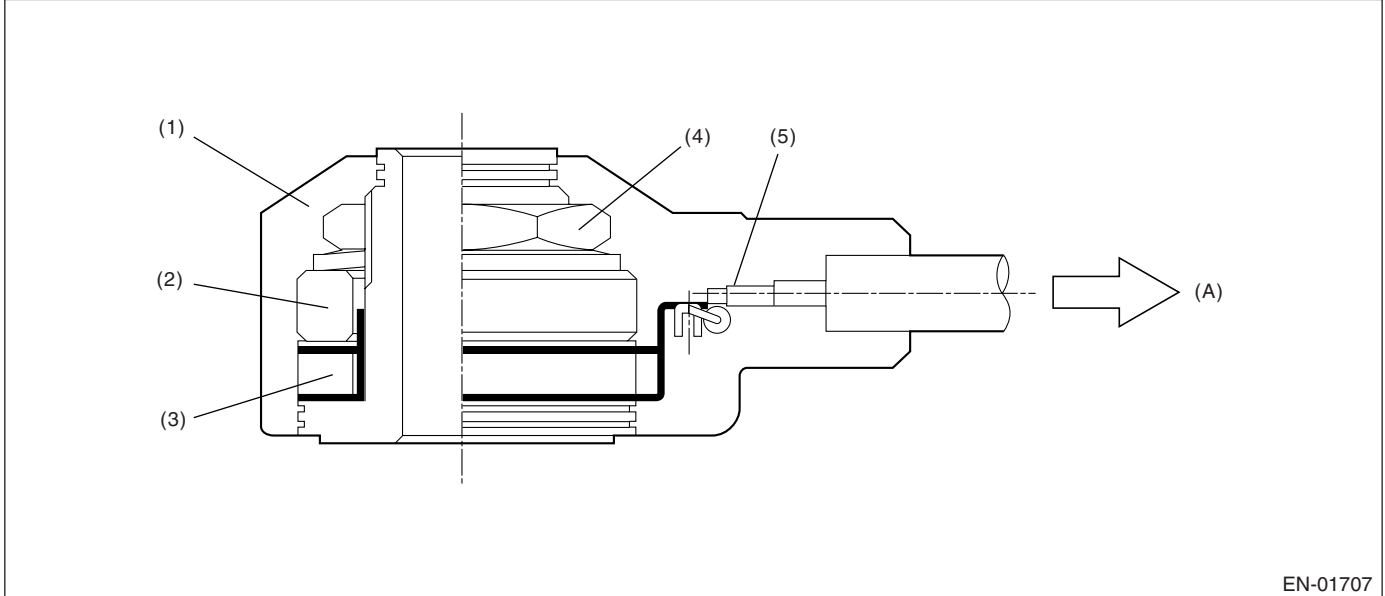

- (1) Case
- (2) Weight
- (3) Piezoelectric element

- (4) Nut
- (5) Resistance

- (A) To knock sensor harness

#### 3. ENABLE CONDITION

Secondary Parameters	Enable Conditions
None	

#### 4. GENERAL DRIVING CYCLE

Always perform the diagnosis continuously.

#### 5. DIAGNOSTIC METHOD

##### • Abnormality Judgment

Judge NG when the continuous time of completing the malfunction criteria below becomes more than 1 second.

##### Judgment Value

Malfunction Criteria	Threshold Value
Output voltage	< 0.238 V
Ignition switch	ON

**Time Needed for Diagnosis:**1 second

**Malfunction Indicator Light Illumination:**Illuminates as soon as the malfunction occurs.

# Diagnostic Trouble Code (DTC) Detecting Criteria

GENERAL DESCRIPTION

## • Normality Judgment

Judge OK and clear NG when the malfunction criteria below are completed.

### Judgment Value

Malfunction Criteria	Threshold Value
Output voltage	$\geq 0.25$ V
Ignition switch	ON

## 6. DTC CLEAR CONDITION

- When the OK idling cycle was completed 40 times in a row
- When "Clear Memory" was performed

## 7. MALFUNCTION INDICATOR LIGHT CLEAR CONDITION

- When the OK driving cycle was completed 3 times in a row
- When "Clear Memory" was performed

## 8. FAIL SAFE

None

## 9. ECM OPERATION AT DTC SETTING

Memorize the freeze frame data. (For test mode \$02)

# Diagnostic Trouble Code (DTC) Detecting Criteria

## GENERAL DESCRIPTION

### AY:DTC P0328 KNOCK SENSOR 1 CIRCUIT HIGH INPUT (BANK 1 OR SINGLE SENSOR)

#### 1. OUTLINE OF DIAGNOSIS

Detect the open or short circuit of the knock sensor. Judge NG when out of the standard value.

#### 2. COMPONENT DESCRIPTION

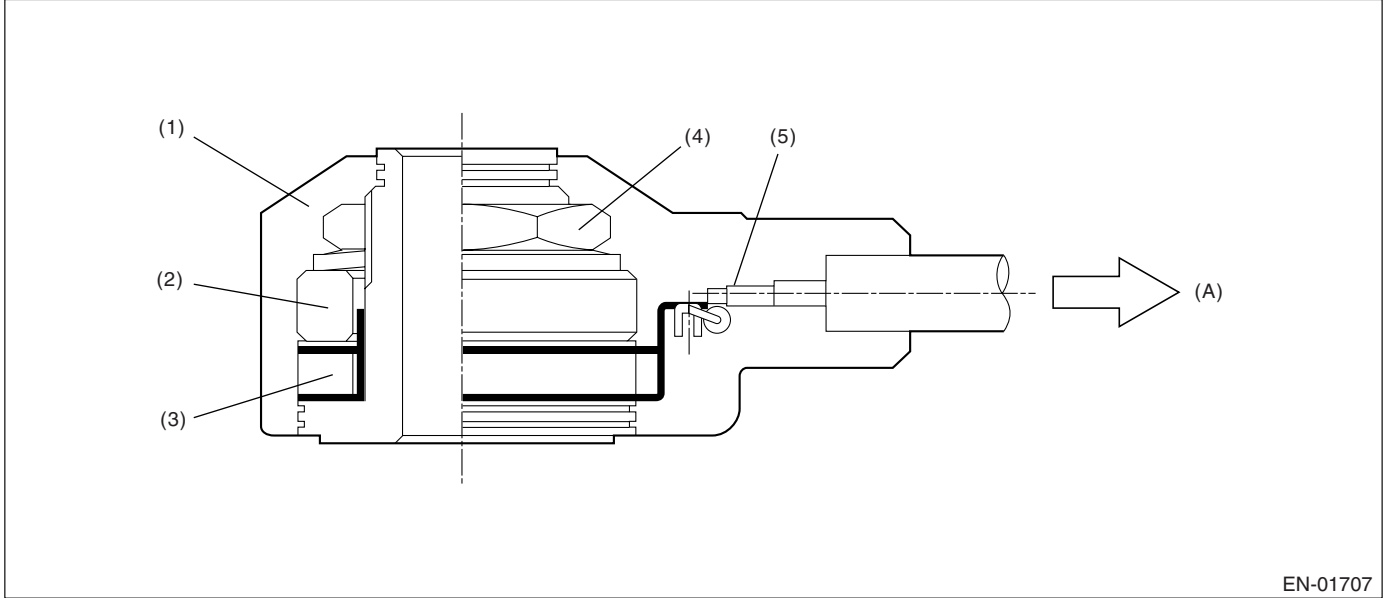

- (1) Case
- (2) Weight
- (3) Piezoelectric element

- (4) Nut
- (5) Resistance

- (A) To knock sensor harness

#### 3. ENABLE CONDITION

Secondary Parameters	Enable Conditions
None	

#### 4. GENERAL DRIVING CYCLE

Always perform diagnosis continuously.

#### 5. DIAGNOSTIC METHOD

##### • Abnormality Judgment

Judge NG when the continuous time of completing the malfunction criteria below becomes more than 1 second.

##### Judgment Value

Malfunction Criteria	Threshold Value
Output voltage	$\geq 4.714$ V
Ignition switch	ON

**Time Needed for Diagnosis:**1 second

**Malfunction Indicator Light Illumination:**Illuminates as soon as the malfunction occurs.

# Diagnostic Trouble Code (DTC) Detecting Criteria

GENERAL DESCRIPTION

## • Normality Judgment

Judge OK and clear NG when the malfunction criteria below are completed.

### Judgment Value

Malfunction Criteria	Threshold Value
Output voltage	< 4.7 V
Ignition switch	ON

## 6. DTC CLEAR CONDITION

- When the OK idling cycle was completed 40 times in a row
- When "Clear Memory" was performed

## 7. MALFUNCTION INDICATOR LIGHT CLEAR CONDITION

- When the OK driving cycle was completed 3 times in a row
- When "Clear Memory" was performed

## 8. FAIL SAFE

None

## 9. ECM OPERATION AT DTC SETTING

Memorize the freeze frame data. (For test mode \$02)

# Diagnostic Trouble Code (DTC) Detecting Criteria

## GENERAL DESCRIPTION

### AZ:DTC P0335 CRANKSHAFT POSITION SENSOR "A" CIRCUIT

#### 1. OUTLINE OF DIAGNOSIS

Detect the open or short circuit of crankshaft position sensor. Judge NG when the crankshaft signal does not input regardless of turning the starter.

#### 2. COMPONENT DESCRIPTION

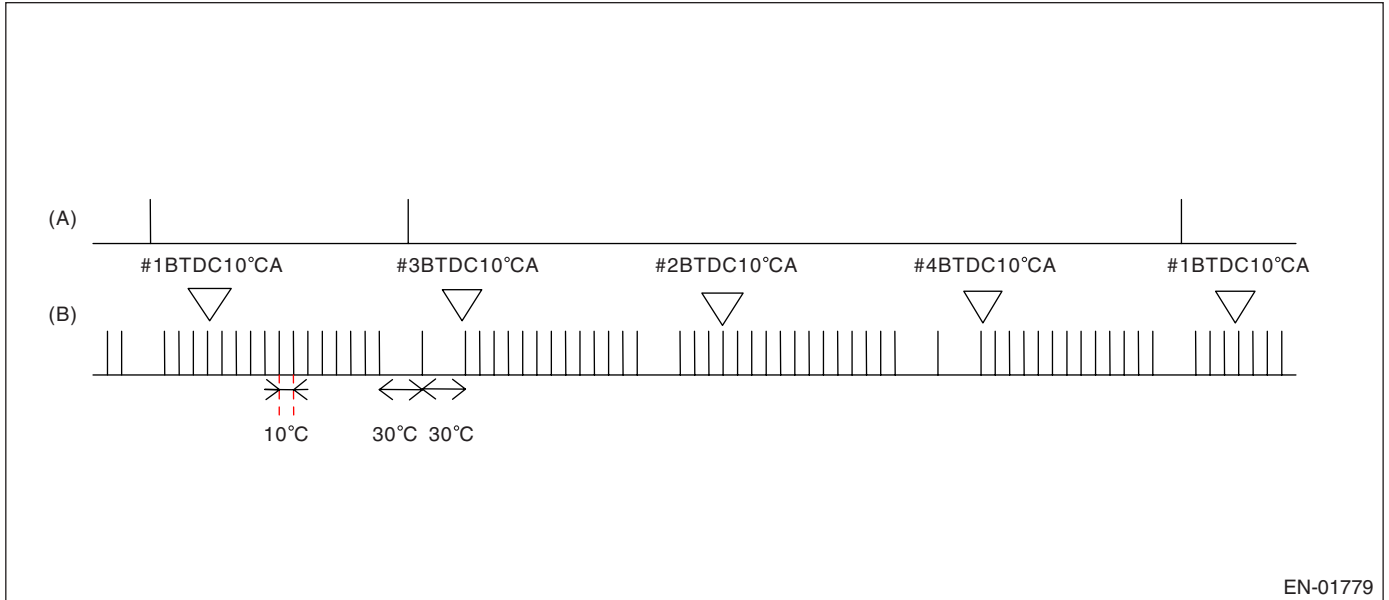

(A) Camshaft signal

(B) Crankshaft signal

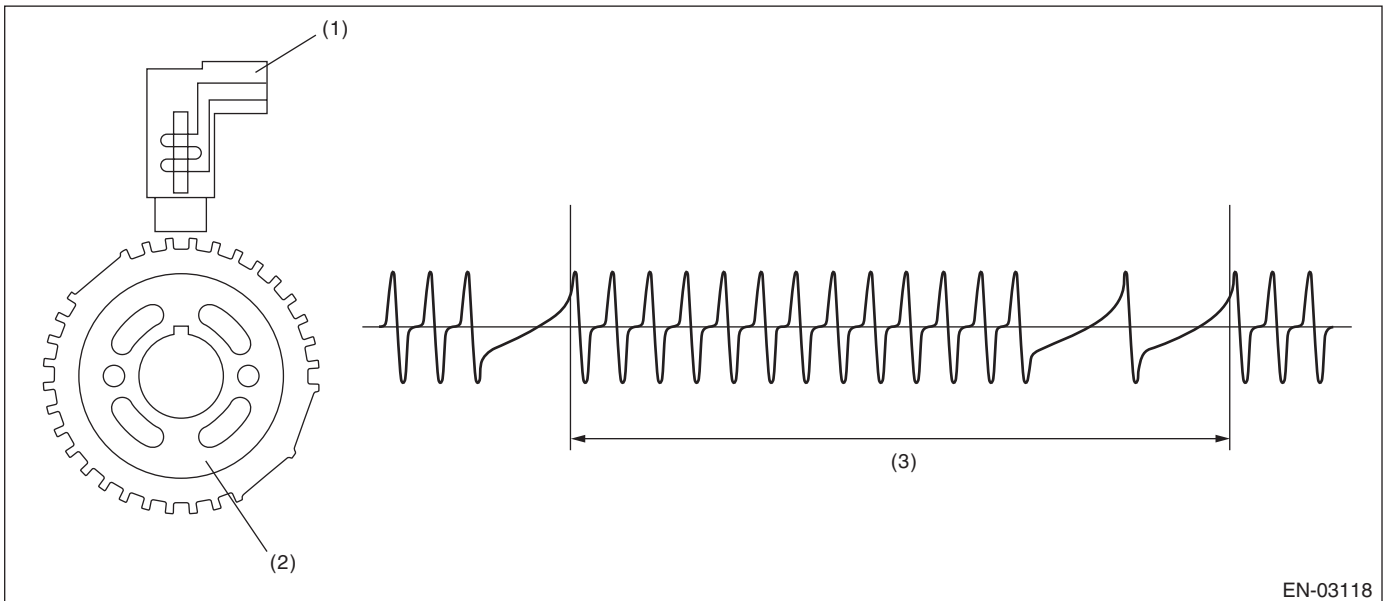

(1) Crankshaft position sensor

(2) Crank sprocket

(3) Crankshaft half-turn

#### 3. ENABLE CONDITION

Secondary Parameters	Enable Conditions
None	



# Diagnostic Trouble Code (DTC) Detecting Criteria

GENERAL DESCRIPTION

## 4. GENERAL DRIVING CYCLE

Always perform the diagnosis continuously.

## 5. DIAGNOSTIC METHOD

### • Abnormality Judgment

Judge NG when the continuous time of completing the malfunction criteria below becomes more than 3 seconds.

### Judgment Value

Malfunction Criteria	Threshold Value
Starter switch	ON
Crankshaft position sensor signal	Not detected
Battery voltage	$\geq 8$ V

**Time Needed for Diagnosis:**3 seconds

**Malfunction Indicator Light Illumination:**Illuminates as soon as the malfunction occurs.

### • Normality Judgment

Judge OK when the malfunction criteria below are completed.

### Judgment Value

Malfunction Criteria	Threshold Value
Crankshaft position sensor signal	Input exists
Battery voltage	$\geq 8$ V

## 6. DTC CLEAR CONDITION

- When the OK idling cycle was completed 40 times in a row
- When "Clear Memory" was performed

## 7. MALFUNCTION INDICATOR LIGHT CLEAR CONDITION

- When the OK driving cycle was completed 3 times in a row
- When "Clear Memory" was performed

## 8. FAIL SAFE

None

## 9. ECM OPERATION AT DTC SETTING

Memorize the freeze frame data. (For test mode \$02)

# Diagnostic Trouble Code (DTC) Detecting Criteria

## GENERAL DESCRIPTION

### BA:DTC P0336 CRANKSHAFT POSITION SENSOR "A" CIRCUIT RANGE/PERFORMANCE

#### 1. OUTLINE OF DIAGNOSIS

Detect the malfunction of crankshaft position sensor output property. Judge NG when the number of crankshaft signal every 1 revolution becomes abnormal.

#### 2. COMPONENT DESCRIPTION

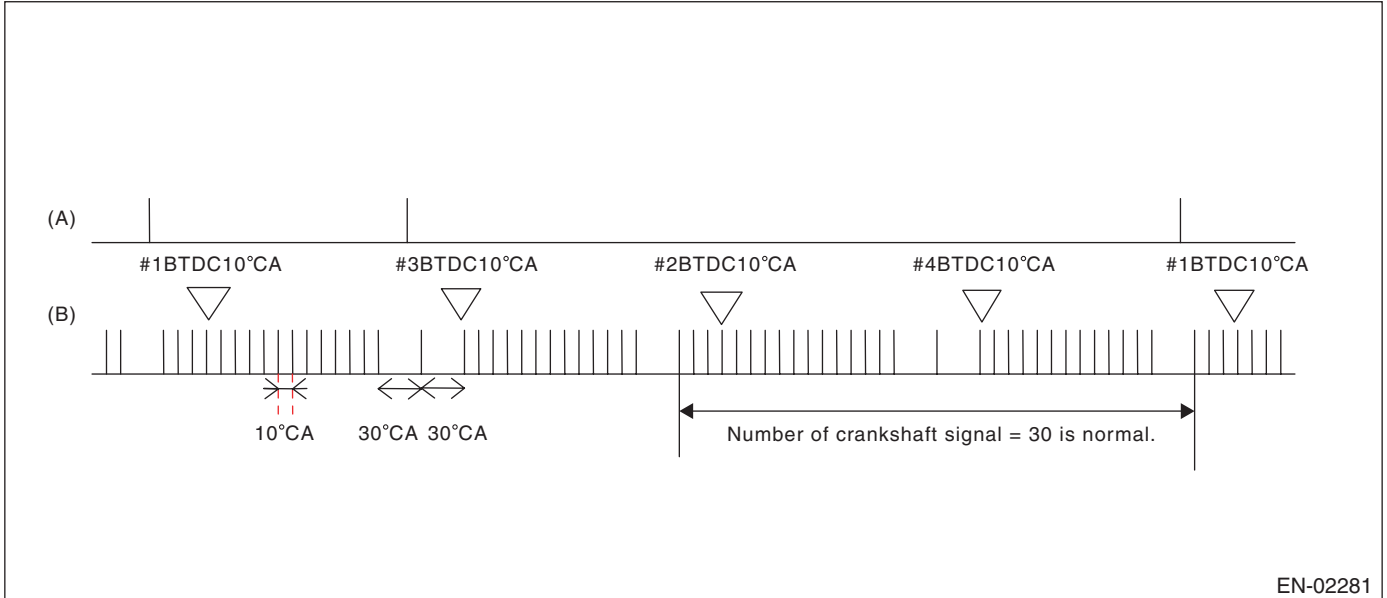

(A) Camshaft signal

(B) Crankshaft signal

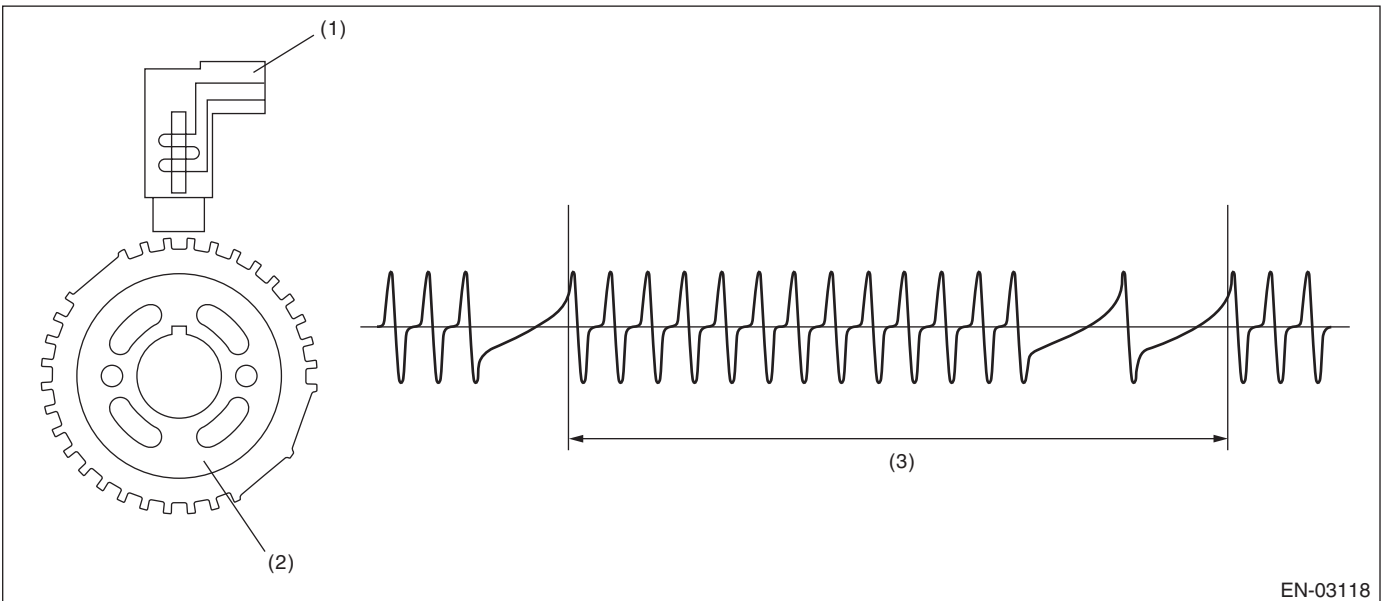

(1) Crankshaft position sensor

(2) Crank sprocket

(3) Crankshaft half-turn

#### 3. ENABLE CONDITION

Secondary Parameters	Enable Conditions
Battery voltage	$\geq 8 \text{ V}$
Engine speed	$< 4,000 \text{ rpm}$

# Diagnostic Trouble Code (DTC) Detecting Criteria

GENERAL DESCRIPTION

## 4. GENERAL DRIVING CYCLE

Perform the diagnosis continuously under 4,000 rpm engine speed.

## 5. DIAGNOSTIC METHOD

### • Abnormality Judgment

Judge NG when all the malfunction criteria below are completed more than 10 times in a row.

### Judgment Value

Malfunction Criteria	Threshold Value
Cylinder number distinction	Completed
Amount of crank sensor signal during 1 rev.	Not = 30

**Time Needed for Diagnosis:** 10 engine revs.

**Malfunction Indicator Light Illumination:** Illuminates when malfunction occurs in 2 continuous driving cycles.

### • Normality Judgment

Judge OK and clear the NG when the malfunction criteria below are completed.

### Judgment Value

Malfunction Criteria	Threshold Value
Cylinder number distinction	Completed
Amount of crank sensor signal during 1 rev.	= 30

## 6. DTC CLEAR CONDITION

- When the OK idling cycle was completed 40 times in a row
- When "Clear Memory" was performed

## 7. MALFUNCTION INDICATOR LIGHT CLEAR CONDITION

- When the OK driving cycle was completed 3 times in a row
- When "Clear Memory" was performed

## 8. FAIL SAFE

None

## 9. ECM OPERATION AT DTC SETTING

Memorize the freeze frame data. (For test mode \$02)

# Diagnostic Trouble Code (DTC) Detecting Criteria

## GENERAL DESCRIPTION

### BB:DTC P0340 CAMSHAFT POSITION SENSOR “A” CIRCUIT (BANK 1 OR SINGLE SENSOR)

#### 1. OUTLINE OF DIAGNOSIS

Detect the open or short circuit of camshaft position sensor. Judge NG when the number of camshaft signal remains to be abnormal.

#### 2. COMPONENT DESCRIPTION

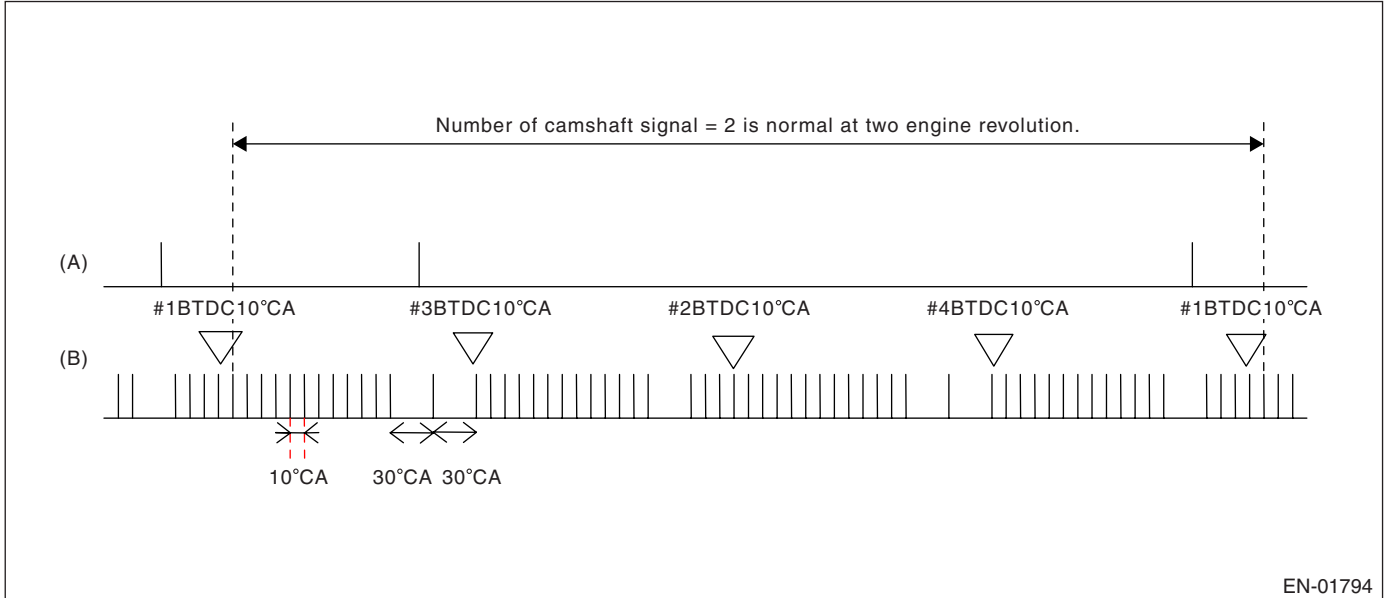

- (A) Camshaft signal
- (B) Crankshaft signal

#### 3. ENABLE CONDITION

Secondary Parameters	Enable Conditions
None	

#### 4. GENERAL DRIVING CYCLE

Always perform the diagnosis continuously.

#### 5. DIAGNOSTIC METHOD

##### • Abnormality Judgment

Judge NG when the engine speed continues 8 revolutions or more for the malfunction criteria below.

##### Judgment Value

Malfunction Criteria	Threshold Value
Voltage	≥ 8 V
Number of camshaft position sensor signal during 2 rev.	Except 2

**Time Needed for Diagnosis:** 8 rev.

**Malfunction Indicator Light Illumination:** Illuminates as soon as the malfunction occurs.

# Diagnostic Trouble Code (DTC) Detecting Criteria

GENERAL DESCRIPTION

## • Normality Judgment

Judge OK and clear the NG when the malfunction criteria below are completed.

### Judgment Value

Malfunction Criteria	Threshold Value
Voltage	$\geq 8$ V
Number of camshaft position sensor signal during 2 rev.	2

## 6. DTC CLEAR CONDITION

- When the OK idling cycle was completed 40 times in a row
- When "Clear Memory" was performed

## 7. MALFUNCTION INDICATOR LIGHT CLEAR CONDITION

- When the OK driving cycle was completed 3 times in a row
- When "Clear Memory" was performed

## 8. FAIL SAFE

None

## 9. ECM OPERATION AT DTC SETTING

Memorize the freeze frame data. (For test mode \$02)

# Diagnostic Trouble Code (DTC) Detecting Criteria

## GENERAL DESCRIPTION

### BC:DTC P0341 CAMSHAFT POSITION SENSOR "A" CIRCUIT RANGE/PERFORMANCE (BANK 1 OR SINGLE SENSOR)

#### 1. OUTLINE OF DIAGNOSIS

Detect the malfunction of camshaft position sensor output property. Judge NG when the camshaft line signal input timing is shifted from the crankshaft signal because of timing belt tooth chip, etc.

#### 2. COMPONENT DESCRIPTION

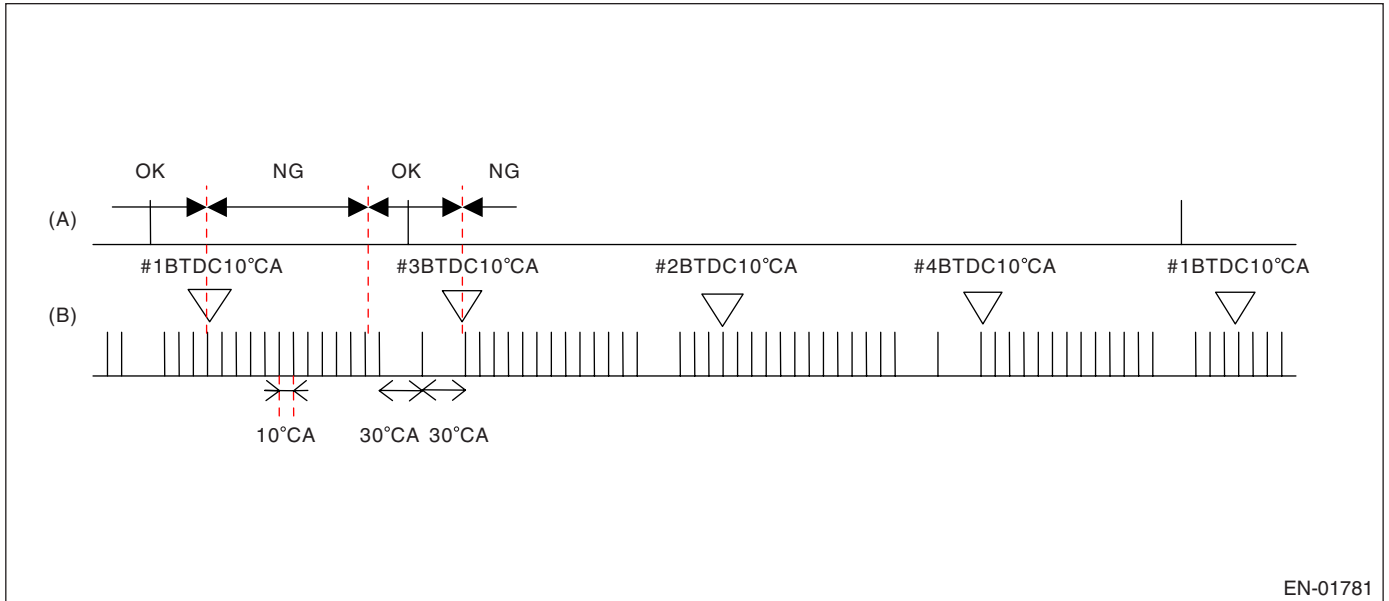

EN-01781

(A) Camshaft signal

(B) Crankshaft signal

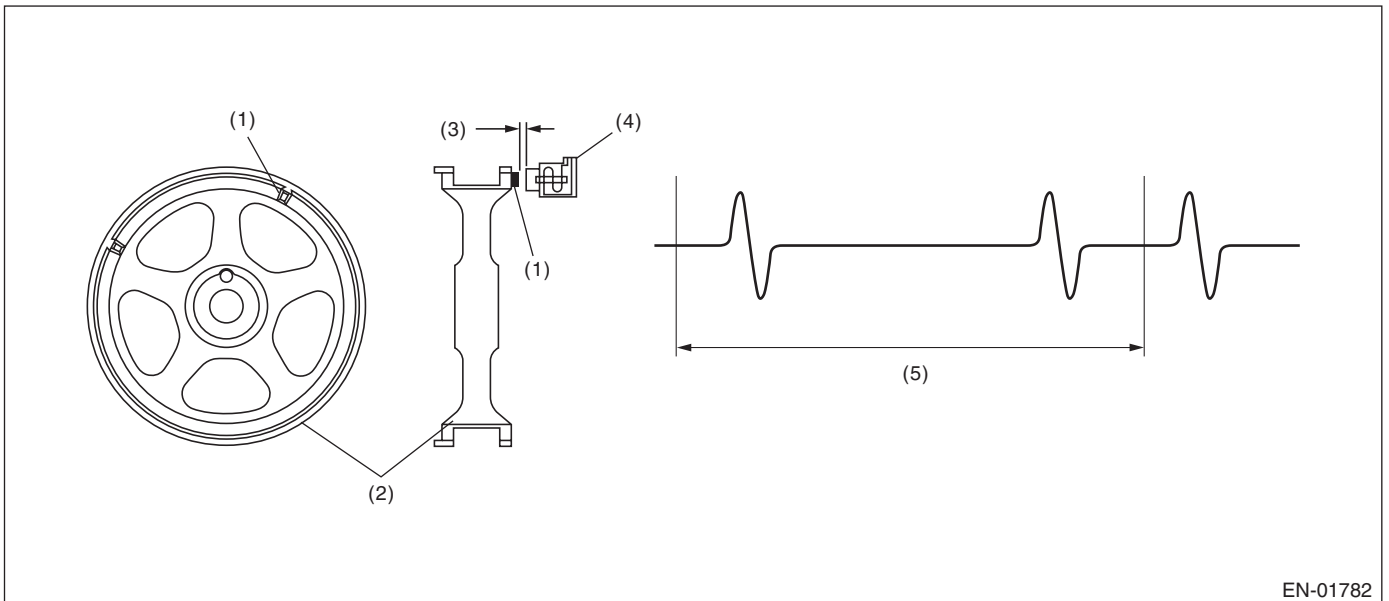

EN-01782

(1) Boss  
(2) Cam sprocket

(3) Air gap  
(4) Camshaft position sensor

(5) Camshaft one revolution (Engine two revolutions)

# Diagnostic Trouble Code (DTC) Detecting Criteria

GENERAL DESCRIPTION

## 3. ENABLE CONDITION

Secondary Parameters	Enable Conditions
Cylinder number distinction	Completed
Battery voltage	≥ 8 V
Engine speed	550 ←→ 1,000 rpm
Engine operation	In idle
Misfire	Not detect

## 4. GENERAL DRIVING CYCLE

Perform the diagnosis at idling continuously.

## 5. DIAGNOSTIC METHOD

Judge NG when the engine speed continues 4 revolutions for the malfunction criteria below. Judge OK and clear the NG when the malfunction criteria below are not completed.

### Judgment Value

Malfunction Criteria	Threshold Value
Position of camshaft position sensor signal	Not between BTDC 10°CA and BTDC 80°CA

**Time Needed for Diagnosis:**4 revs.

**Malfunction Indicator Light Illumination:**Illuminates when malfunction occurs in 2 continuous driving cycles.

## 6. DTC CLEAR CONDITION

- When the OK idling cycle was completed 40 times in a row
- When "Clear Memory" was performed

## 7. MALFUNCTION INDICATOR LIGHT CLEAR CONDITION

- When the OK driving cycle was completed 3 times in a row
- When "Clear Memory" was performed

## 8. FAIL SAFE

None

## 9. ECM OPERATION AT DTC SETTING

Memorize the freeze frame data. (For test mode \$02)

# Diagnostic Trouble Code (DTC) Detecting Criteria

## GENERAL DESCRIPTION

### BD:DTC P0400 EXHAUST GAS RECIRCULATION FLOW

#### 1. OUTLINE OF DIAGNOSIS

Detect the malfunction of EGR system.

Intake manifold pressure (negative pressure) is stable because the throttle valve is fully closed during the fuel shut-off in deceleration. In this case, the intake manifold pressure changes when EGR valve is opened or closed. Judge EGR system is OK or NG according to intake manifold pressure change amount.

#### 2. COMPONENT DESCRIPTION

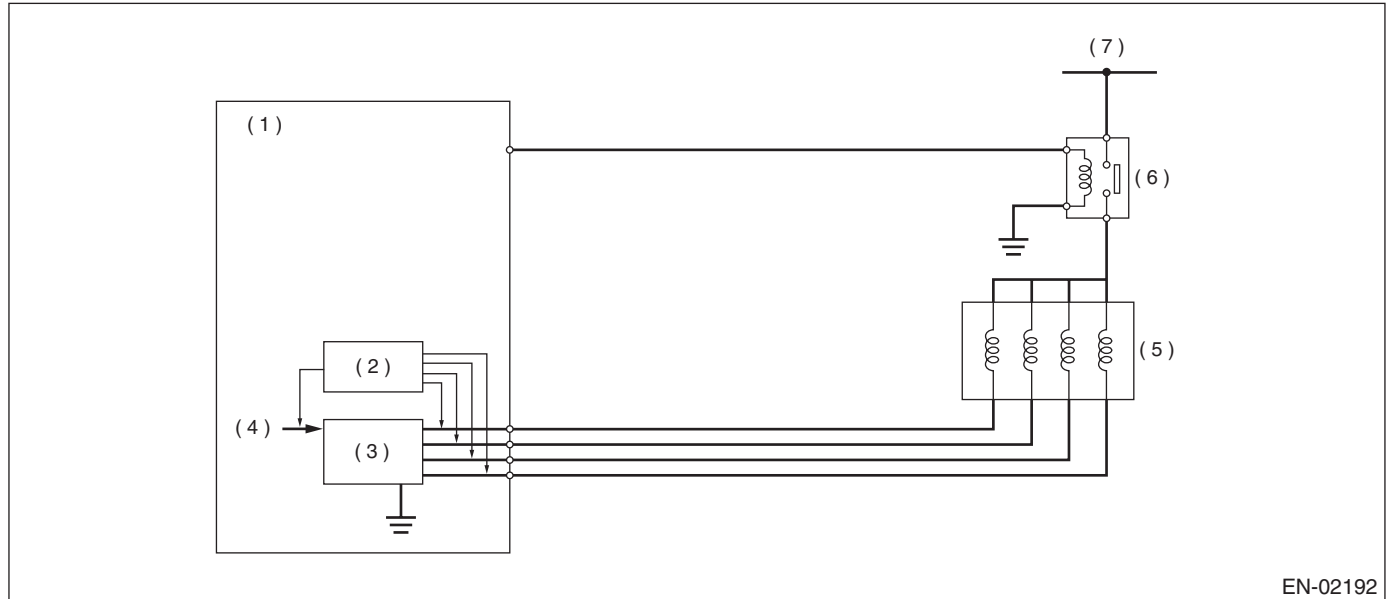

EN-02192

- |                       |                |                     |
|-----------------------|----------------|---------------------|
| (1) ECM               | (4) CPU        | (7) Battery voltage |
| (2) Detecting circuit | (5) EGR valve  |                     |
| (3) Switching circuit | (6) Main relay |                     |



# Diagnostic Trouble Code (DTC) Detecting Criteria

GENERAL DESCRIPTION

## 3. ENABLE CONDITION

Secondary Parameters	Enable Conditions
After engine starting	40 secs. or more
Engine coolant temperature	$\geq 75^{\circ}\text{C}$ (167 $^{\circ}\text{F}$ )
Engine speed	1,200 $\longleftrightarrow$ 2,950 rpm
Intake manifold pressure (absolute pressure)	$< 40.0$ kPa (300 mmHg, 11.81 inHg)
Estimated ambient temperature	$\geq 5^{\circ}\text{C}$ (41 $^{\circ}\text{F}$ )
Throttle position	$< 0.25^{\circ}$
Battery voltage	$> 10.9$ V
Atmospheric pressure	$\geq 75.0$ kPa (563 mmHg, 22.17 inHg)
Vehicle speed	$\geq 53$ km/h (33 MPH)
Fuel shut-off function	Operation
Neutral switch	OFF and 1 second after changing from "ON" to "OFF"
Load (air conditioner, power steering, lights, rear defroster, heater fan and radiator fan)	5 secs. or more no change

## 4. GENERAL DRIVING CYCLE

Perform the diagnosis only once at the fuel shut-off in deceleration in vehicle speed more than 53 km/h (approx. 33 MPH). Pay attention to vehicle speed and engine speed. (The diagnosis is not completed if vehicle speed and engine speed are out of condition due to deceleration.)

## 5. DIAGNOSTIC METHOD

Measure the pressure in the following procedures when the enable conditions are completed, and then diagnosis by calculating the result.

- (1) PMOF1 is equal to the intake manifold pressure at enable condition completed, and EGR target step is set to 50 steps (almost fully opened).
- (2) PMON is equal to the intake manifold pressure in 1 second after EGR target step is set 50 steps (when enable conditions are completed), and EGR target step is set to 0 step.
- (3) PMOF2 is equal to the intake manifold pressure in 1 second after EGR target step is set to 0 step (in 2 seconds after enable conditions are completed).

### • Abnormality Judgment

Judge NG when the malfunction criteria below is completed. Judge OK when not completed.

$\text{PMON} - (\text{PMOF1} + \text{PMOF2})/2 < 2.48$  kPa (18.63 mmHg, 0.733 inHg)

**Time Needed for Diagnosis:** Once

# Diagnostic Trouble Code (DTC) Detecting Criteria

## GENERAL DESCRIPTION

**Malfunction Indicator Light Illumination:** Illuminates when malfunction occurs in 2 continuous driving cycles.

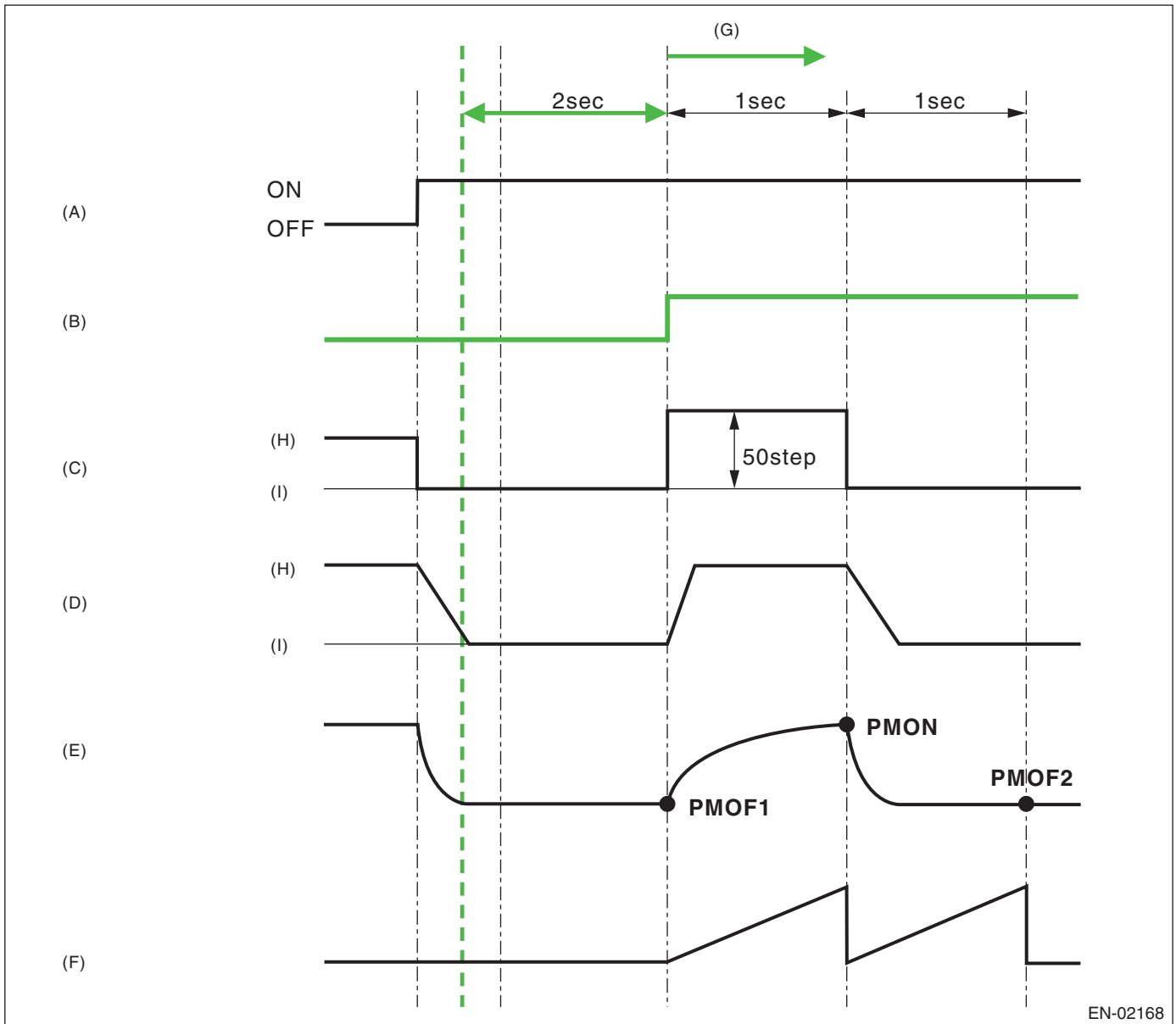

- (A) Fuel shut-off in deceleration
- (B) Diagnosis enable condition
- (C) EGR target step
- (D) EGR actual step

- (E) Intake manifold pressure (At normal condition)
- (F) Diagnosis mode timer
- (G) Diagnosis starts.

- (H) Open
- (I) Close

## 6. DTC CLEAR CONDITION

- When the OK idling cycle was completed 40 times in a row
- When "Clear Memory" was performed

## 7. MALFUNCTION INDICATOR LIGHT CLEAR CONDITION

- When the OK driving cycle was completed 3 times in a row
- When "Clear Memory" was performed

# Diagnostic Trouble Code (DTC) Detecting Criteria

GENERAL DESCRIPTION

## 8. FAIL SAFE

A/F main learning: Not allowed

Knock learning: Not allowed

EGR control: Not allowed to operate

## 9. ECM OPERATION AT DTC SETTING

- Memorize the freeze frame data. (For test mode \$02)
- Memorize the diagnosis value and trouble standard value. (For test mode \$06)

## BE:DTC P0420 CATALYST SYSTEM EFFICIENCY BELOW THRESHOLD (BANK 1)

### 1. OUTLINE OF DIAGNOSIS

Detect the deterioration of catalyst function.

Though the front oxygen sensor output would change slowly with a new catalyst, the sensor output with a deteriorated catalyst becomes high and the inversion time is shortened. For this reason, the catalyst diagnosis is carried out by monitoring the front oxygen sensor output and comparing it with the front A/F sensor output.

### 2. COMPONENT DESCRIPTION

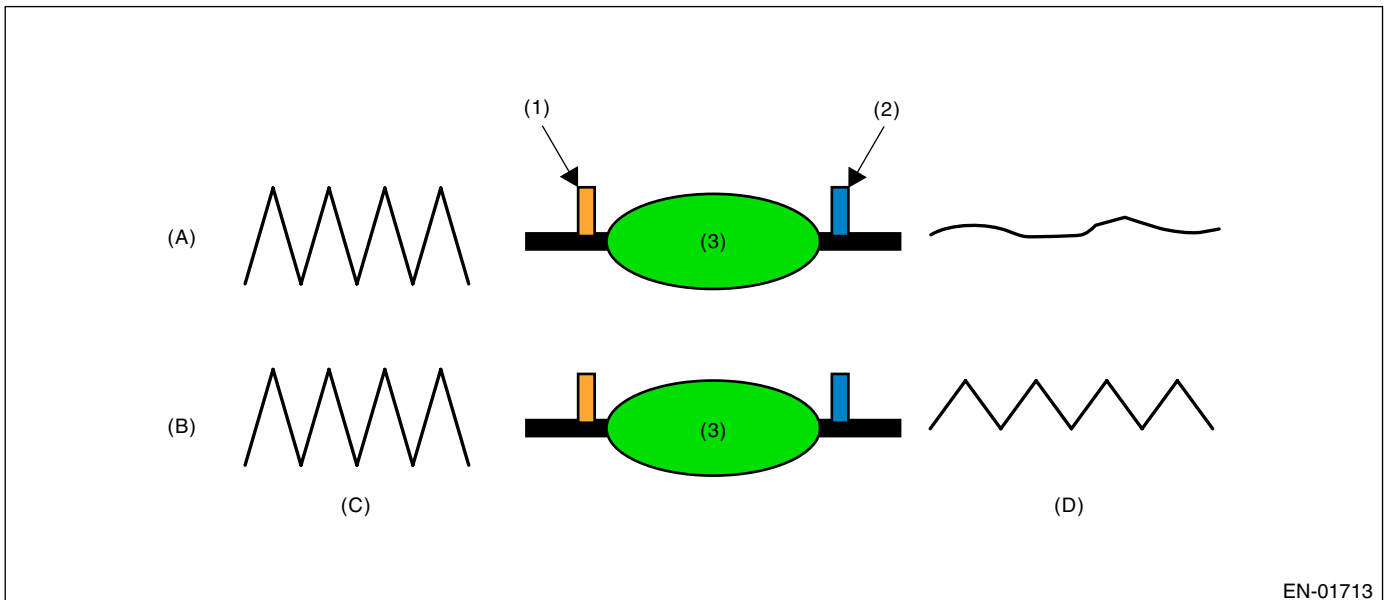

(1) Front oxygen (A/F) sensor

(2) Front oxygen sensor

(3) Catalyst

(A) Normal

(B) Deterioration

(C) Front oxygen (A/F) sensor waveform

(D) Front oxygen sensor waveform

# Diagnostic Trouble Code (DTC) Detecting Criteria

## GENERAL DESCRIPTION

### 3. ENABLE CONDITION

Secondary Parameters	Enable Conditions
Battery voltage	> 10.9 V
Atmospheric pressure	> 75.1 kPa (563 mmHg, 22.2 inHg)
Engine coolant temperature	≥ 70°C (158°F)
Catalyst warm-up counter on Map 2	≥ 8000
Misfire detection during 200 engine revs.	< 5 times
Learning value of evaporation gas density	≤ 0.20
Sub feedback	Operating
Evaporative system diagnostic	Not in operation
Difference between actual and target time lambda < 0.10	1,000 milliseconds or more
Vehicle speed	> 70 km/h (43.5 MPH)
Amount of intake air	10 ↔ 40 g (0.35 ↔ 1.41 oz)/s
Engine load change every 0.5 engine revs.	< 0.02 g/rev
Rear O <sub>2</sub> output change from below 660 mV to over	Experienced after fuel cut
After engine starting	≥ 205 seconds
Purge execution cumulative time	5 seconds or more

#### • Map 2

Add the following value every 512 milliseconds.

Amount of intake air (g (oz)/s)	0 (0)	3.2 (0.113)	6.4 (0.226)	9.6 (0.339)	12.8 (0.451)	16 (0.564)	19.2 (0.677)	22.4 (0.790)	25.6 (0.903)	28.8 (1.016)	32 (1.129)	35.2 (1.242)
Integrated value for warm-up counter	-5	-5	15	31	46	62	77	92	108	123	127	127

### 4. GENERAL DRIVING CYCLE

Perform the diagnosis once at the constant vehicle speed 70 km/h (43 MPH).

### 5. DIAGNOSTIC METHOD

After the malfunction criteria are completed, calculate cumulative value of front oxygen (A/F) sensor lambda deviation ( $\sum |(sglmd_n - sglmd_{n-1})|$ ) every 128 milliseconds and cumulative value of rear oxygen sensor output voltage deviation ( $\sum |(ro2sad_n - ro2sad_{n-1})|$ ).

Calculate the diagnosis value when the front oxygen (A/F) sensor output fluctuation value more than specified value.

Judge NG when the malfunction criteria below are completed, and judge OK when they are not completed.

#### Judgment Value

Malfunction Criteria	Threshold Value
$\sum  (ro2sad_n - ro2sad_{n-1})  / \sum  (sglmd_n - sglmd_{n-1}) $	> 1.0

**Time Needed for Diagnosis:** 30 — 55 seconds

**Malfunction Indicator Light Illumination:** Illuminates when malfunction occurs in 2 continuous driving cycles.

### 6. DTC CLEAR CONDITION

- When the OK idling cycle was completed 40 times in a row
- When “Clear Memory” was performed

# Diagnostic Trouble Code (DTC) Detecting Criteria

GENERAL DESCRIPTION

## 7. MALFUNCTION INDICATOR LIGHT CLEAR CONDITION

- When the OK driving cycle was completed 3 times in a row
- When "Clear Memory" was performed

## 8. FAIL SAFE

None

## 9. ECM OPERATION AT DTC SETTING

- Memorize the freeze frame data. (For test mode \$02)
- Memorize the diagnostic value and trouble standard value. (For test mode \$06)

## BF:DTC P0442 EVAPORATIVE EMISSION CONTROL SYSTEM LEAK DETECTED (SMALL LEAK)

### 1. OUTLINE OF DIAGNOSIS

Perform the diagnosis of leakage of fuels system and valve functions.

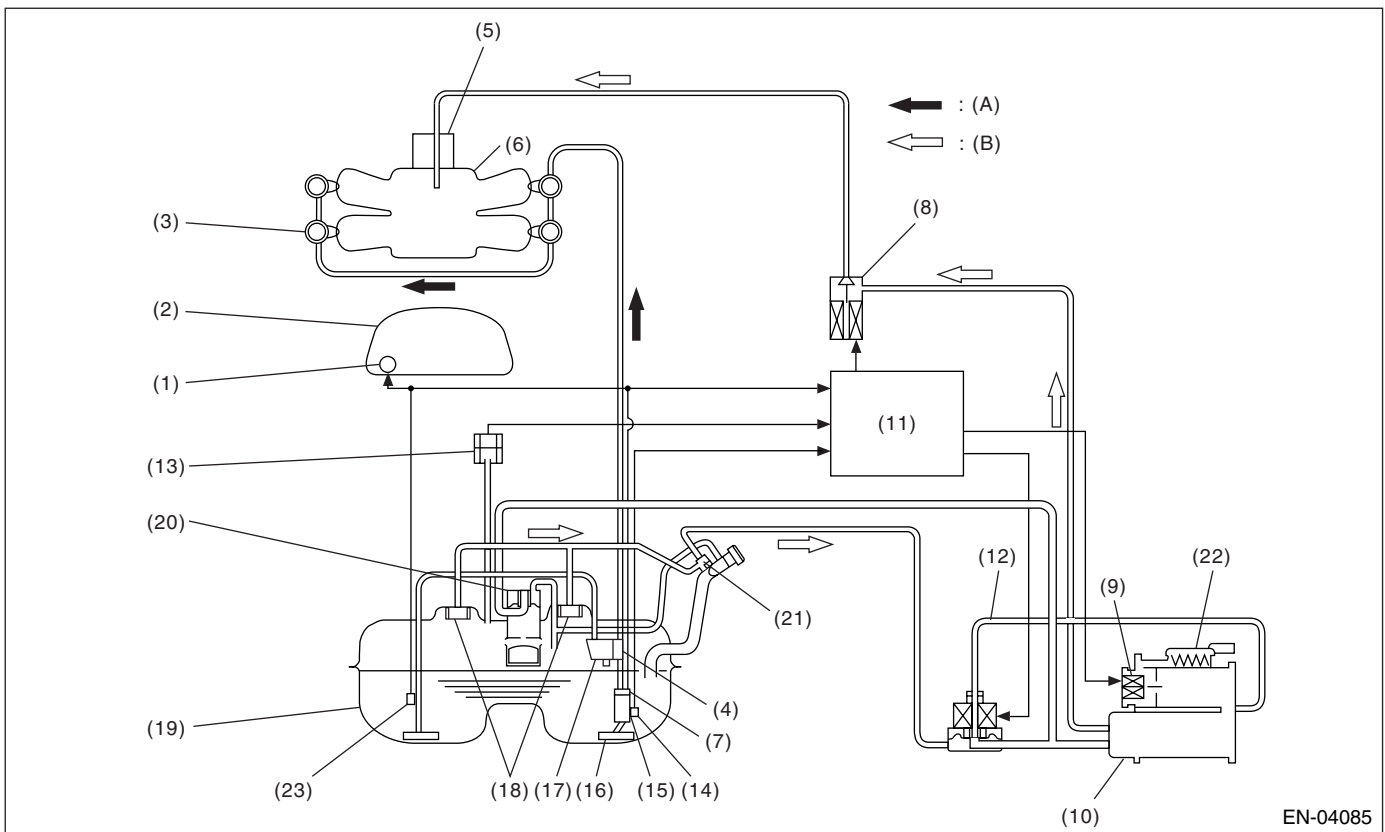

- |                                  |                                      |                            |
|----------------------------------|--------------------------------------|----------------------------|
| (1) Fuel gauge                   | (10) Canister                        | (19) Fuel tank             |
| (2) Combination meter            | (11) Engine control module (ECM)     | (20) Vent valve            |
| (3) Fuel injector                | (12) Pressure control solenoid valve | (21) Shut-off valve        |
| (4) Pressure regulator           | (13) Fuel tank pressure sensor       | (22) Drain filter          |
| (5) Throttle body                | (14) Fuel temperature sensor         | (23) Fuel sub level sensor |
| (6) Intake manifold              | (15) Fuel level sensor               |                            |
| (7) Fuel filter                  | (16) Fuel pump                       | (A) Fuel line              |
| (8) Purge control solenoid valve | (17) Jet pump                        | (B) Fuel evaporation line  |
| (9) Drain valve                  | (18) Fuel cut valve                  |                            |

# Diagnostic Trouble Code (DTC) Detecting Criteria

## GENERAL DESCRIPTION

In this system diagnosis, checking for leakage and valve function is conducted by changing the fuel tank pressure, and monitoring the pressure change using the fuel tank pressure sensor. 0.04 inch diagnosis is performed in the order of mode Z, mode A, mode B, mode C and mode D, and 0.02 inch diagnosis is performed in the order of mode A, mode B, mode C, mode D and mode E.

### • 0.04-inch Diagnosis

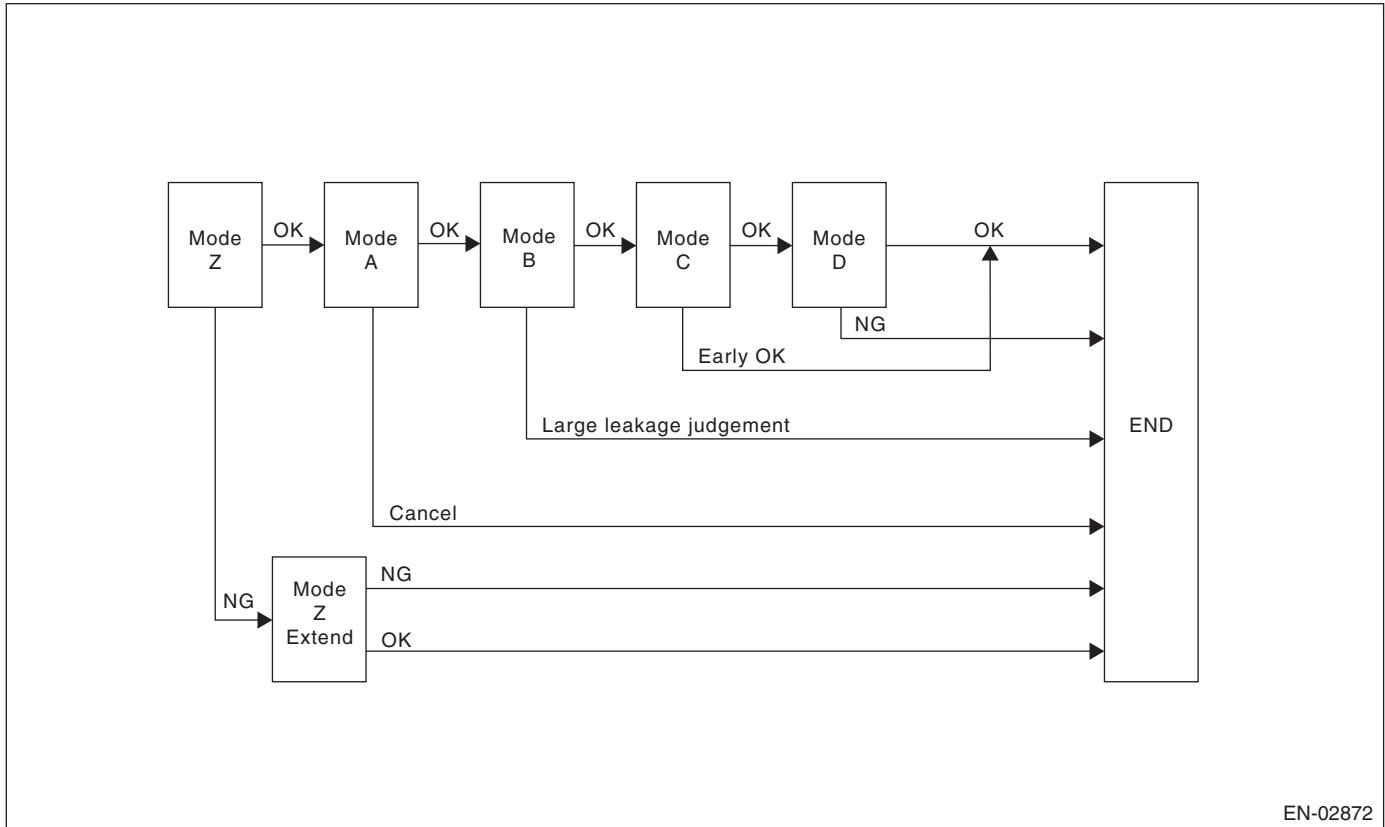

EN-02872

Mode	Mode Description	Diagnosis Period
Mode Z (CPC abnormal open diagnosis)	Diagnosis starts when there is a change in fuel tank pressure amount. Purge control solenoid valve open trouble diagnosis begins.	3 — 16 seconds
Mode A (Estimated evaporation amount)	Calculate the tank pressure change amount (P1).	10 seconds
Mode B (Sealed negative pressure/large leakage judgment)	Introduce the intake manifold pressure to the fuel tank and reduce the tank pressure to the desired value. If the tank pressure cannot be reduced, it is diagnosed as large leak.	5 — 25 seconds
Mode C (Pressure increase check/advanced OK judgment)	Wait until the tank pressure becomes the desired value (detection starting pressure of P2). If the tank pressure does not become the value, make advanced OK judgment.	1 — 15 seconds
Mode D (Negative pressure variation measurement/evaporation leakage diagnosis)	Calculate the tank pressure variation (P2), and obtain the diagnostic value using P1 of Mode A. Perform the evaporation leakage diagnosis using the diagnostic value.	10 seconds

# Diagnostic Trouble Code (DTC) Detecting Criteria

GENERAL DESCRIPTION

## • Mode Table for Evaporative Emission Control System Diagnosis

Mode	Behavior of tank internal pressure under normal conditions	Diagnostic item	DTC
Mode Z	Nearly same as atmospheric pressure (equivalent pressure of 0 kPa (0 mmHg, 0 inHg))	CPC is judged to be stuck open.	P0457
Mode A	Pressure is in proportion to amount of evaporative emission.		
Mode B	Negative pressure is formed due to intake manifold negative pressure	Large leakage	P0457
Mode C	Target pressure is reached.		None
Mode D	Pressure change is small.	EVAP system is judged to have large leak [1.0 mm (0.04 in)].	P0442

## • 0.02-inch Diagnosis

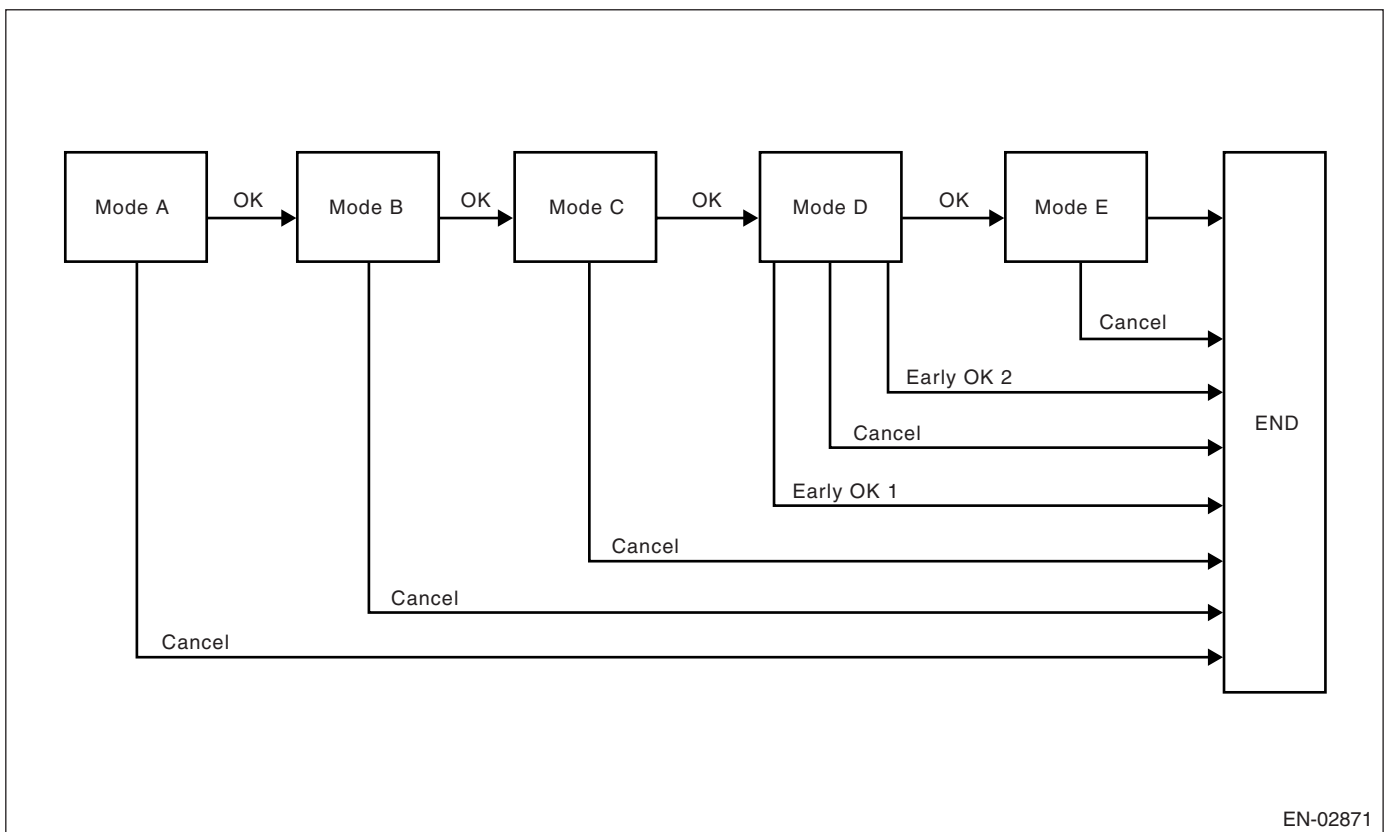

EN-02871

Mode	Mode Description	Diagnosis Period
Mode A (0 point correction)	Wait until the tank pressure returns to 0 point (near 0 mm Hg) when tank pressure is high.	0 s — 12 s
Mode B (Negative pressure Introduction)	Introduce the intake manifold pressure into fuel tank to reduce the tank pressure to the desired value.	0 s — 27 s
Mode C (Holding negative pressure)	Wait until the tank pressure becomes the desired value (detection starting pressure of P2).	0 s — 20 s
Mode D (Calculation of negative pressure variation)	Calculate the time that takes the tank pressure to return to detection completing pressure of P2. When the tank pressure does not return to the detection completing pressure of P2, make advanced OK judgment.	0 s — 200 s
Mode E (Calculation of yielded evaporation amount)	Calculate the yielded evaporation amount (P1).	0 s — 280 s

# Diagnostic Trouble Code (DTC) Detecting Criteria

## GENERAL DESCRIPTION

### 2. COMPONENT DESCRIPTION

#### • Pressure Control Solenoid Valve

PCV controls the fuel tank pressure to be equal to the atmospheric air pressure.

Normally, the solenoid is set to OFF. And the valve opens and closes mechanically in accordance with the pressure difference between tank and atmospheric air, or tank and canister.

The valve is forcibly opened by setting the solenoid to ON at the time of diagnosis.

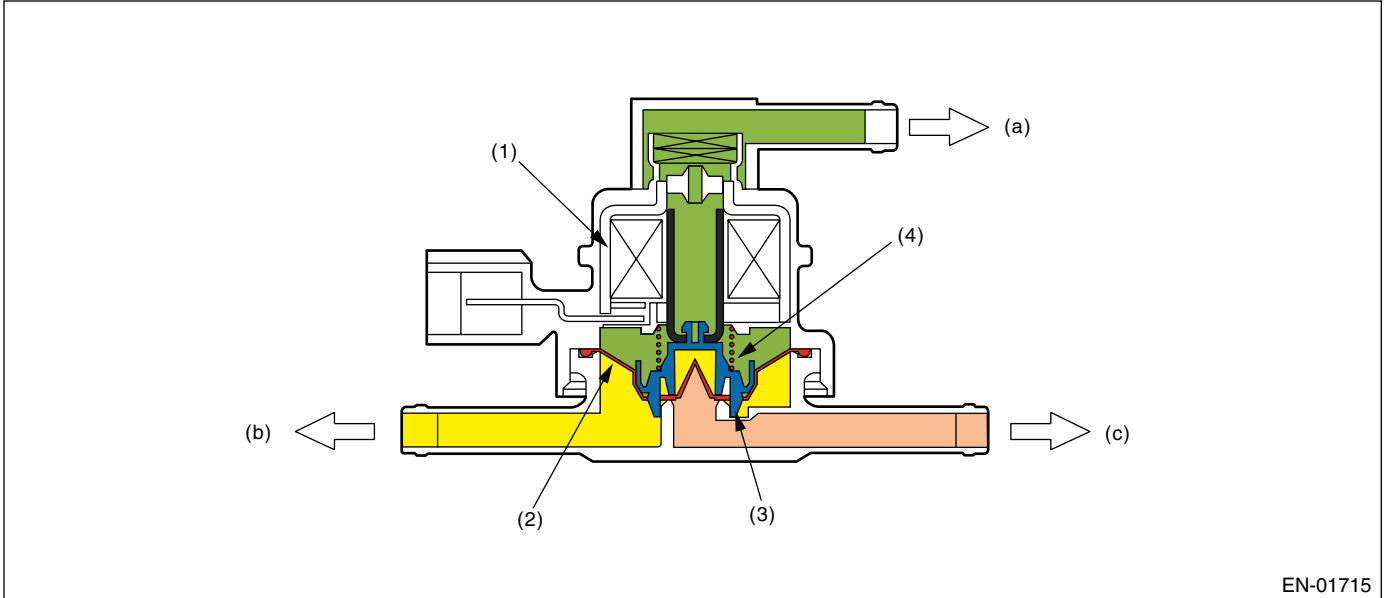

- |               |                          |
|---------------|--------------------------|
| (1) Solenoid  | (a) Atmospheric pressure |
| (2) Diaphragm | (b) Fuel tank            |
| (3) Valve     | (c) Canister             |
| (4) Spring    |                          |



# Diagnostic Trouble Code (DTC) Detecting Criteria

GENERAL DESCRIPTION

## • Valve Operation and Air Flow

In the figure below, divided by the diaphragm, the part above X is charged with atmospheric air pressure, and the part below X is charged with tank pressure. Also, the part above Y is charged with tank pressure, and the part below Y is charged with canister pressure.

If the atmospheric air pressure port is A, tank pressure port is B, and canister pressure port is C, the air flows according to pressure difference from each port as shown in the table below.

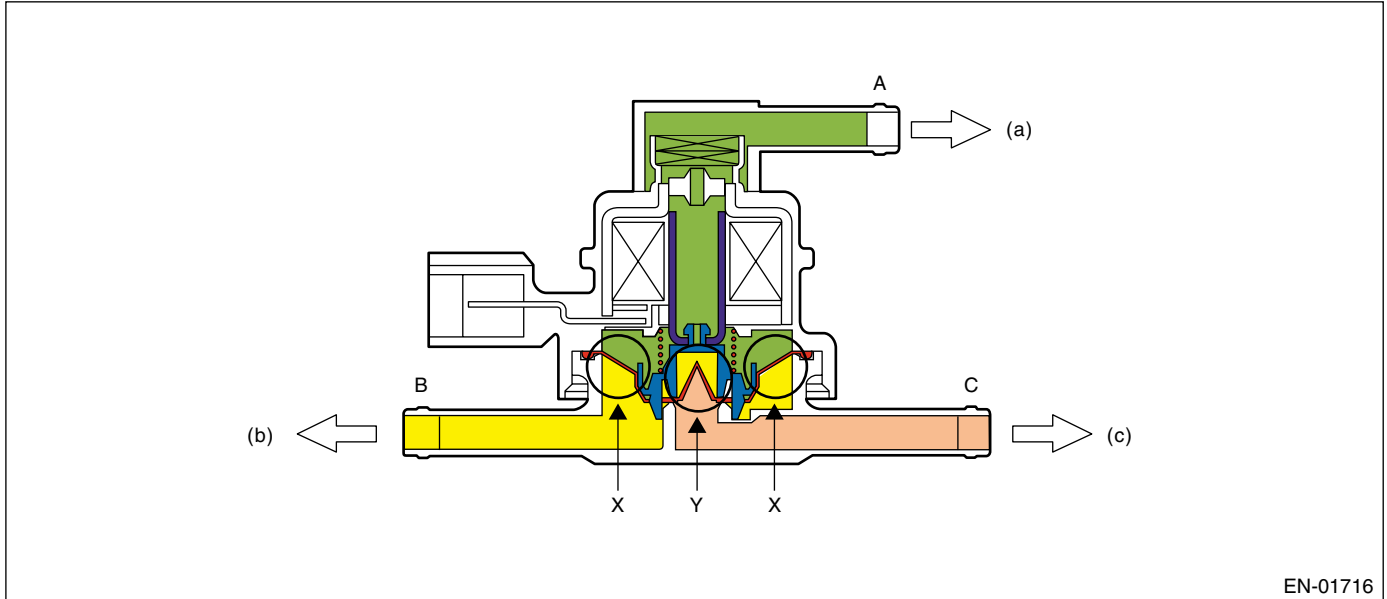

(a) Atmospheric pressure

(b) Fuel tank

(c) Canister

Condition of pressure	Flow
$A < B$ (solenoid OFF)	$B \rightarrow C$
$B < C$ (solenoid OFF)	$C \rightarrow B$
Solenoid ON	$B \leftrightarrow C$

### When $A < B$ (Solenoid OFF)

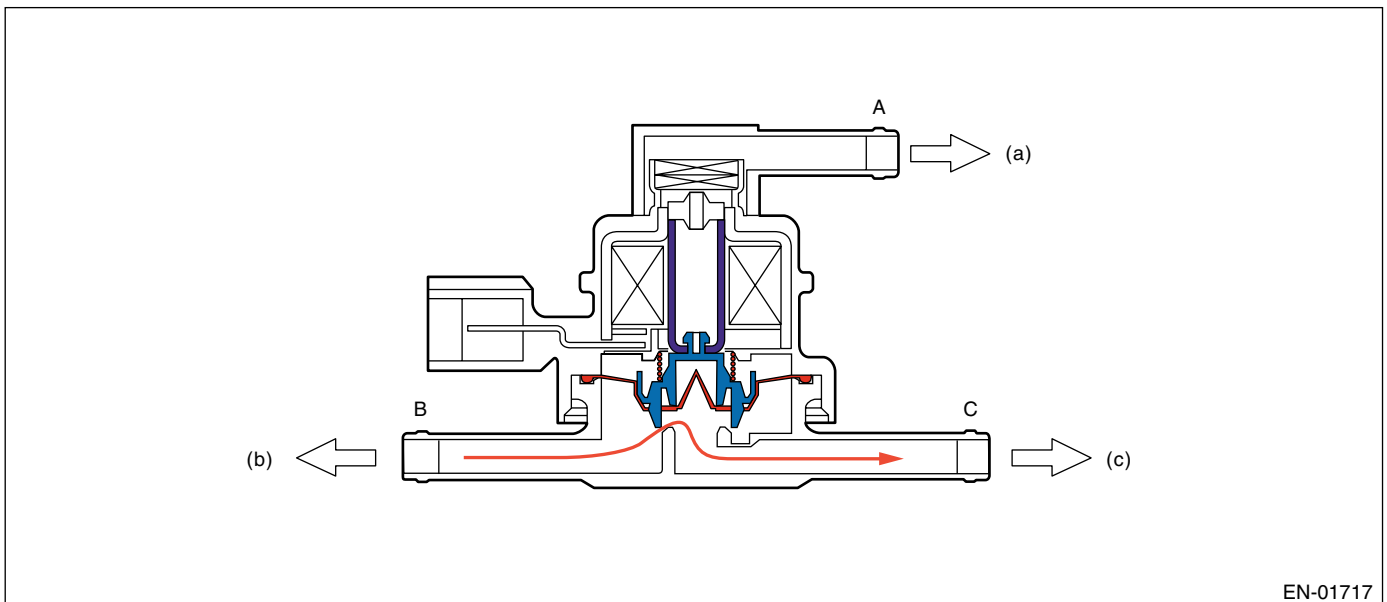

(a) Atmospheric pressure

(b) Fuel tank

(c) Canister

# Diagnostic Trouble Code (DTC) Detecting Criteria

## GENERAL DESCRIPTION

### When $B < C$ (Solenoid OFF)

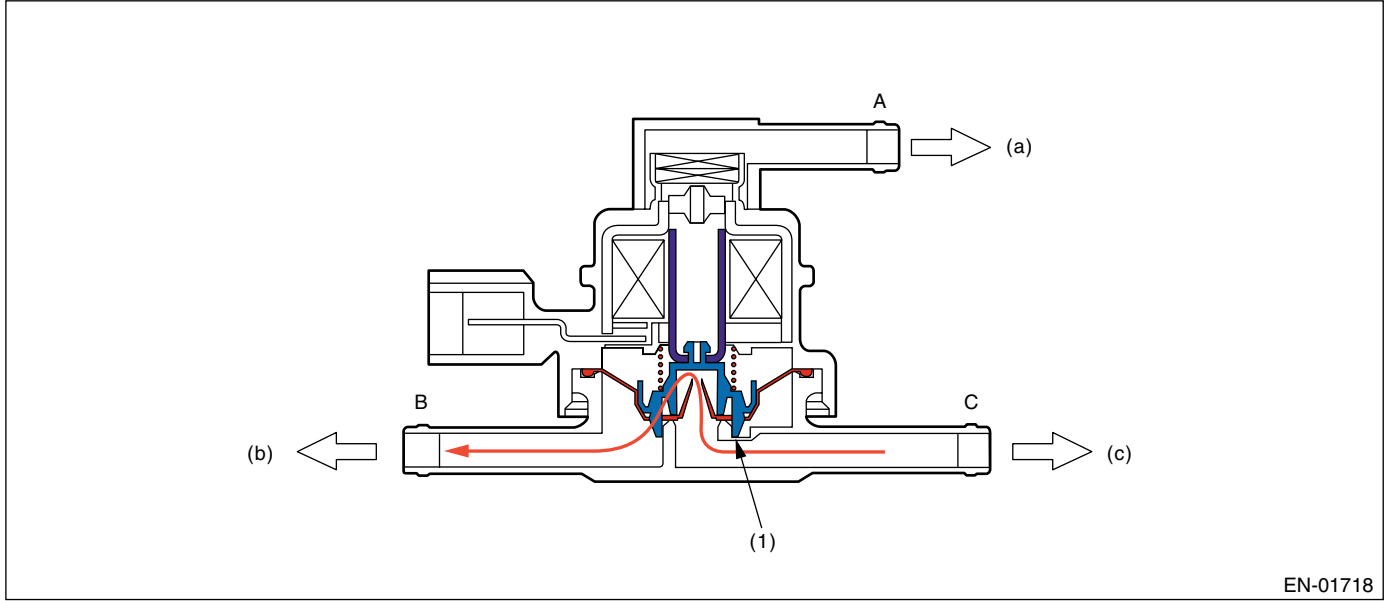

- (1) Valve
- (a) Atmospheric pressure
- (b) Fuel tank
- (c) Canister

### When Solenoid is ON

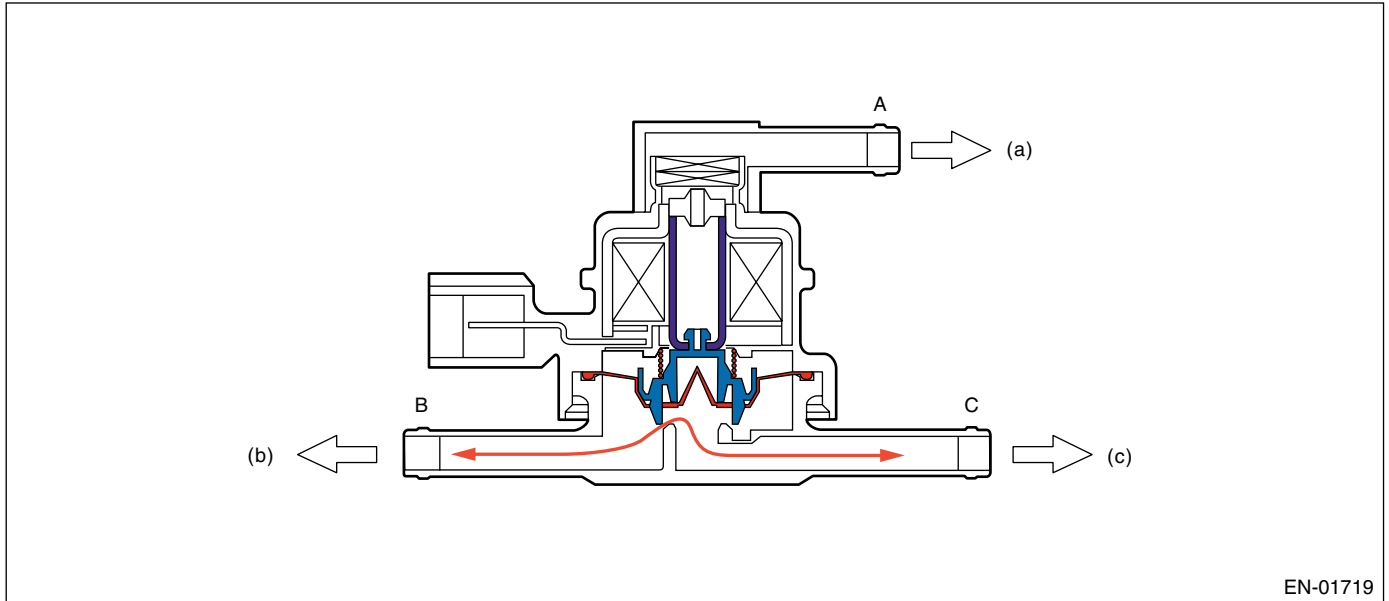

- (a) Atmospheric pressure
- (b) Fuel tank
- (c) Canister

# Diagnostic Trouble Code (DTC) Detecting Criteria

GENERAL DESCRIPTION

## • Drain valve

Drain valve controls the ambient air to be introduced to the canister.

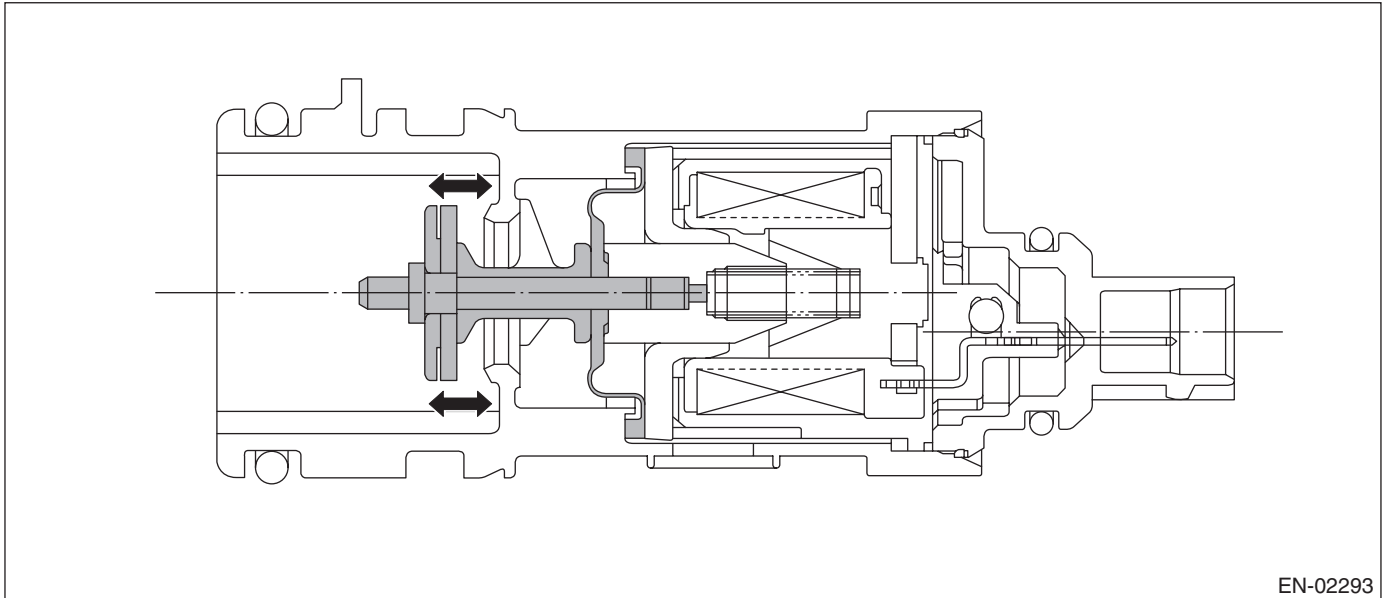

EN-02293

## 3. ENABLE CONDITION

### • 0.04-inch Diagnosis

Secondary Parameters	Enable Conditions
Battery voltage	$\geq 10.9 \text{ V}$
Barometric pressure	$\geq 75.1 \text{ kPa}$ (563 mmHg, 22.17 inHg)
Cumulative time of canister purge	120 seconds or more
After engine starting	856 seconds or more
Learning value of evaporation gas density	$\leq 0.08$
Engine speed	1,050 $\leftrightarrow$ 6,000 rpm
Fuel tank pressure	$\geq -4.00 \text{ kPa}$ (-30 mmHg, -1.18 inHg)
Intake manifold vacuum (relative pressure)	$< -26.7 \text{ kPa}$ (-200 mmHg, -7.87 inHg)
Vehicle speed	$\geq 32 \text{ km/h}$ (20 MPH)
Fuel level	9 $\leftrightarrow$ 51 $\varnothing$ (2.38 $\leftrightarrow$ 13.47 US gal, 1.98 $\leftrightarrow$ 11.22 Imp gal)
Closed air/fuel ratio control	In operation
Fuel temperature	-10 $\leftrightarrow$ 45°C (14 $\leftrightarrow$ 113°F)
Intake air temperature	$\geq -10^\circ\text{C}$ (14°F)
Pressure change per second	$< 0.23 \text{ kPa}$ (1.7 mmHg, 0.07 inHg)
Min. pressure change per second – Max. pressure change per second	$< 0.23 \text{ kPa}$ (1.7 mmHg, 0.07 inHg)
Fuel level change	$< 2.5 \varnothing / 128$ milliseconds (0.66 US gal/128 milliseconds, 0.55 Imp gal/128 milliseconds)
Air fuel ratio	0.76 — 1.25

# Diagnostic Trouble Code (DTC) Detecting Criteria

## GENERAL DESCRIPTION

### • 0.02-inch Diagnosis

Secondary Parameters	Enable Conditions
(At starting a diagnosis)	
Evaporation diagnosis	Not completed
Battery voltage	≥ 10.9 V
Atmospheric pressure	≥ 75.1 kPa (563 mmHg, 22.2 inHg)
Since last incomplete diagnosis event of 0.02-inch leakage	
Cancelled at mode A	> 120 seconds
Cancelled other than at mode A	> 600 seconds
Cumulative time of canister purge	120 seconds or more
After engine starting	120 second or more
Fuel temperature	-10 ↔ 70°C (14 ↔ 158°F)
Fuel level	9 ↔ 51 ℓ (2.38 ↔ 13.47 US gal, 1.98 ↔ 11.22 Imp gal)
Intake manifold vacuum (relative pressure)	< -8.0 kPa (-60 mmHg, -2.36 inHg)
Fuel tank pressure	-0.67 — 1.43 kPa (-5 — 10.7 mmHg, -0.20 — 0.42 inHg)
Vehicle speed	≥ 30 km/h (19 MPH)
Closed air/fuel ratio control	In operation
Engine speed	550 ↔ 6,000 rpm
(During diagnosis)	
Fuel level change	≤ Value of Map
Pressure change per second	< 0.06 kPa (0.44 mmHg, 0.02 inHg)
Min. tank pressure change per second – Max. tank pressure change per second	< 0.07 kPa (0.51 mmHg, 0.02 inHg)
Tank pressure change per second	≤ 0.1 kPa (0.75 mmHg, 0.03 inHg)
Pressure change (Mode D)	-0.48 ↔ 0.32 kPa (-3.6 ↔ 2.4 mmHg, -0.14 ↔ 0.09 inHg)
Pressure change (Mode E)	-0.32 ↔ 0.32 kPa (-2.4 ↔ 2.4 mmHg, -0.09 ↔ 0.09 inHg)

### Map

Fuel level (ℓ, US gal, Imp gal)	0	10, 2.64, 2.2	20, 5.28, 4.4	30, 7.93, 6.6	40, 10.57, 8.8	50, 13.21, 11	60, 15.85, 13.2
Variation (ℓ, US gal, Imp gal)	4.2, 1.11, 0.92	4.2, 1.11, 0.92	4.1, 1.08, 0.9	4.0, 1.06, 0.88	3.9, 1.03, 0.86	3.8, 1.0, 0.84	3.8, 1.0, 0.84

# Diagnostic Trouble Code (DTC) Detecting Criteria

GENERAL DESCRIPTION

## 4. GENERAL DRIVING CYCLE

### • 0.04-inch Diagnosis

- Perform the diagnosis only once in more than 856 seconds after the engine start at the constant driving speed of 32 km/h (20 MPH) or more.
- Pay attention to the fuel temperature and fuel level.

### • 0.02-inch Diagnosis

- Perform diagnosis in more than 770 seconds after engine start at the constant speed of 68 km/h (42 MPH) or more, and judged OK or NG.
- If not judged OK or NG, repeat the diagnosis.
- Pay attention to the fuel level.

## 5. DIAGNOSTIC METHOD

### • Purge control solenoid valve open malfunction diagnosis

DTC

P0457 Evaporative Emission Control System Leak Detected (fuel cap loose/off)

#### Purpose of Mode Z

When performing the leakage diagnosis of EVAP system, CPC has to operate normally. Therefore, mode Z is used to diagnose the CPC open fixation.

If the CPC open fixation trouble is detected, the EVAP system leakage diagnosis is cancelled.

#### Diagnostic method

CPC functional diagnosis is performed by monitoring the tank pressure in Mode Z.

#### Normality Judgment

Judge OK when the following criteria are satisfied in 3 seconds after Mode Z started, and change to Mode A.

#### Judgment Value

Malfunction Criteria	Threshold Value	DTC
(Tank pressure when Mode Z started) — (Tank pressure when Mode Z finished)	$\leq 0.4$ kPa (3 mmHg, 0.12 inHg)	P0457

### • Normal Operation

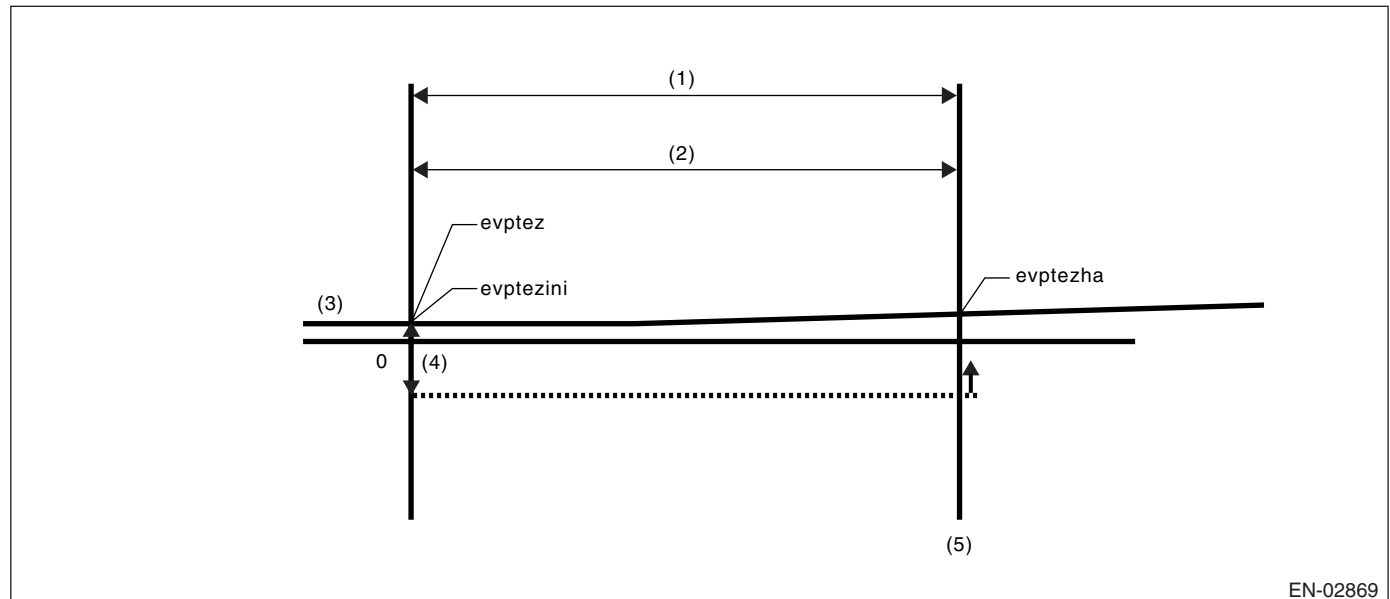

EN-02869

- |               |                                   |                  |
|---------------|-----------------------------------|------------------|
| (1) Mode Z    | (3) Fuel tank pressure            | (5) OK judgement |
| (2) 3 seconds | (4) 0.4 kPa (3.0 mmHg, 0.12 inHg) |                  |

- $evptez - evptezha \leq 0.4$  kPa (3.0 mmHg, 0.12 inHg)
  - $evptezini - evptezha \leq 0.4$  kPa (3.0 mmHg, 0.12 inHg)
- Judge normal when both calculations are completed.

# Diagnostic Trouble Code (DTC) Detecting Criteria

## GENERAL DESCRIPTION

---

### Abnormality Judgment

If OK judgment cannot be made, extend Mode Z 16 seconds more, and judge NG when the criteria below are completed in 16 seconds.

### Judgment Value

Malfunction Criteria	Threshold Value	DTC
(Tank pressure when Mode Z started) – (Tank pressure when Mode Z finished)	> 0.6 kPa (4.5 mmHg, 0.18 inHg)	P0457
Tank pressure when Mode Z started	≤ 1.43 kPa (10.7 mmHg, 0.42 inHg)	
Time for no fuel rolling of 2 0 or more	≥ 40 seconds	

**Time Needed for Diagnosis:** 16 seconds

**Malfunction Indicator Light Illumination:** Illuminates when malfunction occurs in 2 continuous driving cycles.

Finish the Evap. diagnosis when making NG judgment for purge control solenoid valve open fixation.

Cancel the Evap. diagnosis when the OK/NG judgment for purge control solenoid valve open fixation cannot be made in Mode Z.

# Diagnostic Trouble Code (DTC) Detecting Criteria

GENERAL DESCRIPTION

## • Purge Control Solenoid Valve Open Fixation

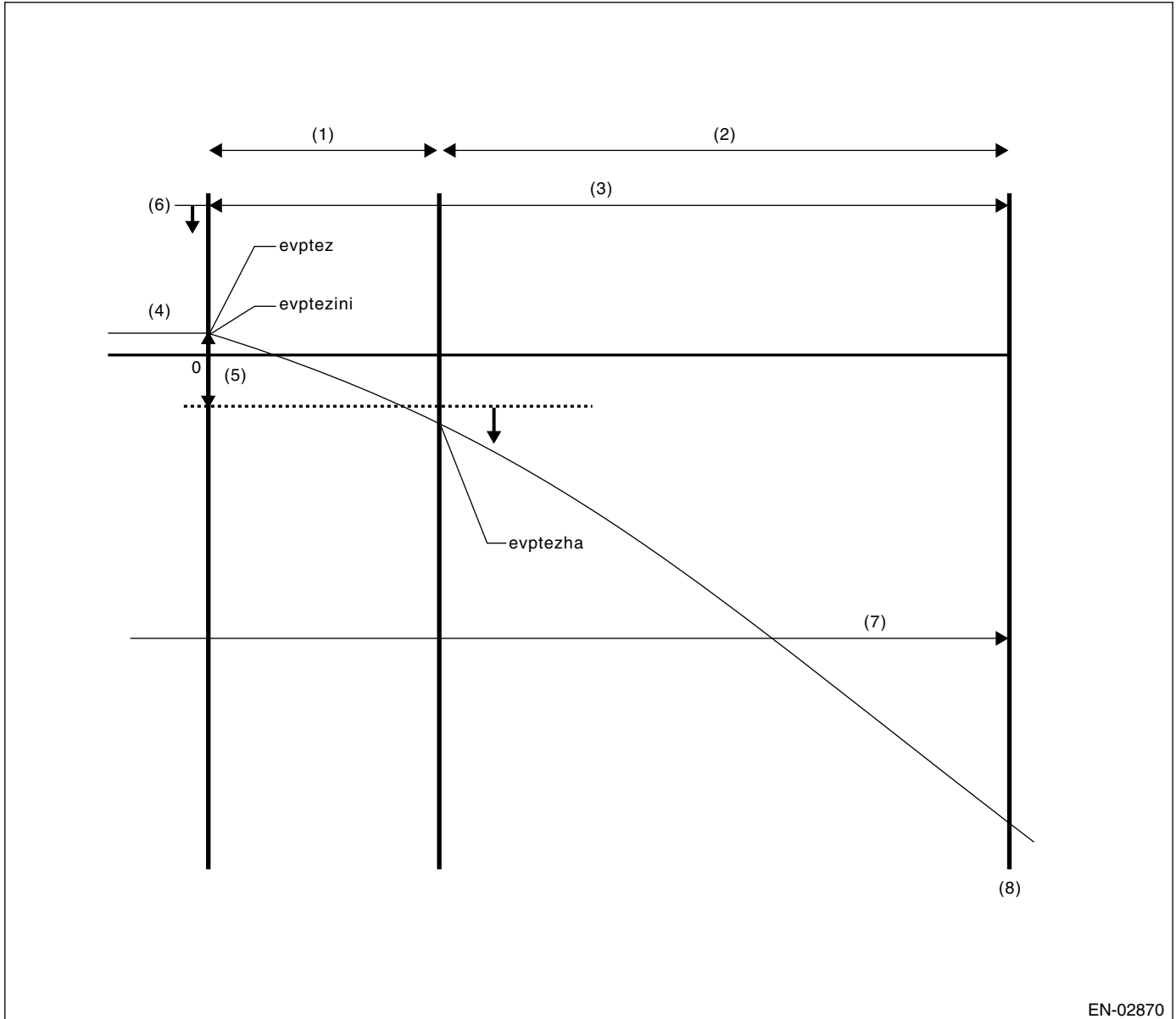

EN-02870

- |                     |                                     |  |
|---------------------|-------------------------------------|--|
| (1) Mode Z          | (4) Fuel tank pressure              | (7) No fuel rolling for more than 40 seconds |
| (2) Extended mode Z | (5) 0.87 kPa (6.5 mmHg, 0.26 inHg)  | (8) NG judgement                             |
| (3) 16 seconds      | (6) 1.43 kPa (10.7 mmHg, 0.42 inHg) |  |

- $evptezini, evptez \leq 1.43 \text{ kPa (10.7 mmHg, 0.42 inHg)}$
  - $evptez - evptezha \leq 0.87 \text{ kPa (6.5 mmHg, 0.26 inHg)}$
  - $evptezini - evptezha \leq 0.87 \text{ kPa (6.5 mmHg, 0.26 inHg)}$
  - No fuel rolling of above 2  $\varnothing$  (0.53 US gal, 0.44 Imp gal) for more than 40 seconds.
- Judge normal when all the calculations are completed.

### • Leak Diagnosis

DTC

P0442 Evaporative Emission Control System Leak Detected (small leak)

P0457 Evaporative Emission Control System Leak Detected (fuel cap loose/off)

# Diagnostic Trouble Code (DTC) Detecting Criteria

## GENERAL DESCRIPTION

### • Diagnostic method

- The diagnostic method consists of creating a sealed vacuum in the fuel tank and then determining the presence of leakage from the speed at which the tank internal pressure returns to atmospheric pressure.
- The diagnosis is divided into the following five phases.

#### Mode A: (Estimation of evaporation gas yield)

The amount of change of tank pressure (P1) in Mode A is calculated. After calculating P1, change to Mode B.

#### Mode B: (Seal negative pressure)

Introduce the negative pressure in the intake manifold to the tank.

Approx. 0 → -1.4 kPa (0 → -10.5 mmHg, 0 → -0.41 inHg)

When the pressure above (desired negative pressure) is reached, Mode C is entered.

In this case, if the tank pressure does not become the desired negative pressure, judge that there is a large leakage in the system, finish the Evap. diagnosis when judging large leak (10 or 25 seconds).

### • Abnormality Judgment

Judge NG (large leak) when the criteria below are completed in the specified time.

#### Judgment Value

Malfunction Criteria	Threshold Value	DTC
Time before reaching desired negative pressure	≥ 25 seconds	P0457
Or time for Mode B	≥ 10 seconds	
(Min. value of tank pressure during Mode B) – (Tank pressure when Mode B started)	< -0.53 kPa (-4 mmHg, -0.16 inHg)	

#### Mode C: (Check increasing pressure)

Stop the introduction of negative pressure. (Wait until the tank pressure returns to the start level of P2 calculation.)

Change to Mode D when the tank pressure returns to the start level of P2 calculation.

Judge immediate OK and change to Mode E when it does not return in spite of spending the specified time.

Tank pressure when P2 calculation started	Time for immediate OK judgment
-1.3 kPa (-9.75 mmHg, -0.38 inHg)	15 seconds

#### Mode D: (Measurement of negative pressure changes)

Monitor the pressure variation in the tank in Mode Z. In this case, the tank pressure increases, that is, the pressure becomes as high as the atmospheric air pressure, because evaporator is generated. However, if any leakage exists, the pressure increases additionally in proportion to this leakage. The pressure variation of this tank is P2.

After calculating P2, perform following small leak diagnosis.

#### After Mode D

Assigning P1 and P2, which are tank variations measured in Mode A and Mode D, to the formula below, judge the small leakage of the system. If the measured judgment value exceeds the threshold value, it is judged to be malfunction.

### • Abnormality Judgment

Judge NG when the criteria below are completed. Judge OK when not completed and clear the NG.

#### Judgment Value

Malfunction Criteria	Threshold Value	DTC
P2 – 1.5 × P1 P2: Change of tank pressure within 10 seconds on Mode D P1: Change of tank pressure within 10 seconds on Mode A	> Value on map 7. *Threshold value: Map (Fuel level vs Tank temperature)	P0442

\*1.5: Compensation value of the amount of evaporator occurrence. (Because evaporator increases more when becoming negative pressure.)



# Diagnostic Trouble Code (DTC) Detecting Criteria

GENERAL DESCRIPTION

## Map 7 Limit of malfunction criteria as Evap. diagnosis.

Fuel temperature vs Fuel level	5°C (41°F)	15°C (59°F)	25°C (77°F)	35°C (95°F)	45°C (113°F)
10 L (2.6 US gal, 2.2 Imp gal)	0.49 kPa (3.68 mmHg, 0.145 inHg)	0.49 kPa (3.68 mmHg, 0.145 inHg)	0.53 kPa (3.95 mmHg, 0.156 inHg)	0.54 kPa (4.07 mmHg, 0.160 inHg)	0.56 kPa (4.17 mmHg, 0.164 inHg)
20 L (5.3 US gal, 4.4 Imp gal)	0.50 kPa (3.77 mmHg, 0.148 inHg)	0.51 kPa (3.79 mmHg, 0.149 inHg)	0.53 kPa (4.01 mmHg, 0.158 inHg)	0.56 kPa (4.17 mmHg, 0.164 inHg)	0.57 kPa (4.27 mmHg, 0.168 inHg)
30 L (7.9 US gal, 6.6 Imp gal)	0.51 kPa (3.85 mmHg, 0.152 inHg)	0.52 kPa (3.9 mmHg, 0.154 inHg)	0.54 kPa (4.06 mmHg, 0.160 inHg)	0.57 kPa (4.27 mmHg, 0.168 inHg)	0.60 kPa (4.48 mmHg, 0.176 inHg)
40 L (10.6 US gal, 8.8 Imp gal)	0.65 kPa (4.88 mmHg, 0.192 inHg)	0.65 kPa (4.90 mmHg, 0.193 inHg)	0.66 kPa (4.98 mmHg, 0.196 inHg)	0.71 kPa (5.32 mmHg, 0.209 inHg)	0.76 kPa (5.73 mmHg, 0.226 inHg)
50 L (13.2 US gal, 11.0 Imp gal)	0.79 kPa (5.90 mmHg, 0.232 inHg)	0.79 kPa (5.90 mmHg, 0.232 inHg)	0.79 kPa (5.90 mmHg, 0.232 inHg)	0.85 kPa (6.38 mmHg, 0.251 inHg)	0.88 kPa (6.60 mmHg, 0.260 inHg)

**Time Needed for Diagnosis:** 30 — 100 Seconds

**Malfunction Indicator Light Illumination:** Illuminates when malfunction occurs in 2 continuous drive cycles.

### • Leak diagnosis

DTC

P0456 Evaporative Emission Control System Leak Detected (very small leak)

### • Diagnostic method

- The diagnostic method consists of creating a sealed vacuum in the fuel tank and then determining the presence of leakage from the speed at which the tank internal pressure returns to atmospheric pressure.
- The diagnosis is divided into the following five phases.

#### **Mode A: (0 point correction)**

Wait until the tank pressure returns to 0 point (near 0 mmHg) when tank pressure is high. Then change to Mode B. If the tank pressure does not return to 0 point in the specified time, cancel the diagnosis.

#### **Mode B: (Negative pressure introduction)**

Introduce the negative pressure in the intake manifold to the tank.

Approx. 0 → -2.0 kPa (0 → -15 mmHg, 0 → -0.59 inHg)

When the pressure above (desired negative pressure) is reached, Mode C is entered.

In this case, if the tank pressure does not become the desired negative pressure, cancel the diagnosis.

#### **Mode C: (Holding negative pressure)**

Stop the introduction of negative pressure. (Wait until the tank pressure returns to the start level of P2 calculation.)

Change to Mode D when the tank pressure returns to the start level of P2 calculation, or when spending the specified time.

#### **Mode D: (Calculation of negative pressure variation)**

By monitoring the tank pressure at Mode D, calculate the pressure variation (P2) and measure the time (evp-dset) it takes the tank pressure to return to the detection completing pressure of P2. Then change to Mode E. When the tank pressure does not return to the detection completing pressure of P2 in the specified time, make advanced OK judgment or cancel the diagnosis according to P2 value.

# Diagnostic Trouble Code (DTC) Detecting Criteria

## GENERAL DESCRIPTION

### • Normality judgment

Judge OK when the following criteria are satisfied.

#### Judgment Value

Malfunction Criteria	Threshold Value
Advanced OK judgment 1 Mode D holding time Tank pressure	$\geq 30$ seconds $\leq -1.8$ kPa (-13.4 mmHg, -0.53 inHg)
Advanced OK judgment 2 Mode D holding time P2	$\geq 200$ seconds $\leq 0.9 - 1.3$ kPa (7 — 9.6 mmHg, 0.28 — 0.38 inHg)

### Mode E (Calculation of yielded evaporation amount)

Calculate the pressure variation (P1) at the time (evpdset), and make NG/OK judgment according to P1 value (ambiguous determination acceptable).

### • Abnormality Judgment

Judge NG when the following criteria are satisfied.

#### Judgment Value

Malfunction Criteria	Threshold Value
P1	< Value from Map 7 * Threshold value: Map (Fuel level vs evpdset)

### Map 7 Limit of malfunction criteria as Evap. diagnosis

Time (evpdset) vs Fuel level	0 seconds	30 seconds	80 seconds	100 seconds	150 seconds	200 seconds
10 L (2.6 US gal, 2.2 Imp gal)	0 kPa (0 mmHg, 0 inHg)	0.21 kPa (1.6 mmHg, 0.063 inHg)	0.29 kPa (2.2 mmHg, 0.087 inHg)	0.29 kPa (2.2 mmHg, 0.087 inHg)	0.29 kPa (2.2 mmHg, 0.087 inHg)	0.29 kPa (2.2 mmHg, 0.087 inHg)
30 L (7.9 US gal, 6.6 Imp gal)	0 kPa (0 mmHg, 0 inHg)	0.21 kPa (1.6 mmHg, 0.063 inHg)	0.29 kPa (2.2 mmHg, 0.087 inHg)	0.29 kPa (2.2 mmHg, 0.087 inHg)	0.29 kPa (2.2 mmHg, 0.087 inHg)	0 kPa (0 mmHg, 0 inHg)
50 L (13.2 US gal, 11.0 Imp gal)	0 kPa (0 mmHg, 0 inHg)	0.24 kPa (1.8 mmHg, 0.071 inHg)	0.29 kPa (2.2 mmHg, 0.087 inHg)	0.29 kPa (2.2 mmHg, 0.087 inHg)	0 kPa (0 mmHg, 0 inHg)	0 kPa (0 mmHg, 0 inHg)

### • Normality judgment

Judge OK when the following criteria are satisfied.

#### Judgment Value

Malfunction Criteria	Threshold Value
P1	> Value from Map 8 * Threshold value: Map (Fuel level vs evpdset)

# Diagnostic Trouble Code (DTC) Detecting Criteria

GENERAL DESCRIPTION

## Map 8 Limit of malfunction criteria as Evap. diagnosis

Time (evpdset) vs Fuel level	0 seconds	30 seconds	80 seconds	100 seconds	150 seconds	200 seconds
10 L (2.6 US gal, 2.2 Imp gal)	0.16 kPa (1.2 mmHg, 0.047 inHg)	0.37 kPa (2.8 mmHg, 0.110 inHg)	0.45 kPa (3.4 mmHg, 0.134 inHg)	0.45 kPa (3.4 mmHg, 0.134 inHg)	0.45 kPa (3.4 mmHg, 0.134 inHg)	0.45 kPa (3.4 mmHg, 0.134 inHg)
30 L (7.9 US gal, 6.6 Imp gal)	0.16 kPa (1.2 mmHg, 0.047 inHg)	0.37 kPa (2.8 mmHg, 0.110 inHg)	0.45 kPa (3.4 mmHg, 0.134 inHg)	0.45 kPa (3.4 mmHg, 0.134 inHg)	0.45 kPa (3.4 mmHg, 0.134 inHg)	0.45 kPa (3.4 mmHg, 0.134 inHg)
50 L (13.2 US gal, 11.0 Imp gal)	0.16 kPa (1.2 mmHg, 0.047 inHg)	0.40 kPa (3 mmHg, 0.118 inHg)	0.45 kPa (3.4 mmHg, 0.134 inHg)	0.45 kPa (3.4 mmHg, 0.134 inHg)	0.45 kPa (3.4 mmHg, 0.134 inHg)	0.45 kPa (3.4 mmHg, 0.134 inHg)

**Time Needed for Diagnosis:** 65 — 514 seconds

**Malfunction Indicator Light Illumination:** Illuminates when malfunction occurs in 2 continuous drive cycles.

### 6. DTC CLEAR CONDITION

- When the OK idling cycle was completed 40 times in a row
- When “Clear Memory” was performed

### 7. MALFUNCTION INDICATOR LIGHT CLEAR CONDITION

- When the OK driving cycle was completed 3 times in a row
- When “Clear Memory” was performed

### 8. FAIL SAFE

None

### 9. ECM OPERATION AT DTC SETTING

- Memorize the freeze frame data. (For test mode \$02)
- Memorize the diagnostic value and trouble standard value. (For test mode \$06)

# Diagnostic Trouble Code (DTC) Detecting Criteria

## GENERAL DESCRIPTION

### BG:DTC P0447 EVAPORATIVE EMISSION CONTROL SYSTEM VENT CONTROL CIRCUIT OPEN

#### 1. OUTLINE OF DIAGNOSIS

Detect the open or short circuit of drain valve.

Judge NG when the ECM output level is different from the actual terminal level.

#### 2. COMPONENT DESCRIPTION

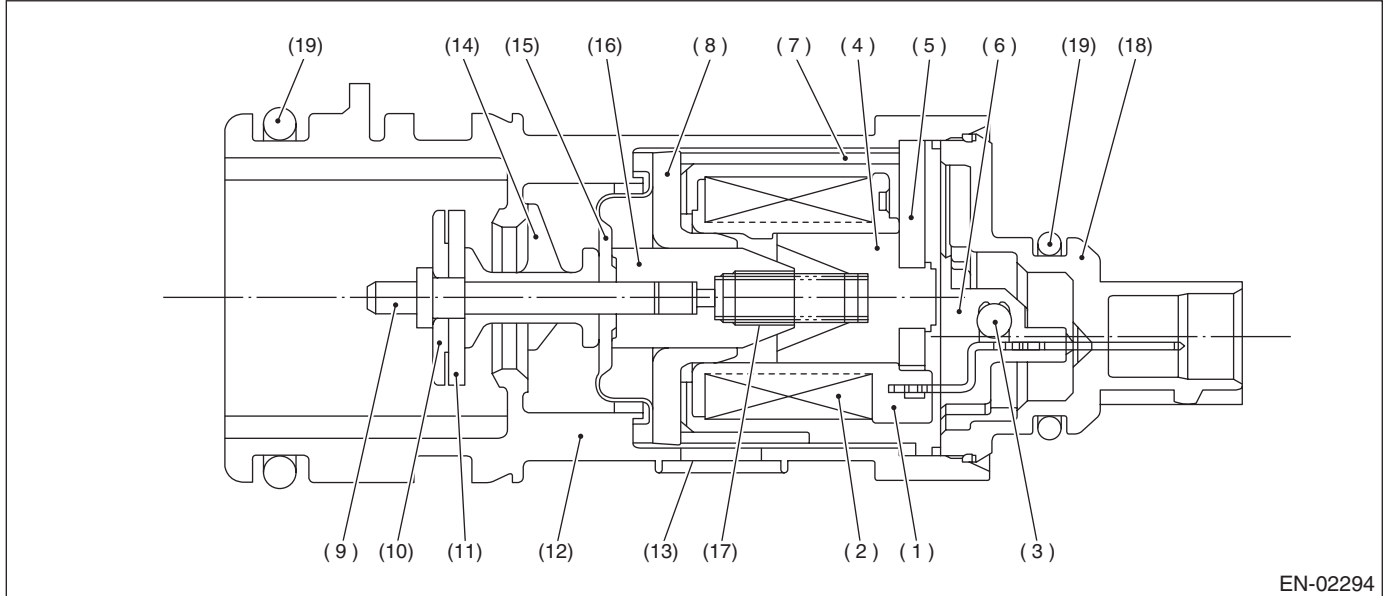

EN-02294

- |                 |                    |                  |
|-----------------|--------------------|------------------|
| (1) Bobbin      | (8) Magnetic plate | (15) Diaphragm   |
| (2) Coil        | (9) Shaft          | (16) Moving core |
| (3) Diode       | (10) Plate         | (17) Spring      |
| (4) Stator core | (11) Valve         | (18) Cover       |
| (5) End plate   | (12) Housing       | (19) O-ring      |
| (6) Body        | (13) Filter        |                  |
| (7) Yoke        | (14) Retainer      |                  |

#### 3. ENABLE CONDITION

Secondary Parameters	Enable Conditions
None	

#### 4. GENERAL DRIVING CYCLE

Always perform the diagnosis continuously.

# Diagnostic Trouble Code (DTC) Detecting Criteria

GENERAL DESCRIPTION

## 5. DIAGNOSTIC METHOD

### • Abnormality Judgment

Judge NG when the continuous time of completing the malfunction criteria below becomes more than 2.5 seconds.

### Judgment Value

Malfunction Criteria	Threshold Value
Ignition switch	ON
Battery voltage	$\geq 10.9$ V
After engine starting	1 second or more
Terminal output voltage when ECM sends OFF signal	Low

**Time Needed for Diagnosis:** 2.5 seconds

**Malfunction Indicator Light Illumination:** Illuminates as soon as the malfunction occurs.

### • Normality Judgment

Judge OK and clear the NG when the malfunction criteria below are completed.

### Judgment Value

Malfunction Criteria	Threshold Value
Ignition switch	ON
Battery voltage	$\geq 10.9$ V
After engine starting	1 second or more
Terminal output voltage when ECM sends OFF signal	High

## 6. DTC CLEAR CONDITION

- When the OK idling cycle was completed 40 times in a row
- When "Clear Memory" was performed

## 7. MALFUNCTION INDICATOR LIGHT CLEAR CONDITION

- When the OK driving cycle was completed 3 times in a row
- When "Clear Memory" was performed

## 8. FAIL SAFE

PCV control: Open the PCV solenoid.

## 9. ECM OPERATION AT DTC SETTING

Memorize the freeze frame data. (For test mode \$02)

# Diagnostic Trouble Code (DTC) Detecting Criteria

## GENERAL DESCRIPTION

### BH:DTC P0448 EVAPORATIVE EMISSION CONTROL SYSTEM VENT CONTROL CIRCUIT SHORTED

#### 1. OUTLINE OF DIAGNOSIS

Detect the open or short circuit of drain valve.

Judge NG when the ECM output level is different from the actual terminal level.

#### 2. COMPONENT DESCRIPTION

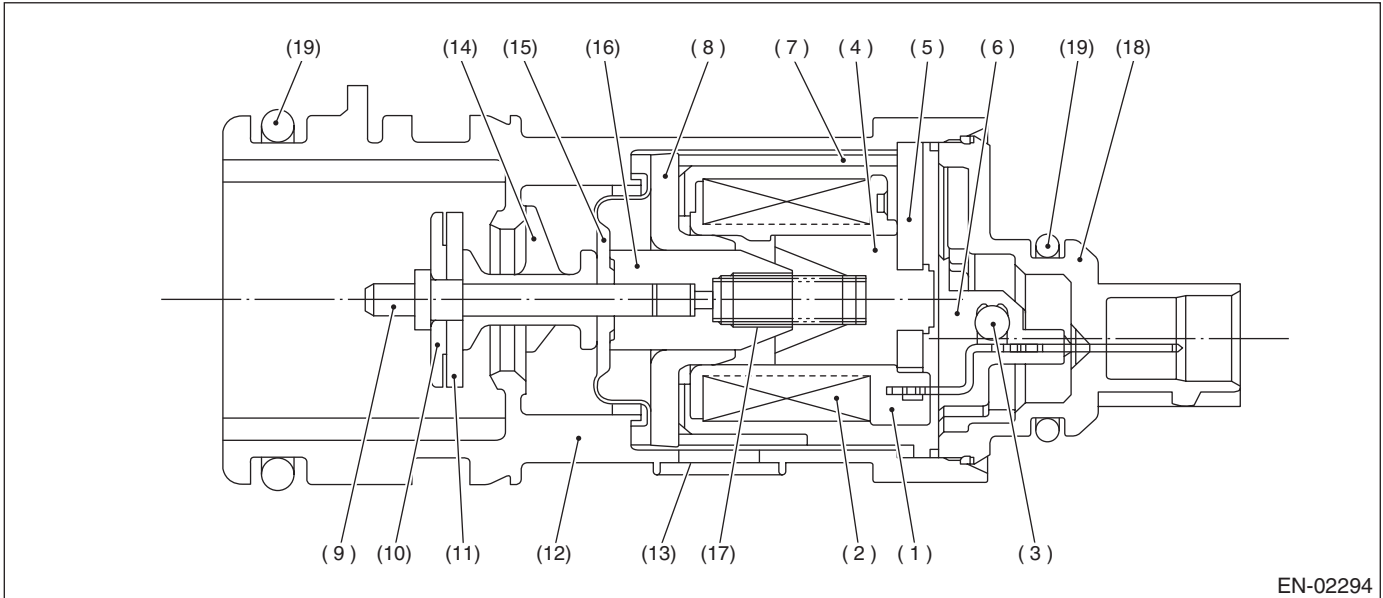

EN-02294

- |                 |                    |                  |
|-----------------|--------------------|------------------|
| (1) Bobbin      | (8) Magnetic plate | (15) Diaphragm   |
| (2) Coil        | (9) Shaft          | (16) Moving core |
| (3) Diode       | (10) Plate         | (17) Spring      |
| (4) Stator core | (11) Valve         | (18) Cover       |
| (5) End plate   | (12) Housing       | (19) O-ring      |
| (6) Body        | (13) Filter        |                  |
| (7) Yoke        | (14) Retainer      |                  |

#### 3. ENABLE CONDITION

Secondary Parameters	Enable Conditions
None	

#### 4. GENERAL DRIVING CYCLE

Always perform the diagnosis continuously.

# Diagnostic Trouble Code (DTC) Detecting Criteria

GENERAL DESCRIPTION

## 5. DIAGNOSTIC METHOD

### • Abnormality Judgment

Judge NG when the continuous time of completing the malfunction criteria below becomes more than 2.5 seconds.

### Judgment Value

Malfunction Criteria	Threshold Value
Ignition switch	ON
Battery voltage	$\geq 10.9$ V
After engine starting	1 second or more
Terminal output voltage when ECM sends ON signal	High

**Time Needed for Diagnosis:** 2.5 seconds

**Malfunction Indicator Light Illumination:** Illuminates as soon as the malfunction occurs.

### • Normality Judgment

Judge OK and clear the NG when the malfunction criteria below are completed.

### Judgment Value

Malfunction Criteria	Threshold Value
Ignition switch	ON
Battery voltage	$\geq 10.9$ V
After engine starting	1 second or more
Terminal output voltage when ECM sends ON signal	Low

## 6. DTC CLEAR CONDITION

- When the OK idling cycle was completed 40 times in a row
- When "Clear Memory" was performed

## 7. MALFUNCTION INDICATOR LIGHT CLEAR CONDITION

- When the OK driving cycle was completed 3 times in a row
- When "Clear Memory" was performed

## 8. FAIL SAFE

PCV control: Open the PCV solenoid.

## 9. ECM OPERATION AT DTC SETTING

Memorize the freeze frame data. (For test mode \$02)

# Diagnostic Trouble Code (DTC) Detecting Criteria

## GENERAL DESCRIPTION

### BI: DTC P0451 EVAPORATIVE EMISSION CONTROL SYSTEM PRESSURE SENSOR RANGE/PERFORMANCE

#### 1. OUTLINE OF DIAGNOSIS

Detect the tank pressure sensor output property abnormality.

Judge NG when there is no pressure variation, which should exist in the tank, considering the engine status.

#### 2. COMPONENT DESCRIPTION

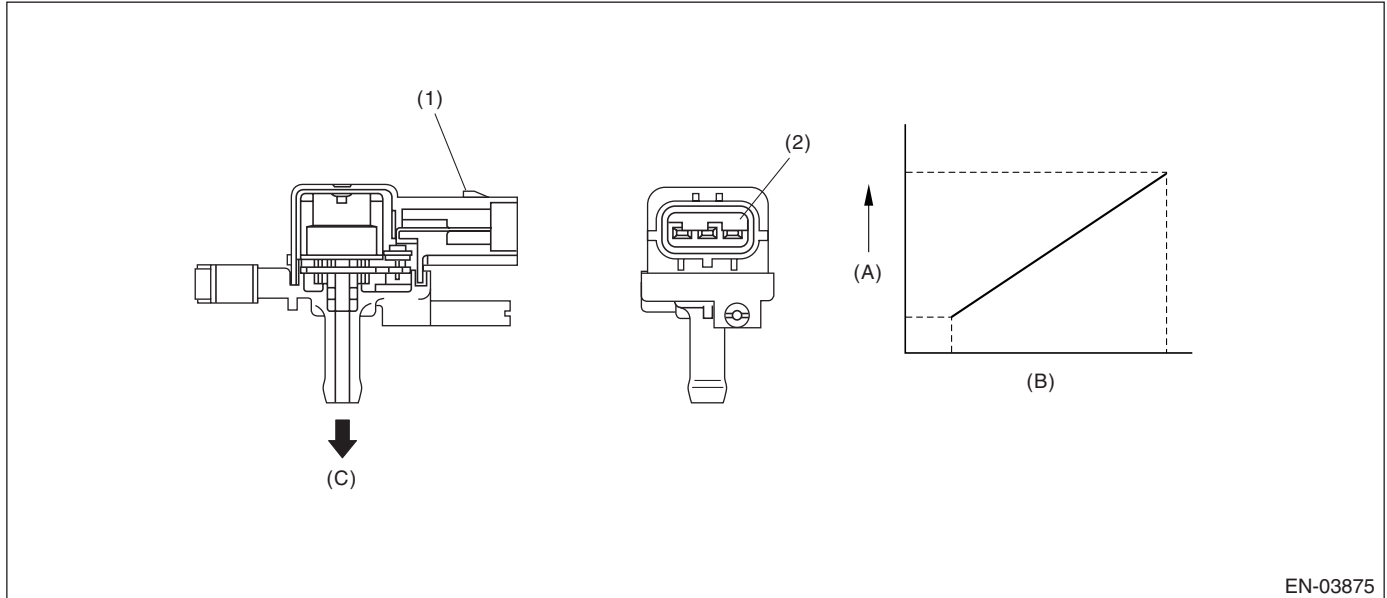

EN-03875

(1) Connector

(2) Terminal

(A) Output voltage

(B) Input voltage

(C) To fuel tank

#### 3. ENABLE CONDITION

Secondary Parameters	Enable Conditions
After starting the engine	60 second or more
Fuel level	$\geq 9.0 \ell$ (2.4 US gal, 2.0 Imp gal)
Fuel temperature	$< 35^{\circ}\text{C}$ ( $95^{\circ}\text{F}$ )
Battery voltage	$\geq 10.9 \text{ V}$
Atmospheric pressure	$> 75.1 \text{ kPa}$ (563 mmHg, 22.2 inHg)

#### 4. GENERAL DRIVING CYCLE

- Perform the diagnosis continuously in 60 seconds or more after starting the engine.
- Be sure to check the fuel level and fuel temperature.



# Diagnostic Trouble Code (DTC) Detecting Criteria

GENERAL DESCRIPTION

## 5. DIAGNOSTIC METHOD

### • Abnormality Judgment

Judge NG when the malfunction criteria below is completed.

#### Judgment Value

Malfunction Criteria	Threshold Value
Number of times when the difference between the Max. fuel level and the Min. fuel level every 60 seconds is 2 ℓ (0.53 US gal, 0.44Imp gal) or more (with enable condition completed)	≥ 16 times
Max. – Min. tank pressure (with enable condition completed)	< 0.05 kPa (0.375 mmHg, 0.015 inHg)
Max. – Min. fuel temperature (with enable condition completed)	≥ 7°C (12.6°F)

If the fuel level (Max. – Min.) in every 60 seconds is less than 2 ℓ, extend 60 seconds more and make judgment with the Max. and Min. fuel level in 120 seconds.

If the difference did not appear though the time extended, extend the time (180, 240, 300 seconds) and continue the judgment.

Diagnosis counter will count up when the difference of fuel level (Max. – Min.) is more than 2 ℓ.

**Time Needed for Diagnosis:** 1 minute × 16 times or more

**Malfunction Indicator Light Illumination:** Illuminates when malfunction occurs in two continuous drive cycles.

### • Normality Judgment

Judge OK when the malfunction criteria below is completed.

#### Judgment Value

Malfunction Criteria	Threshold Value
Max. – Min. tank pressure	≥ 0.05 kPa (0.375 mmHg, 0.015 inHg)

## 6. DTC CLEAR CONDITION

- When the OK idling cycle was completed 40 times in a row
- When “Clear Memory” was performed

## 7. MALFUNCTION INDICATOR LIGHT CLEAR CONDITION

- When the OK driving cycle was completed 3 times in a row
- When “Clear Memory” was performed

## 8. FAIL SAFE

Purge control solenoid valve control: Purge fixation mode is prohibited.

## 9. ECM OPERATION AT DTC SETTING

Memorize the freeze frame data. (For test mode \$02)

# Diagnostic Trouble Code (DTC) Detecting Criteria

## GENERAL DESCRIPTION

### BJ:DTC P0452 EVAPORATIVE EMISSION CONTROL SYSTEM PRESSURE SENSOR LOW INPUT

#### 1. OUTLINE OF DIAGNOSIS

Detect the open or short circuit of the fuel tank pressure sensor.  
Judge NG when out of the standard value.

#### 2. COMPONENT DESCRIPTION

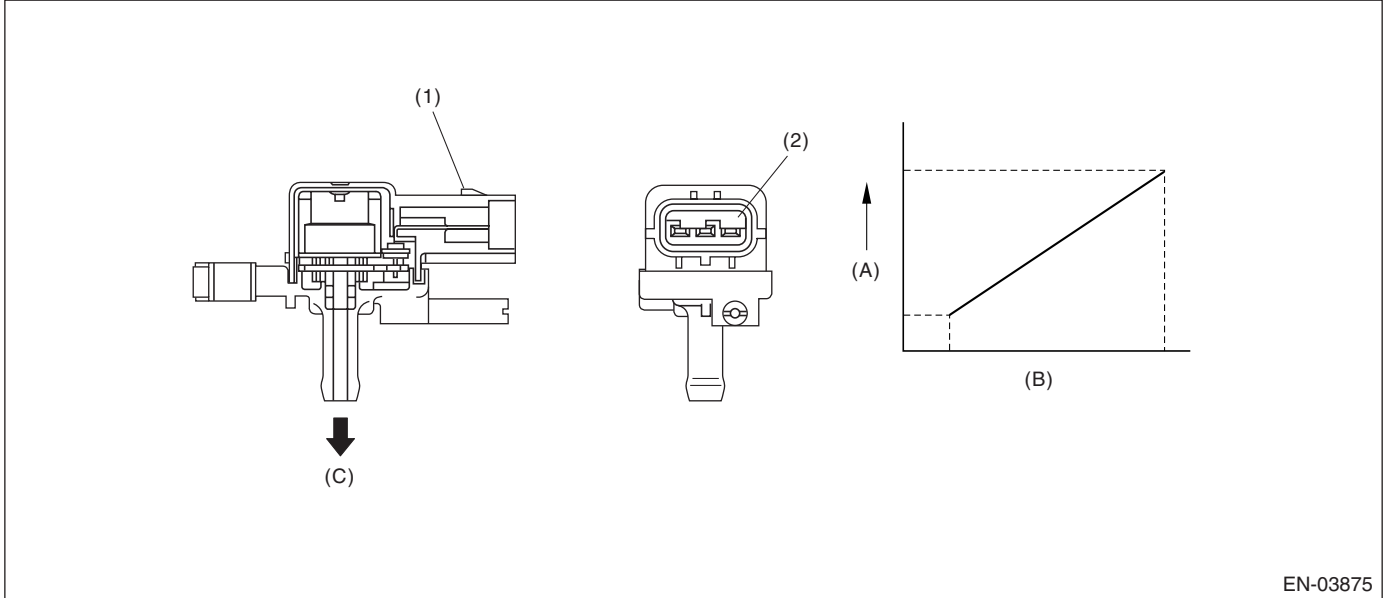

EN-03875

(1) Connector

(2) Terminal

(A) Output voltage

(B) Input voltage

(C) To fuel tank

#### 3. ENABLE CONDITION

Secondary Parameters	Enable Conditions
Battery voltage	$\geq 10.9$ V

#### 4. GENERAL DRIVING CYCLE

Always perform the diagnosis continuously.

#### 5. DIAGNOSTIC METHOD

##### • Abnormality Judgment

Judge NG when the continuous time of completing the malfunction criteria below becomes more than 15 seconds.

##### Judgment Value

Malfunction Criteria	Threshold Value
Fuel tank pressure	$\leq -7.48$ kPa ( $-56.15$ mmHg, $-2.21$ inHg)

**Time Needed for Diagnosis:** 15 seconds

**Malfunction Indicator Light Illumination:** Illuminates as soon as malfunction occurs.

# Diagnostic Trouble Code (DTC) Detecting Criteria

GENERAL DESCRIPTION

## • Normality Judgment

Judge OK when the malfunction criteria below is completed.

### Judgment Value

Malfunction Criteria	Threshold Value
Fuel tank pressure	> -7.48 kPa (-56.15 mmHg, -2.21 inHg)

## 6. DTC CLEAR CONDITION

- When the OK idling cycle was completed 40 times in a row
- When "Clear Memory" was performed

## 7. MALFUNCTION INDICATOR LIGHT CLEAR CONDITION

- When the OK driving cycle was completed 3 times in a row
- When "Clear Memory" was performed

## 8. FAIL SAFE

Purge control solenoid valve control: Purge fixation mode is prohibited.

## 9. ECM OPERATION AT DTC SETTING

Memorize the freeze frame data. (For test mode \$02)

# Diagnostic Trouble Code (DTC) Detecting Criteria

## GENERAL DESCRIPTION

### BK:DTC P0453 EVAPORATIVE EMISSION CONTROL SYSTEM PRESSURE SENSOR HIGH INPUT

#### 1. OUTLINE OF DIAGNOSIS

Detect the breaking/shortage of the fuel tank pressure sensor.  
Judge NG when out of the standard value.

#### 2. COMPONENT DESCRIPTION

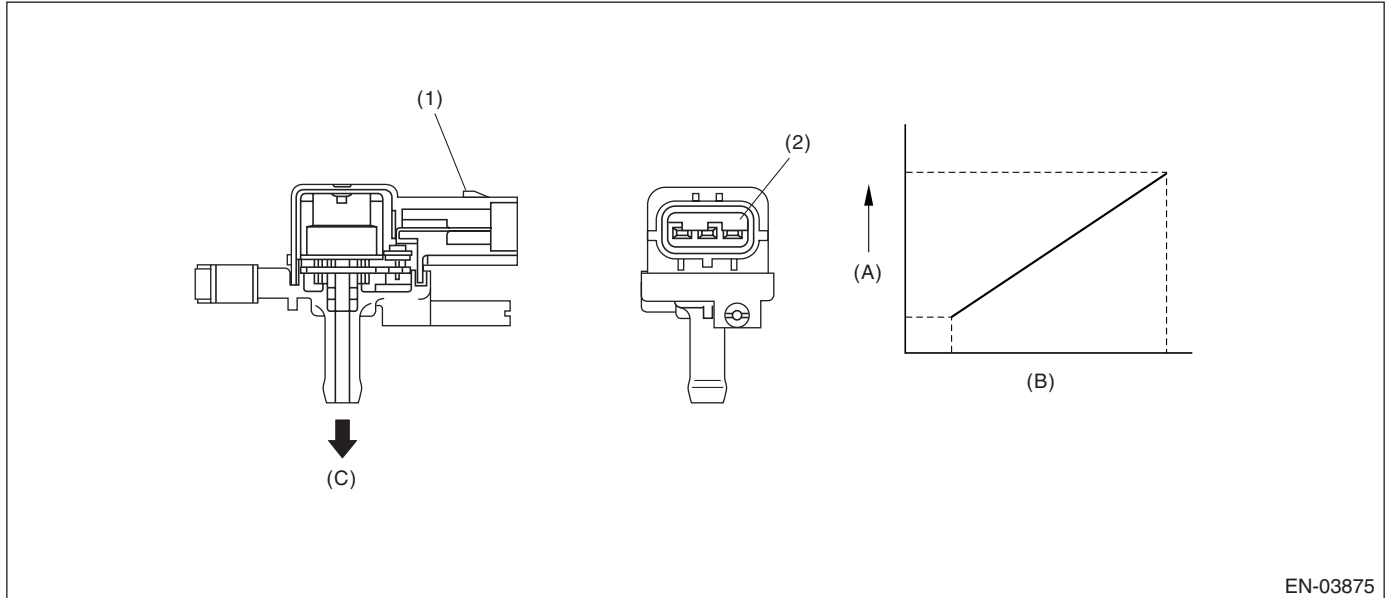

EN-03875

- (1) Connector  
(2) Terminal

- (A) Output voltage  
(B) Input voltage

- (C) To fuel tank

#### 3. ENABLE CONDITION

Secondary Parameters	Enable Conditions
Vehicle speed	$\geq 2$ km/h (1.24 MPH)
All conditions of EVAP canister purge	Complete
Evaporation gas density learning value	$\leq 0.08$
Main feedback compensation coefficient	$\geq 0.9$
Battery voltage	$\geq 10.9$ V

#### 4. GENERAL DRIVING CYCLE

Perform the diagnosis continuously when purging.

#### 5. DIAGNOSTIC METHOD

##### • Abnormality Judgment

Judge NG when the continuous time until completing the malfunction criteria below becomes more than 15 seconds.

##### Judgment Value

Malfunction Criteria	Threshold Value
Fuel tank pressure	$> 7.98$ kPa (59.86 mmHg, 2.36 inHg)
Fuel temperature	$< 35^{\circ}\text{C}$ (95°F)
Atmospheric pressure	$\geq 75.1$ kPa (563 mmHg, 22.2 inHg)

# Diagnostic Trouble Code (DTC) Detecting Criteria

GENERAL DESCRIPTION

**Time Needed for Diagnosis:** 15 seconds

**Malfunction Indicator Light Illumination:** Illuminates as soon as malfunction occurs.

• **Normality Judgment**

Judge OK when the malfunction criteria below is completed.

**Judgment Value**

Malfunction Criteria	Threshold Value
Fuel tank pressure	≤ 7.98 kPa (59.86 mmHg, 2.36 inHg)

## 6. DTC CLEAR CONDITION

- When the OK idling cycle was completed 40 times in a row
- When “Clear Memory” was performed

## 7. MALFUNCTION INDICATOR LIGHT CLEAR CONDITION

- When the OK driving cycle was completed 3 times in a row
- When “Clear Memory” was performed

## 8. FAIL SAFE

Purge control solenoid valve control: Purge fixation mode is prohibited.

## 9. ECM OPERATION AT DTC SETTING

Memorize the freeze frame data. (For test mode \$02)

## **BL:DTC P0456 EVAPORATIVE EMISSION CONTROL SYSTEM LEAK DETECTED (VERY SMALL LEAK)**

### 1. OUTLINE OF DIAGNOSIS

For detecting conditions, refer to DTC P0442 EVAPORATIVE EMISSION CONTROL SYSTEM LEAK DETECTED (SMALL LEAK). <Ref. to GD(H4SO)-101, DTC P0442 EVAPORATIVE EMISSION CONTROL SYSTEM LEAK DETECTED (SMALL LEAK), Diagnostic Trouble Code (DTC) Detecting Criteria.>

## **BM:DTC P0457 EVAPORATIVE EMISSION CONTROL SYSTEM LEAK DETECTED (FUEL CAP LOOSE/OFF)**

### 1. OUTLINE OF DIAGNOSIS

For detecting conditions, refer to DTC P0442 EVAPORATIVE EMISSION CONTROL SYSTEM LEAK DETECTED (SMALL LEAK). <Ref. to GD(H4SO)-101, DTC P0442 EVAPORATIVE EMISSION CONTROL SYSTEM LEAK DETECTED (SMALL LEAK), Diagnostic Trouble Code (DTC) Detecting Criteria.>

# Diagnostic Trouble Code (DTC) Detecting Criteria

## GENERAL DESCRIPTION

### BN:DTC P0458 EVAPORATIVE EMISSION CONTROL SYSTEM PURGE CONTROL VALVE CIRCUIT LOW

#### 1. OUTLINE OF DIAGNOSIS

Detect open or short circuit of purge control solenoid valve.  
Judge NG when ECM output level is different from actual terminal level.

#### 2. COMPONENT DESCRIPTION

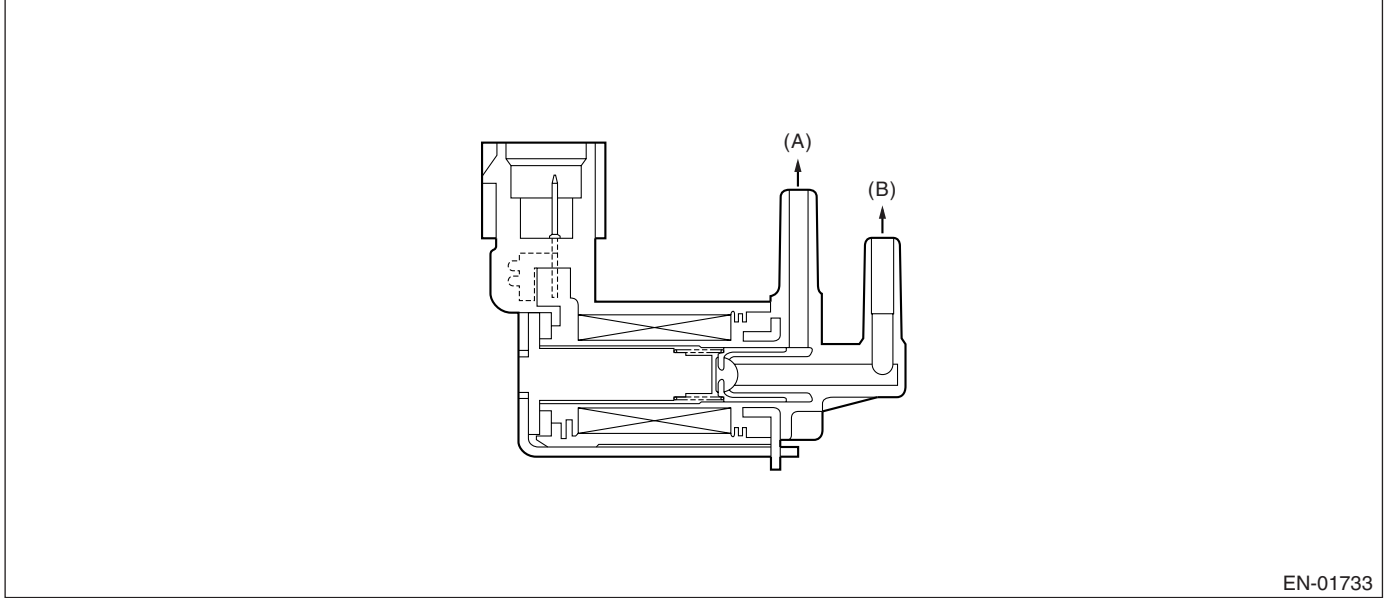

EN-01733

(A) To canister

(B) To intake manifold

#### 3. ENABLE CONDITION

Secondary Parameters	Enable Conditions
Ignition switch	ON
Battery voltage	$\geq 10.9$ V
After engine starting	1 second or more

#### 4. GENERAL DRIVING CYCLE

Always perform the diagnosis after starting the engine.

#### 5. DIAGNOSTIC METHOD

##### • Abnormality Judgment

Judge NG when the malfunction criteria below are completed.

##### Judgment Value

Malfunction Criteria	Threshold Value
Continuous time of completing criteria below.	$\geq 2.5$ seconds
Duty ratio of 'ON'	$< 75\%$
Terminal output voltage	Low

**Time Needed for Diagnosis:** 2.5 seconds

**Malfunction Indicator Light Illumination:** Illuminates as soon as malfunction occurs.

# Diagnostic Trouble Code (DTC) Detecting Criteria

GENERAL DESCRIPTION

## • Normality Judgment

Judge OK and clear NG when the malfunction criterion below is completed.

### Judgment Value

Malfunction Criteria	Threshold Value
Terminal output voltage	High

## 6. DTC CLEAR CONDITION

- When the OK idling cycle was completed 40 times in a row
- When "Clear Memory" was performed

## 7. MALFUNCTION INDICATOR LIGHT CLEAR CONDITION

- When the OK driving cycle was completed 3 times in a row
- When "Clear Memory" was performed

## 8. FAIL SAFE

None

## 9. ECM OPERATION AT DTC SETTING

Memorize the freeze frame data. (For test mode \$02)

## BO:DTC P0459 EVAPORATIVE EMISSION CONTROL SYSTEM PURGE CONTROL VALVE CIRCUIT HIGH

### 1. OUTLINE OF DIAGNOSIS

Detect open or short circuit of purge control solenoid valve.

Judge NG when ECM output level is different from actual terminal level.

### 2. COMPONENT DESCRIPTION

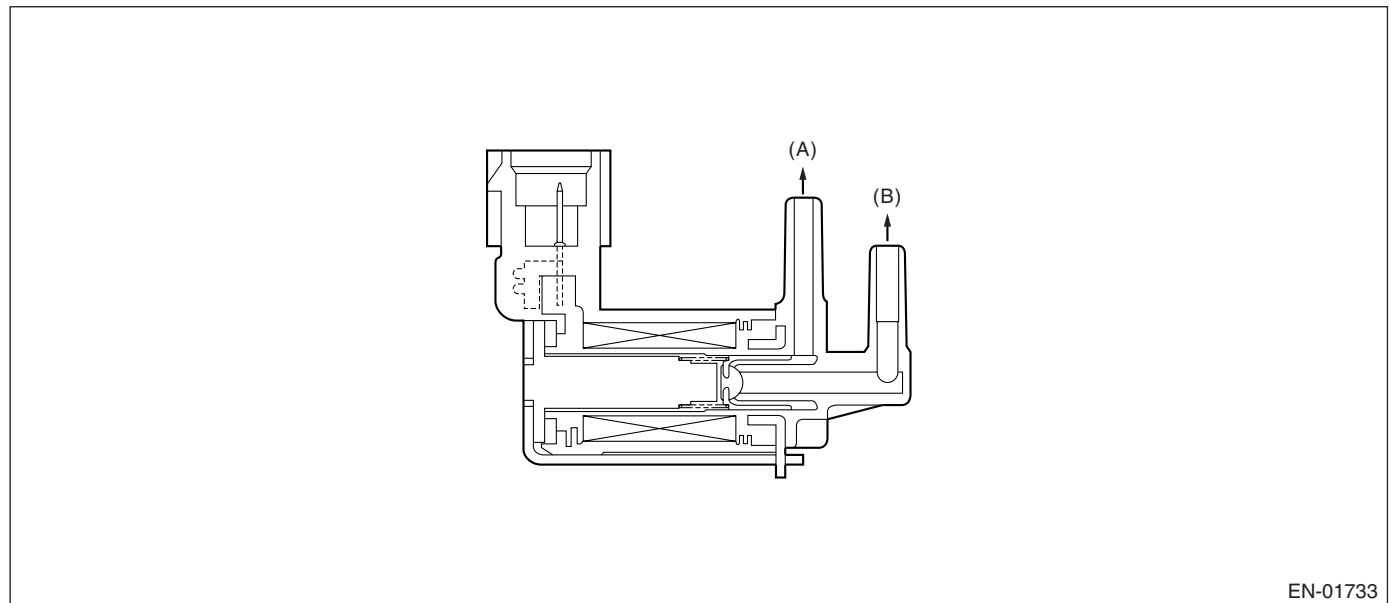

EN-01733

(A) To canister

(B) To intake manifold

### 3. ENABLE CONDITION

Secondary Parameters	Enable Conditions
Ignition switch	ON
Battery voltage	$\geq 10.9 \text{ V}$
After engine starting	1 second or more

# Diagnostic Trouble Code (DTC) Detecting Criteria

## GENERAL DESCRIPTION

---

### 4. GENERAL DRIVING CYCLE

Always perform the diagnosis after starting the engine.

### 5. DIAGNOSTIC METHOD

#### • Abnormality Judgment

Judge NG when the malfunction criteria below are completed.

#### Judgment Value

Malfunction Criteria	Threshold Value
Continuous time of completing criteria below.	≥ 2.5 seconds
Duty ratio of 'ON'	≥ 25%
Terminal output voltage	High

**Time Needed for Diagnosis:** 2.5 seconds

**Malfunction Indicator Light Illumination:** Illuminates when malfunction occurs in 2 continuous driving cycles.

#### • Normality Judgment

Judge OK and clear NG when the malfunction criterion below is completed.

#### Judgment Value

Malfunction Criteria	Threshold Value
Terminal output voltage	Low

### 6. DTC CLEAR CONDITION

- When the OK idling cycle was completed 40 times in a row
- When "Clear Memory" was performed

### 7. MALFUNCTION INDICATOR LIGHT CLEAR CONDITION

- When the OK driving cycle was completed 3 times in a row
- When "Clear Memory" was performed

### 8. FAIL SAFE

None

### 9. ECM OPERATION AT DTC SETTING

Memorize the freeze frame data. (For test mode \$02)



## BP:DTC P0461 FUEL LEVEL SENSOR CIRCUIT RANGE/PERFORMANCE

### 1. OUTLINE OF DIAGNOSIS

Detect the malfunction of fuel level sensor output property.

Judge NG when the fuel level does not vary whereas it seemed to vary be in a usual driving speed.

### 2. COMPONENT DESCRIPTION

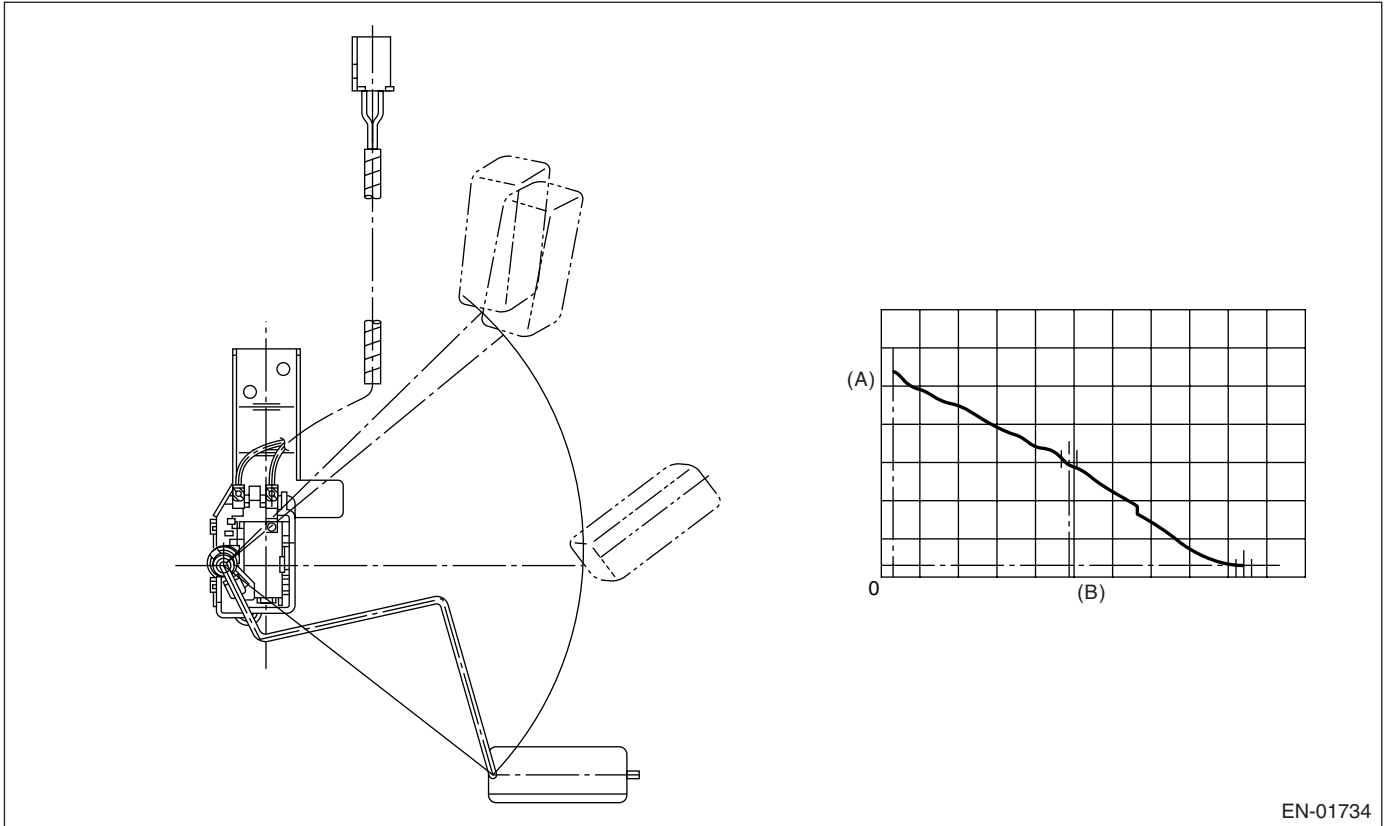

EN-01734

(A) Fuel level

(B) Resistance

### 3. ENABLE CONDITION

Secondary Parameters	Enable Conditions
None	

### 4. GENERAL DRIVING CYCLE

Always perform the diagnosis continuously.

### 5. DIAGNOSTIC METHOD

#### • Abnormality Judgment

Judge NG when the malfunction criteria below are completed.

#### Judgment Value

Malfunction Criteria	Threshold Value
Accumulated amount of intake air	> 331 kg (729.9 lb)
Max. – Min. fuel level output	< 2.6 ℓ (0.69 US gal, 0.57 Imp gal)
Battery voltage	≥ 10.9 V
After engine start	More than 5 seconds

# Diagnostic Trouble Code (DTC) Detecting Criteria

## GENERAL DESCRIPTION

---

**Time Needed for Diagnosis:** To be determined.

**Malfunction Indicator Light Illumination:** Illuminates when malfunction occurs in 2 continuous driving cycles.

• **Normality Judgment**

Judge OK and clear the NG when the malfunction criteria below are completed.

**Judgment Value**

Malfunction Criteria	Threshold Value
Accumulated amount of intake air	> 331 kg (729.9 lb)
Max.– Min. fuel level output	≥ 2.6 ℓ (0.69 US gal, 0.57 Imp gal)
Battery voltage	≥ 10.9 V
After engine start	More than 5 seconds

### 6. DTC CLEAR CONDITION

- When the OK idling cycle was completed 40 times in a row
- When “Clear Memory” was performed

### 7. MALFUNCTION INDICATOR LIGHT CLEAR CONDITION

- When the OK driving cycle was completed 3 times in a row
- When “Clear Memory” was performed

### 8. FAIL SAFE

None

### 9. ECM OPERATION AT DTC SETTING

Memorize the freeze frame data. (For test mode \$02)

# Diagnostic Trouble Code (DTC) Detecting Criteria

GENERAL DESCRIPTION

## BQ:DTC P0462 FUEL LEVEL SENSOR CIRCUIT LOW INPUT

### 1. OUTLINE OF DIAGNOSIS

Detect the open or short circuit of fuel level sensor. Judge NG when out of the standard value.

### 2. COMPONENT DESCRIPTION

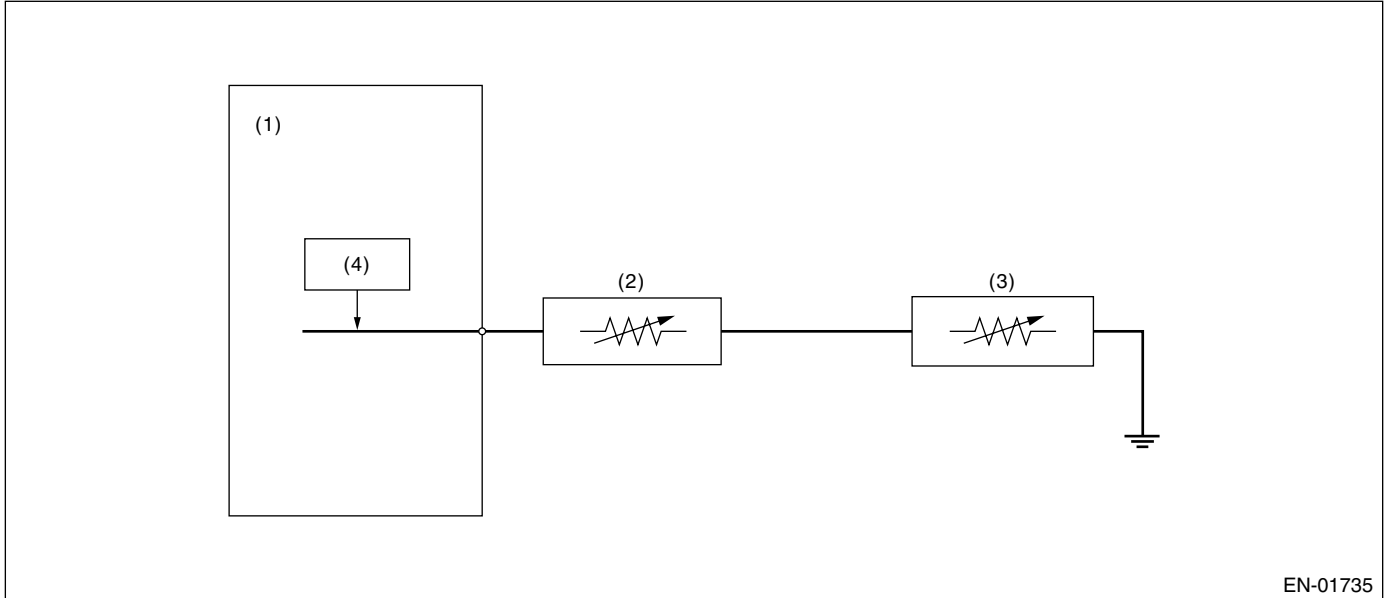

- (1) Engine control module (ECM)      (3) Fuel sub level sensor  
(2) Fuel level sensor                      (4) Detecting circuit

### 3. ENABLE CONDITION

Secondary Parameters	Enable Conditions
None	

### 4. GENERAL DRIVING CYCLE

Always perform the diagnosis continuously

### 5. DIAGNOSTIC METHOD

#### • Abnormality Judgment

Judge NG when the continuous time of completing the malfunction criteria below becomes more than 2.5 seconds.

#### Judgment Value

Malfunction Criteria	Threshold Value
Ignition switch	ON
Battery voltage	$\geq 10.9 \text{ V}$
After engine starting	3 seconds or more
Output voltage	$\leq 0.035 \text{ V}$

**Time Needed for Diagnosis:** 2.5 seconds

**Malfunction Indicator Light Illumination:** Illuminates when malfunction occurs in 2 continuous driving cycles.

# Diagnostic Trouble Code (DTC) Detecting Criteria

## GENERAL DESCRIPTION

---

### • Normality Judgment

Judge OK and clear the NG when the malfunction criteria below are completed.

### Judgment Value

Malfunction Criteria	Threshold Value
Ignition switch	ON
Battery voltage	$\geq 10.9$ V
After engine starting	3 seconds or more
Output voltage	$> 0.035$ V

### 6. DTC CLEAR CONDITION

- When the OK idling cycle was completed 40 times in a row
- When "Clear Memory" was performed

### 7. MALFUNCTION INDICATOR LIGHT CLEAR CONDITION

- When the OK driving cycle was completed 3 times in a row
- When "Clear Memory" was performed

### 8. FAIL SAFE

None

### 9. ECM OPERATION AT DTC SETTING

Memorize the freeze frame data. (For test mode \$02)

# Diagnostic Trouble Code (DTC) Detecting Criteria

GENERAL DESCRIPTION

## BR:DTC P0463 FUEL LEVEL SENSOR CIRCUIT HIGH INPUT

### 1. OUTLINE OF DIAGNOSIS

Detect the open or short circuit of fuel level sensor. Judge NG when out of the standard value.

### 2. COMPONENT DESCRIPTION

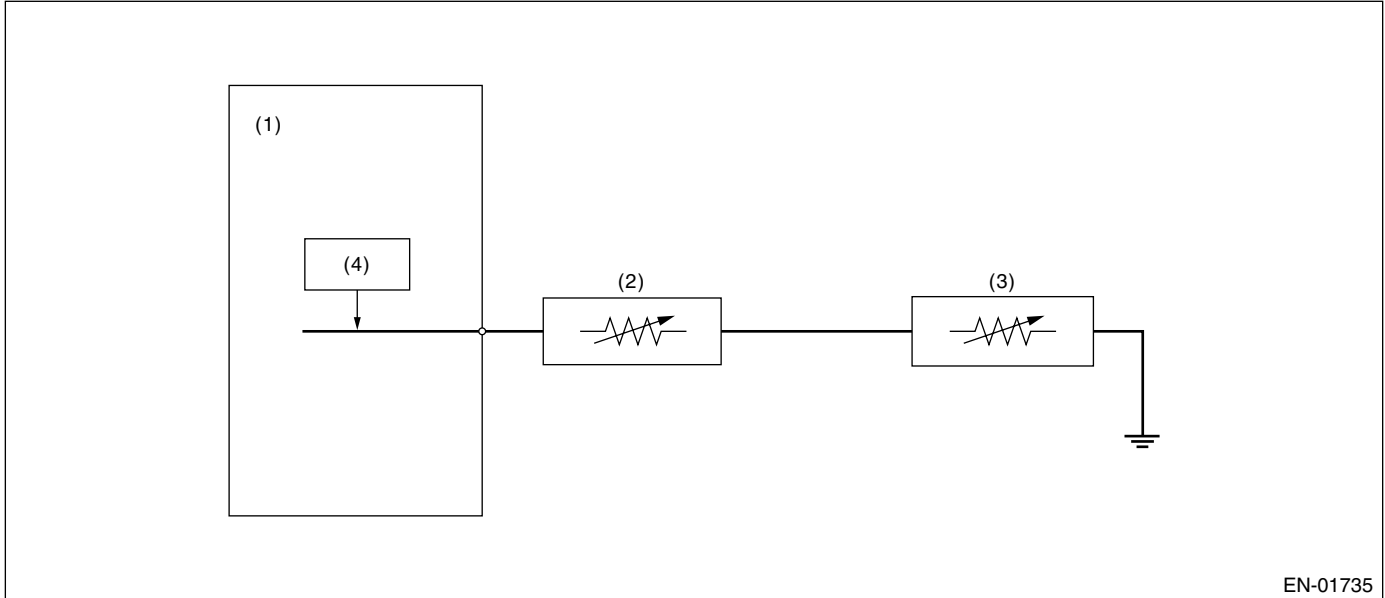

EN-01735

- (1) Engine control module (ECM)      (3) Fuel sub level sensor  
(2) Fuel level sensor                      (4) Detecting circuit

### 3. ENABLE CONDITION

Secondary Parameters	Enable Conditions
None	

### 4. GENERAL DRIVING CYCLE

Always perform the diagnosis continuously.

### 5. DIAGNOSTIC METHOD

#### • Abnormality Judgment

Judge NG when the continuous time of completing the malfunction criteria below becomes more than 2.5 seconds.

#### Judgment Value

Malfunction Criteria	Threshold Value
Ignition switch	ON
Battery voltage	$\geq 10.9$ V
After engine starting	3 seconds or more
Output voltage	$\geq 4.911$ V

**Time Needed for Diagnosis:** 2.5 seconds

**Malfunction Indicator Light Illumination:** Illuminates when malfunction occurs in 2 continuous driving cycles.

# Diagnostic Trouble Code (DTC) Detecting Criteria

## GENERAL DESCRIPTION

---

### • Normality Judgment

Judge OK and clear the NG when the malfunction criteria below are completed.

### Judgment Value

Malfunction Criteria	Threshold Value
Ignition switch	ON
Battery voltage	$\geq 10.9$ V
After engine starting	3 seconds or more
Output voltage	$< 4.911$ V

### 6. DTC CLEAR CONDITION

- When the OK idling cycle was completed 40 times in a row
- When "Clear Memory" was performed

### 7. MALFUNCTION INDICATOR LIGHT CLEAR CONDITION

- When the OK driving cycle was completed 3 times in a row
- When "Clear Memory" was performed

### 8. FAIL SAFE

None

### 9. ECM OPERATION AT DTC SETTING

Memorize the freeze frame data. (For test mode \$02)

# Diagnostic Trouble Code (DTC) Detecting Criteria

GENERAL DESCRIPTION

## BS:DTC P0464 FUEL LEVEL SENSOR CIRCUIT INTERMITTENT

### 1. OUTLINE OF DIAGNOSIS

Detect the malfunction of unstable output from fuel level sensor caused by noise.

Judge NG when the max. value and cumulative value of output voltage variation of fuel level sensor is larger than the threshold value.

### 2. ENABLE CONDITION

Secondary Parameters	Enable Conditions
Engine speed	≥ 500 rpm
After engine starting	1 second or more
Ignition switch	ON
Battery voltage	> 10.9 V
Idle switch	ON
Fuel level	9.0 ↔ 51 ℓ (2.38 ↔ 13.5 US gal, 2 ↔ 11.2 Imp gal)
Vehicle speed = 0 km/h (0 MPH)	10 seconds or more

### 3. GENERAL DRIVING CYCLE

- Perform the diagnosis continuously in idling condition.
- Pay attention to the fuel level.

# Diagnostic Trouble Code (DTC) Detecting Criteria

## GENERAL DESCRIPTION

### 4. DIAGNOSTIC METHOD

Calculate the Max. value (delflmax) and cumulative value (sumfl) of output voltage variation of fuel level sensor during 12.2 seconds. Judge it normal when both max. and cumulative values are not over the threshold value. Otherwise, when either of them is over the threshold value, count the diagnosis counter up. And judge NG if the counter indicated 4 counts.

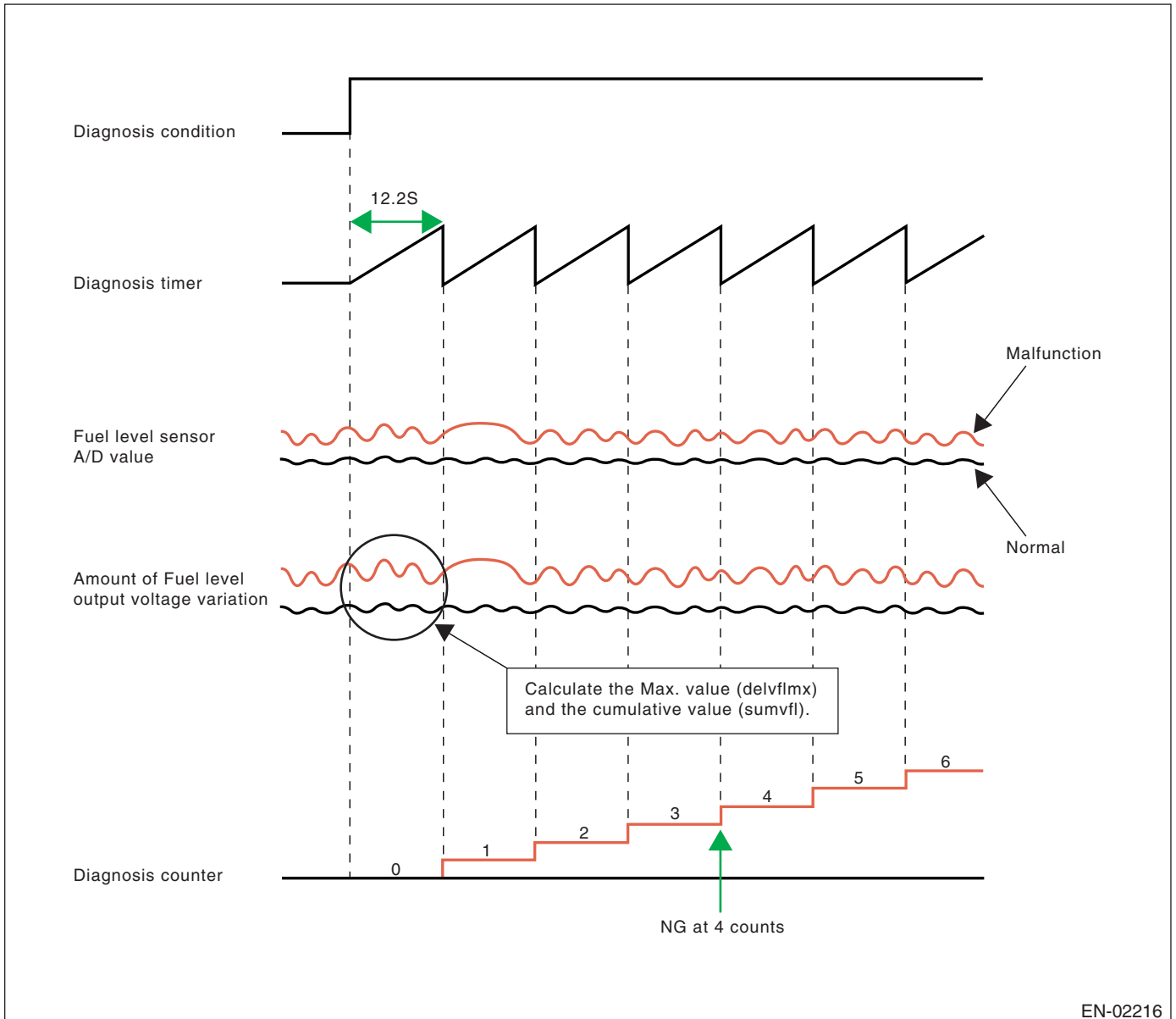

EN-02216



# Diagnostic Trouble Code (DTC) Detecting Criteria

GENERAL DESCRIPTION

## • Abnormality Judgment

Judge NG when the malfunction criteria below are completed.

### Judgment Value

Malfunction Criteria	Threshold Value
Integrated times of the condition reaching follows, DELFLMAX $\geq 0.2 \leftrightarrow 0.26$ V or SUMFL $\geq 16$ V where, DELFLMAX is Max. deviation of sensor output during 12.2 seconds. SUMFL is integrated value of sensor output deviation during 12.2 seconds.	$\geq 4$ times

Do not count the diagnosis counter up when the following conditions are completed during 12.2 seconds.

Max – Min of tank pressure during 12.2 seconds	$\geq 0.05$ kPa (0.375 mmHg, 0.015 inHg)
Max – Min of battery voltage during 12.2 seconds	$\geq 1.65$ V

**Time Needed for Diagnosis:** 12.2 seconds  $\times$  4 times

**Malfunction Indicator Light Illumination:** Illuminates when malfunction occurs in 2 continuous driving cycles.

## • Normality Judgment

Judge OK and clear the NG when the malfunction criteria below are completed.

### Judgment Value

Malfunction Criteria	Threshold Value
DELFLMAX SUMFL Where, DELFLMAX is Max. deviation of sensor output during 12.2 seconds. SUMFL is integrated value of sensor output deviation during 12.2 seconds.	$< 0.2 \leftrightarrow 0.26$ V $< 16$ V

## 5. DTC CLEAR CONDITION

- When the OK idling cycle was completed 40 times in a row
- When "Clear Memory" was performed

## 6. MALFUNCTION INDICATOR LIGHT CLEAR CONDITION

- When the OK driving cycle was completed 3 times in a row
- When "Clear Memory" was performed

## 7. FAIL SAFE

None

## 8. ECM OPERATION AT DTC SETTING

Memorize the freeze frame data. (For test mode \$02)

# Diagnostic Trouble Code (DTC) Detecting Criteria

## GENERAL DESCRIPTION

### BT:DTC P0483 COOLING FAN RATIONALITY CHECK

#### 1. OUTLINE OF DIAGNOSIS

Detect the function abnormality of the radiator fan.

Judge NG when the engine coolant temperature slowly decreases even when the radiator fan is rotating.

#### 2. ENABLE CONDITION

Diagnostic enable condition is completed if the radiator fan changes from OFF to ON when all of the conditions below are completed. When one of the conditions below is not completed, the diagnostic enable condition is not completed.

Secondary Parameters	Enable Conditions
Engine Speed	560 — 900 rpm
Idle switch	ON
Vehicle speed	< 2 km/h (1.2 MPH)
Battery voltage	≥ 10.9 V

#### 3. GENERAL DRIVING CYCLE

Perform the diagnosis continuously when the radiator fan changes from OFF to ON when idling.

#### 4. DIAGNOSTIC METHOD

##### • Abnormality Judgment

Judge NG when the continuous time of completing the malfunction criteria below becomes more than 5 minutes.

##### Judgment Value

Malfunction Criteria	Threshold Value
Engine coolant temperature	≥ 100°C (212°F)
Radiator fan signal changes	OFF to ON
Engine coolant temperature	Not reducing

**Time Needed for Diagnosis:** 5 minutes

**Malfunction Indicator Light Illumination:** Illuminates when malfunction occurs in 2 continuous driving cycles.

##### • Normality Judgment

Judge OK and clear NG when the malfunction criteria below are completed.

##### Judgment Value

Malfunction Criteria	Threshold Value
Radiator fan signal changes	OFF to ON
Engine coolant temperature	Reducing

#### 5. DTC CLEAR CONDITION

- When the OK idling cycle was completed 40 times in a row
- When "Clear Memory" was performed

#### 6. MALFUNCTION INDICATOR LIGHT CLEAR CONDITION

- When the OK driving cycle was completed 3 times in a row
- When "Clear Memory" was performed

#### 7. FAIL SAFE

None

#### 8. ECM OPERATION AT DTC SETTING

Memorize the freeze frame data. (For test mode \$02)

# Diagnostic Trouble Code (DTC) Detecting Criteria

GENERAL DESCRIPTION

## BU:DTC P0502 VEHICLE SPEED SENSOR CIRCUIT LOW INPUT

### 1. OUTLINE OF DIAGNOSIS

Detect the open or short circuit of vehicle speed sensor.

Judge NG when low vehicle speed (0 km/h (0 MPH)) remains whereas it seemed to be in a usual driving speed.

### 2. ENABLE CONDITION (USED WITH ABNORMAL JUDGEMENT)

Secondary Parameters	Enable Conditions
Engine speed	< 4,000 rpm
Fuel cut in decel.	Operating
Battery voltage	≥ 10.9 V

### 3. GENERAL DRIVING CYCLE

Perform the diagnosis continuously during fuel cut in deceleration.

### 4. DIAGNOSTIC METHOD

#### • Abnormality Judgment

Judge NG when the continuous time of completing the malfunction criteria below becomes more than 4 seconds.

#### Judgment Value

Malfunction Criteria	Threshold Value
Vehicle speed	< 1

**Time Needed for Diagnosis:** 4 seconds

**Malfunction Indicator Light Illumination:** Illuminates as soon as the malfunction occurs.

#### • Normality Judgment

Judge OK and clear the NG when all malfunction criteria below are completed.

#### Judgment Value

Malfunction Criteria	Threshold Value
Vehicle speed	≥ 1
Starter switch	OFF
Time after starter switch ON → OFF	≥ 3 seconds

### 5. DTC CLEAR CONDITION

- When the OK idling cycle was completed 40 times in a row
- When "Clear Memory" was performed

### 6. MALFUNCTION INDICATOR LIGHT CLEAR CONDITION

- When the OK driving cycle was completed 3 times in a row
- When "Clear Memory" was performed

### 7. FAIL SAFE

- Vehicle speed sensor signal process: Vehicle speed = 10 km/h (6 MPH)
- ISC control: Set the open loop compensation to specified value (1 g (0.04 oz)/s). Not allowed ISC feedback volume calculation.
- Radiator fan control: ON both main/sub.
- Tumble generator valve control: Open the tumble generator valve.

### 8. ECM OPERATION AT DTC SETTING

Memorize the freeze frame data. (For test mode \$02)

# Diagnostic Trouble Code (DTC) Detecting Criteria

## GENERAL DESCRIPTION

### BV:DTC P0503 VEHICLE SPEED SENSOR INTERMITTENT/ERRATIC/HIGH

#### 1. OUTLINE OF DIAGNOSIS

Detect the open or short circuit of vehicle speed sensor.

Judge NG when high vehicle speed (240 km/h (149.1 MPH) or more) remains whereas it seemed to be in a usual driving speed.

#### 2. ENABLE CONDITION (USED WITH ABNORMAL JUDGEMENT)

Secondary Parameters	Enable Conditions
Engine speed	< 4,000 rpm
Fuel cut in decel.	Operating
Battery voltage	≥ 10.9 V

#### 3. GENERAL DRIVING CYCLE

Perform the diagnosis continuously during fuel cut in deceleration.

#### 4. DIAGNOSTIC METHOD

##### • Abnormality Judgment

Judge NG when the cumulative time of completing the malfunction criteria below becomes more than 4 seconds.

##### Judgment Value

Malfunction Criteria	Threshold Value
Vehicle speed	≥ 240

**Time Needed for Diagnosis:** 4 seconds

**Malfunction Indicator Light Illumination:** Illuminates as soon as the malfunction occurs.

##### • Normality Judgment

Judge OK and clear the NG when all malfunction criteria below are completed.

##### Judgment Value

Malfunction Criteria	Threshold Value
Vehicle speed	< 240
Starter switch	OFF
Time after starter switch ON → OFF	≥ 3 seconds

#### 5. DTC CLEAR CONDITION

- When the OK idling cycle was completed 40 times in a row
- When "Clear Memory" was performed

#### 6. MALFUNCTION INDICATOR LIGHT CLEAR CONDITION

- When the OK driving cycle was completed 3 times in a row
- When "Clear Memory" was performed

#### 7. FAIL SAFE

- Vehicle speed sensor signal process: Vehicle speed = 10 km/h (6 MPH)
- ISC control: Set the open loop compensation to specified value (1 g (0.04 oz)/s). Not allowed ISC feedback volume calculation.
- Radiator fan control: ON both main/sub.
- Tumble generator valve control: Open the tumble generator valve.

#### 8. ECM OPERATION AT DTC SETTING

Memorize the freeze frame data. (For test mode \$02)

# Diagnostic Trouble Code (DTC) Detecting Criteria

GENERAL DESCRIPTION

## BW:DTC P0506 IDLE CONTROL SYSTEM RPM LOWER THAN EXPECTED

### 1. OUTLINE OF DIAGNOSIS

Detect the malfunction that actual engine speed is not close to target engine speed during idling.  
Judge NG when actual engine speed is not close to target engine speed during idling.

### 2. ENABLE CONDITION

Secondary Parameters	Enable Conditions
Engine coolant temperature	≥ 75°C (167°F)
Battery voltage	≥ 10.9 V
Atmospheric pressure	> 75.1 kPa (563 mmHg, 22.2 inHg)
Fuel level	≥ 9 ℓ (2.38 US gal, 1.98 Imp gal)
After engine starting	≥ 10.5 seconds
Feedback in ISC	In operation
Measured lambda	0.81 ←→ 1.1
After air condition switching ON-OFF, OFF-ON	> 5.1 seconds
After in-manifold pressure change more than 4 kPa (30 mmHg, 1.2 inHg)	> 5.1 seconds
After neutral switch ON-OFF event	> 5.1 seconds
Vehicle speed	0 km/h (0 MPH)

### 3. GENERAL DRIVING CYCLE

Always perform diagnosis during idling after engine warmed.

### 4. DIAGNOSTIC METHOD

#### • Abnormality Judgment

Judge NG when the cumulative time of completing the malfunction criterion below becomes more than the time needed for diagnosis (10 seconds × 3 times).

#### Judgment Value

Malfunction Criteria	Threshold Value
Actual – target engine speed	< –100 rpm
Feedback correction for idle air control solenoid valve	Max.

**Time Needed for Diagnosis:** 10 seconds × 3 times

**Malfunction Indicator Light Illumination:** Illuminates when malfunction occurs in 2 continuous driving cycles.

#### • Normality Judgment

Judge OK and clear NG when the continuous time of completing the malfunction criterion below becomes more than the time needed for diagnosis (10 seconds).

#### Judgment Value

Malfunction Criteria	Threshold Value
Actual – target engine speed	≥ –100 rpm

### 5. DTC CLEAR CONDITION

- When the OK idling cycle was completed 40 times in a row
- When “Clear Memory” was performed

### 6. MALFUNCTION INDICATOR LIGHT CLEAR CONDITION

- When the OK driving cycle was completed 3 times in a row
- When “Clear Memory” was performed

# Diagnostic Trouble Code (DTC) Detecting Criteria

## GENERAL DESCRIPTION

### 7. FAIL SAFE

None

### 8. ECM OPERATION AT DTC SETTING

Memorize the freeze frame data. (For test mode \$02)

## **BX:DTC P0507 IDLE CONTROL SYSTEM RPM HIGHER THAN EXPECTED**

### 1. OUTLINE OF DIAGNOSIS

Detect the malfunction that actual engine speed is not close to target engine speed during idling.  
Judge NG when actual engine speed is not close to target engine speed during idling.

### 2. ENABLE CONDITION

Secondary Parameters	Enable Conditions
Engine coolant temperature	≥ 75°C (167°F)
Battery voltage	≥ 10.9 V
Atmospheric pressure	> 75.1 kPa (563 mmHg, 22.2 inHg)
Fuel level	≥ 9 ℓ (2.38 US gal, 1.98 Imp gal)
After engine starting	≥ 10.5 seconds
Feedback in ISC	In operation
Lambda	0.81 ←→ 1.1
After air condition switching ON-OFF, OFF-ON	> 5.1 seconds
After in-manifold pressure change more than 4 kPa (30 mmHg, 1.2 inHg)	> 5.1 seconds
After neutral switch ON-OFF event	> 5.1 seconds
Vehicle speed	0 km/h (0 MPH)

### 3. GENERAL DRIVING CYCLE

Always perform diagnosis during idling after engine warmed.

### 4. DIAGNOSTIC METHOD

#### • Abnormality Judgment

Judge NG when the continuous time of completing the malfunction criterion below becomes more than the time needed for diagnosis (10 seconds × 3 times).

#### Judgment Value

Malfunction Criteria	Threshold Value
Actual – target eng. speed	≥ 200 rpm
Feedback correction for idle air control solenoid valve	Min.

**Time Needed for Diagnosis:** 10 seconds × 3 times

**Malfunction Indicator Light Illumination:** Illuminates when malfunction occurs in 2 continuous driving cycles.

#### • Normality Judgment

Judge OK and clear NG when the continuous time of completing the malfunction criterion below becomes more than the time needed for diagnosis (10 seconds).

#### Judgment Value

Malfunction Criteria	Threshold Value
Actual – target eng. speed	< 200 rpm

# Diagnostic Trouble Code (DTC) Detecting Criteria

GENERAL DESCRIPTION

## 5. DTC CLEAR CONDITION

- When the OK idling cycle was completed 40 times in a row
- When "Clear Memory" was performed

## 6. MALFUNCTION INDICATOR LIGHT CLEAR CONDITION

- When the OK driving cycle was completed 3 times in a row
- When "Clear Memory" was performed

## 7. FAIL SAFE

None

## 8. ECM OPERATION AT DTC SETTING

Memorize the freeze frame data. (For test mode \$02)

## BY:DTC P0512 STARTER REQUEST CIRCUIT

### 1. OUTLINE OF DIAGNOSIS

Detect the open or short circuit of starter SW.  
Judge ON NG when the starter SW signal remains on.

### 2. ENABLE CONDITION

Secondary Parameters	Enable Conditions
None	

### 3. GENERAL DRIVING CYCLE

Always perform the diagnosis continuously.

### 4. DIAGNOSTIC METHOD

#### • Abnormality Judgment

Judge NG when the continuous time of completing the malfunction criteria below becomes more than 3 minutes.

#### Judgment Value

Malfunction Criteria	Threshold Value
Engine speed	> 500 rpm
Starter OFF signal	Not detect
Battery voltage	> 8 V

**Time Needed for Diagnosis:** 180 seconds

**Malfunction Indicator Light Illumination:** Illuminates when malfunction occurs in 2 continuous driving cycles.

#### • Normality Judgment

Judge ON OK and clear the NG when the malfunction criteria below are completed.

#### Judgment Value

Malfunction Criteria	Threshold Value
Starter OFF signal	Detect
Battery voltage	> 8 V

## 5. DTC CLEAR CONDITION

- When the OK idling cycle was completed 40 times in a row
- When "Clear Memory" was performed

## 6. MALFUNCTION INDICATOR LIGHT CLEAR CONDITION

- When the OK driving cycle was completed 3 times in a row
- When "Clear Memory" was performed

# Diagnostic Trouble Code (DTC) Detecting Criteria

## GENERAL DESCRIPTION

---

### 7. FAIL SAFE

None

### 8. ECM OPERATION AT DTC SETTING

Memorize the freeze frame data. (For test mode \$02)

## **BZ:DTC P0513 INCORRECT IMMOBILIZER KEY**

### 1. OUTLINE OF DIAGNOSIS

DTC	ITEM	OUTLINE OF DIAGNOSIS
P0513	Incorrect Immobilizer Key	Incorrect immobilizer key (Use of key not registered in body integrated module)
P1570	Antenna	Improper antenna
P1571	Reference Code Incompatibility	Unmatched reference code between body integrated module and ECM
P1572	IMM Circuit Failure (Except Antenna Circuit)	Communication malfunction between body integrated module and ECM
P1574	Key Communication Failure	Malfunction of body integrated module that check the key (transponder) ID or Malfunction of transponder.
P1576	EGI Control Module EEPROM	Abnormality of ECM
P1577	IMM Control Module EEPROM	Malfunction of body integrated module.

### 2. ENABLE CONDITION

When the engine started.

### 3. GENERAL DRIVING CYCLE

Perform the diagnosis only when engine started.

### 4. DIAGNOSTIC METHOD

Judge NG when conditions of the above outline of diagnosis are completed.



# Diagnostic Trouble Code (DTC) Detecting Criteria

GENERAL DESCRIPTION

## CA:DTC P0519 IDLE CONTROL SYSTEM MALFUNCTION (FAIL-SAFE)

### 1. OUTLINE OF DIAGNOSIS

Detect the malfunction that engine speed increases more than that in normal condition during idling.

### 2. ENABLE CONDITION

Secondary Parameters	Enable Conditions
Battery voltage	$\geq 10.9$ V
Feedback in ISC	In operation
Vehicle speed	$< 4$ km/h (2.49 MPH)
After engine starting	1 seconds or more

### 3. GENERAL DRIVING CYCLE

Always perform diagnosis at less than 4 km/h (2.49 MPH) of vehicle speed.

### 4. DIAGNOSTIC METHOD

Judge NG when the continuous time of completing the malfunction criteria below becomes more than 2 seconds.

#### Judgment Value

Malfunction Criteria	Threshold Value
Engine speed – target eng. speed	$> 2,000$ rpm
Feedback value for ISC	$\leq 0$
Engine speed change every 180 degree engine rev.	$\geq -5$ rpm

**Time Needed for Diagnosis:** 2 seconds

**Malfunction Indicator Light Illumination:** Illuminates as soon as malfunction occurs.

#### • Normality Judgment

Judge OK and clear NG when the continuous time of completing the malfunction criteria below becomes more than 5 seconds.

#### Judgment Value

Malfunction Criteria	Threshold Value
Engine speed – target eng. speed	$< 200$ rpm

### 5. DTC CLEAR CONDITION

- When the OK idling cycle was completed 40 times in a row
- When “Clear Memory” was performed

### 6. MALFUNCTION INDICATOR LIGHT CLEAR CONDITION

- When the OK driving cycle was completed 3 times in a row
- When “Clear Memory” was performed

### 7. FAIL SAFE

Fuel shut-off: Shut-off fuel for only #1 and #2 cylinder, or for all cylinder in accordance with vehicle speed, engine speed, throttle position

### 8. ECM OPERATION AT DTC SETTING

Memorize the freeze frame data. (For test mode \$02)

# Diagnostic Trouble Code (DTC) Detecting Criteria

## GENERAL DESCRIPTION

---

### CB:DTC P0600 SERIAL COMMUNICATION LINK

#### 1. OUTLINE OF DIAGNOSIS

Detect the malfunction of CAN communication.

It judges as NG when CAN communication becomes impossible, the CAN communication with AT becomes impossible, and the data from AT is not normal.

#### 2. COMPONENT DESCRIPTION

CAN connects between ECM and TCM with high speed.

*(Common Specification)*

*CAN PROTOCOL 2.0B (active)*

*Frame format: 11 bit ID Frame (Standard frame)*

*(High Speed CAN)*

*ISO 11898 compliance*

*Communication Speed: 500 kbps*

#### 3. ENABLE CONDITION

Secondary Parameters	Enable Conditions
Battery Voltages	≥ 10.9 V
Starter switch	OFF
Engine	Run

#### 4. GENERAL DRIVING CYCLE

Perform the diagnosis continuously after starting the engine.

#### 5. DIAGNOSTIC METHOD

##### • JUDGMENT OF MALFUNCTION

Judge NG when any of the malfunction criteria below are completed. Judge OK and clear the NG when the continuous time of not completing the malfunction criteria below becomes more than 1 second.

##### Judgement Value

Malfunction Criteria	Threshold Value
Buss off flag or warning flag	Set
ID cannot be received from TCM	= 500 milliseconds

**Time needed for Diagnosis:** 1 time

**Malfunction Indicator Light Illumination:** Illuminates simultaneously when malfunction is detected.

#### 6. DTC CLEAR CONDITION

When the OK driving cycle was completed 40 consecutive times.

When "Clear Memory" was performed.

#### 7. MALFUNCTION INDICATOR LIGHT CLEAR CONDITION

- When the OK driving cycle was completed 3 consecutive times.
- When "Clear Memory" was performed.

#### 8. FAIL-SAFE

None

#### 9. ECM OPERATION AT DTC SETTING

Store the freeze frame data. (For test mode \$02)

# Diagnostic Trouble Code (DTC) Detecting Criteria

GENERAL DESCRIPTION

## CC:DTC P0604 INTERNAL CONTROL MODULE RANDOM ACCESS MEMORY (RAM) ERROR

### 1. OUTLINE OF DIAGNOSIS

Detect the function abnormality of the micro-computer (RAM).

Judge NG when either the main CPU normal RAM or sub CPU normal RAM is abnormal. Judge OK when both of them are normal.

At initial routine, write the data to all area of RAM. Judge OK when same data can be read out, and judge NG when same data cannot be read out.

### 2. ENABLE CONDITION

Secondary Parameters	Enable Conditions
None	

Perform the diagnosis in the initial routine.

### 3. GENERAL DRIVING CYCLE

Perform the diagnosis immediately after IG key SW is turned ON.

### 4. DIAGNOSTIC METHOD

#### • Abnormality Judgment

Judge NG when the malfunction criteria below are completed.

#### Judgment Value

Malfunction Criteria	Threshold Value
Main CPU normal RAM abnormality Write 5AA5A55A, and read out. (All area of RAM) Or write A55A5AA5, and read out. (All area of RAM)	Cannot be read out 5AA5A55A. Cannot be read out A55A5AA5.
Sub CPU normal RAM abnormality. Write 5AA5, and read out. (All area of RAM) Or write A55A, and read out. (All area of RAM)	Cannot be read out 5AA5. Cannot be read out A55A.

**Time Needed for Diagnosis:** To be determined.

**Malfunction Indicator Light Illumination:** Illuminates as soon as malfunction occurs.

#### • Normality Judgment

Judge NG when the malfunction criteria below are completed.

#### Judgment Value

Malfunction Criteria	Threshold Value
Main CPU normal RAM abnormality Write 5AA5A55A, and read out. (All area of RAM) Or write A55A5AA5, and read out. (All area of RAM)	Can be read out 5AA5A55A. Can be read out A55A5AA5.
Sub CPU normal RAM abnormality. Write 5AA5, and read out. (All area of RAM) Or write A55A, and read out. (All area of RAM)	Can be read out 5AA5. Can be read out A55A.

### 5. DTC CLEAR CONDITION

- When the OK idling cycle was completed 40 times in a row
- When "Clear Memory" was performed

# Diagnostic Trouble Code (DTC) Detecting Criteria

## GENERAL DESCRIPTION

---

### 6. MALFUNCTION INDICATOR LIGHT CLEAR CONDITION

- When the OK driving cycle was completed 3 times in a row
- When "Clear Memory" was performed

### 7. FAIL SAFE

None

### 8. ECM OPERATION AT DTC SETTING

Memorize the freeze frame data. (For test mode \$02)

## CD:DTC P0605 INTERNAL CONTROL MODULE READ ONLY MEMORY (ROM) ERROR

### 1. OUTLINE OF DIAGNOSIS

Judge NG when SUM value of ROM is out of the standard value.

### 2. ENABLE CONDITION

Secondary Parameters	Enable Conditions
Ignition switch	ON

### 3. GENERAL DRIVING CYCLE

Always perform the diagnosis continuously.

### 4. DIAGNOSTIC METHOD

#### • Abnormality Judgment

Judge NG when the continuous time of completing the malfunction criteria below becomes more than 0.5 seconds.

#### Judgment Value

Malfunction Criteria	Threshold Value
SUM value of ROM	Standard value

**Time Needed for Diagnosis:** To be determined

**Malfunction Indicator Light Illumination:** Illuminates as soon as malfunction occurs.

### 5. DTC CLEAR CONDITION

- When the OK idling cycle was completed 40 times in a row
- When "Clear Memory" was performed (Only at engine stop)

### 6. MALFUNCTION INDICATOR LIGHT CLEAR CONDITION

- When the OK driving cycle was completed 3 times in a row
- When "Clear Memory" was performed

### 7. FAIL SAFE

Stop the current to electronic throttle control motor. (Fix the throttle opening angle to 6°.)

### 8. ECM OPERATION AT DTC SETTING

Memorize the freeze frame data. (For test mode \$02)

## CE:DTC P0607 CONTROL MODULE PERFORMANCE

### 1. OUTLINE OF DIAGNOSIS

Judge NG when either the following is completed.

- When the read value of throttle position sensor 1 signal is mismatched between main CPU and sub CPU.
- When the read value of accelerator pedal position sensor 1 signal is mismatched between main CPU and sub CPU.
- When the sub CPU operates abnormally.
- When the communication between main CPU and sub CPU is abnormal.
- When the input amplifier circuit of throttle position sensor 1 is abnormal.
- When the cruise control cannot be canceled correctly.
- When the signal of brake SW1 and 2 is mismatched.
- When the directed angle from main CPU is abnormal.

### 2. COMPONENT DESCRIPTION

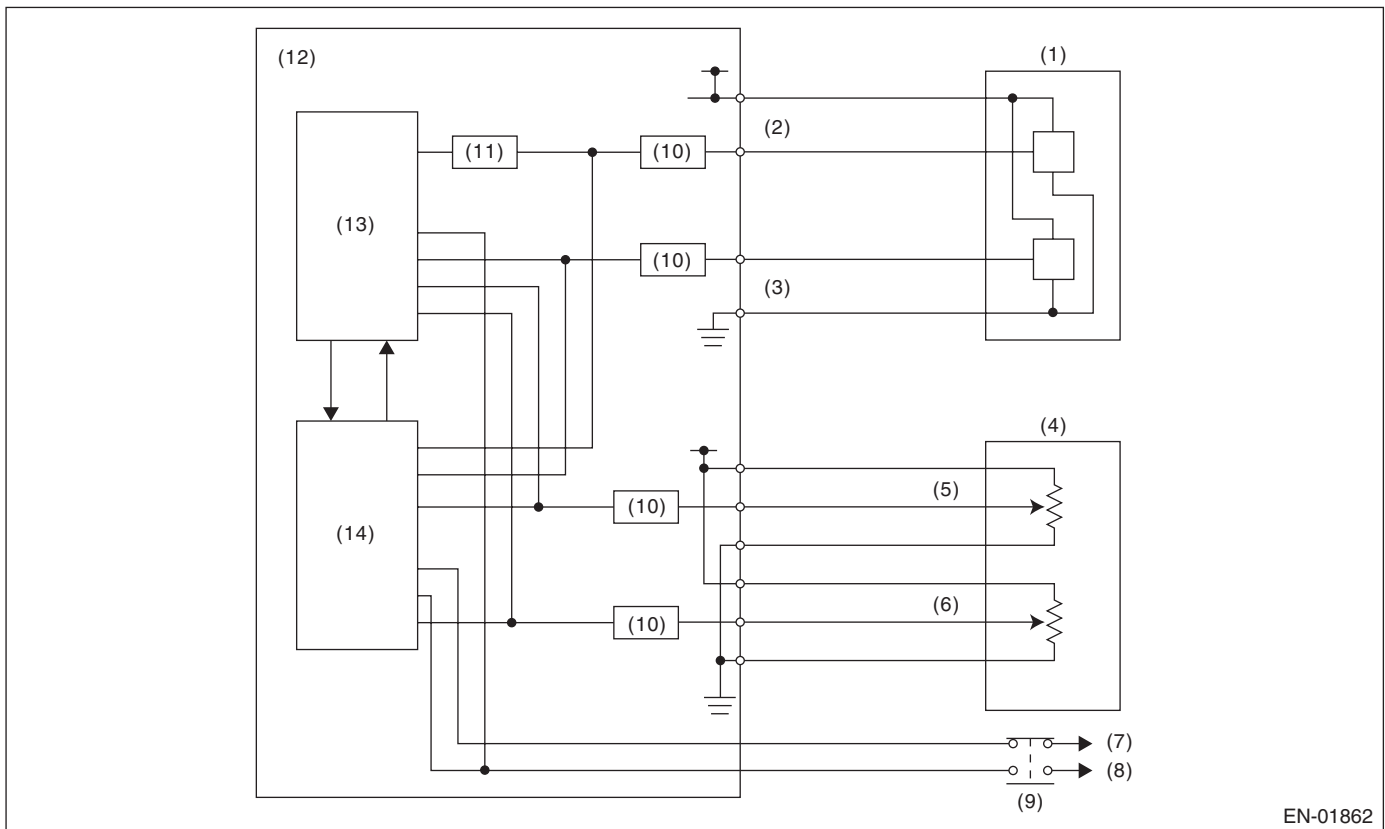

- |   |   |                                  |
|---|---|----------------------------------|
| (1) Throttle position sensor            | (6) Accelerator pedal position sensor 2 | (11) Amplifier circuit           |
| (2) Throttle position sensor 1          | (7) Battery                             | (12) Engine control module (ECM) |
| (3) Throttle position sensor 2          | (8) Stop light                          | (13) Sub CPU                     |
| (4) Accelerator pedal position sensor 1 | (9) Brake switch                        | (14) Main CPU                    |
| (5) Accelerator pedal position sensor 2 | (10) I/F circuit                        |                                  |

# Diagnostic Trouble Code (DTC) Detecting Criteria

## GENERAL DESCRIPTION

---

### 3. ENABLE CONDITION

Secondary Parameters	Enable Conditions
(1) Ignition switch	ON
(2) Ignition switch	ON
(3) None	—
(4) None	—
(5) Throttle opening angle	
(6) Brake SW (with cruise control)	ON
(7) None	—
(8) Cruise control	OFF

### 4. GENERAL DRIVING CYCLE

- (1) — (4): Always perform the diagnosis continuously.  
(5): Always perform the diagnosis continuously on idling.  
(6): Perform the diagnosis when the brake pedal is depressed.  
(7): Always perform the diagnosis continuously.  
(8): Always perform the diagnosis continuously when the cruise control pedal is not operating.

### 5. DIAGNOSTIC METHOD

Judge OK and clear NG when the malfunction criteria below are completed.

#### Judgment Value

Malfunction Criteria	Threshold Value
(1) Difference of CPU on reading value of throttle position sensor signal	0.0858 V
(2) Difference of CPU on reading value of accelerator pedal position sensor signal	0.038 V
(3) WD pulse from sub CPU	WD pulse occur
(4) Communication between CPU	Possible to communicate
(5) Throttle position sensor 1 opening angle – (Throttle position sensor 1 opening angle after amplifier passed) 1/4	< 3°
(6) Cruise control cancel signal at brake ON	Cruise control cancel signal ON
(7) Brake switch 1, 2 signal	SW 1 and 2 are matched

#### Time Needed for Diagnosis:

- (1) 250 milliseconds  
(2) 250 milliseconds  
(3) 200 milliseconds  
(4) 200 milliseconds  
(5) 24 milliseconds  
(6) 250 milliseconds  
(7) 200 milliseconds

**Malfunction Indicator Light Illumination:** Illuminates as soon as malfunction occurs.

### 6. DTC CLEAR CONDITION

- When the OK idling cycle was completed 40 times in a row
- When “Clear Memory” was performed

### 7. MALFUNCTION INDICATOR LIGHT CLEAR CONDITION

- When the OK driving cycle was completed 3 times in a row
- When “Clear Memory” was performed

# Diagnostic Trouble Code (DTC) Detecting Criteria

GENERAL DESCRIPTION

## 8. FAIL SAFE

Stop the current to electronic throttle control motor. (Fix the throttle opening angle to 6°.)

## 9. ECM OPERATION AT DTC SETTING

Memorize the freeze frame data. (For test mode \$02)

## CF:DTC P0638 THROTTLE ACTUATOR CONTROL RANGE/PERFORMANCE (BANK 1)

### 1. OUTLINE OF DIAGNOSIS

Judge NG when the target opening angle and actual opening angle is mismatched or the current to motor is more than specified duty for specified time continuously.

### 2. COMPONENT DESCRIPTION

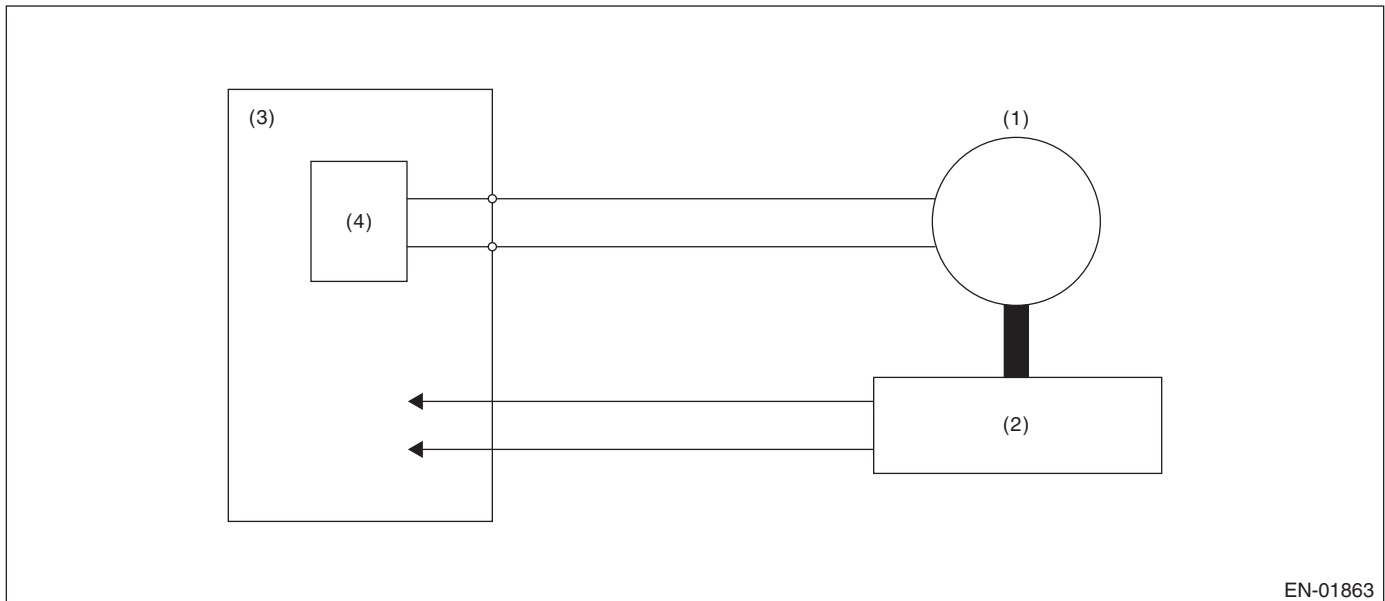

EN-01863

- (1) Motor  
(2) Throttle position sensor  
(3) Engine control module (ECM)  
(4) Drive circuit

### 3. ENABLE CONDITION

Secondary Parameters	Enable Conditions
Ignition switch	ON
Normal operation of electronic throttle control	ON

### 4. GENERAL DRIVING CYCLE

Always perform the diagnosis continuously when the electronic throttle control is operating.

### 5. DIAGNOSTIC METHOD

Judge OK and clear NG when the malfunction criteria below are completed.

#### Judgment Value

Malfunction Criteria	Threshold Value
Difference between target opening angle and actual opening angle	Less than 3.5°
Output duty to drive circuit	Less than 95%

# Diagnostic Trouble Code (DTC) Detecting Criteria

## GENERAL DESCRIPTION

### Time Needed for Diagnosis:

Target opening angle and actual opening angle: 250 milliseconds (For NG) 2,000 milliseconds (For OK)

Output duty to drive circuit: 2,000 milliseconds

### Details of Judgment

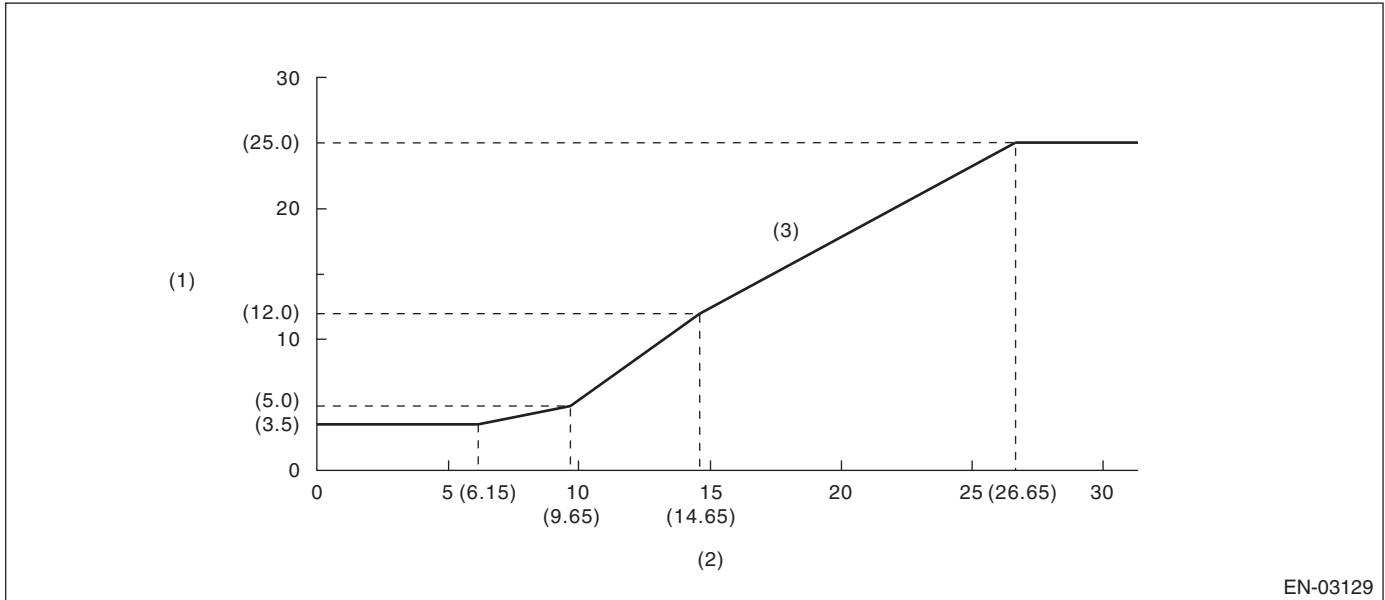

EN-03129

- (1) Difference between target opening angle and actual opening angle (°)      (2) Target throttle opening angle (°)  
 (3) NG area

### Details of Judgment (Always 1,000 milliseconds when the actual opening angle ≤ target opening angle)

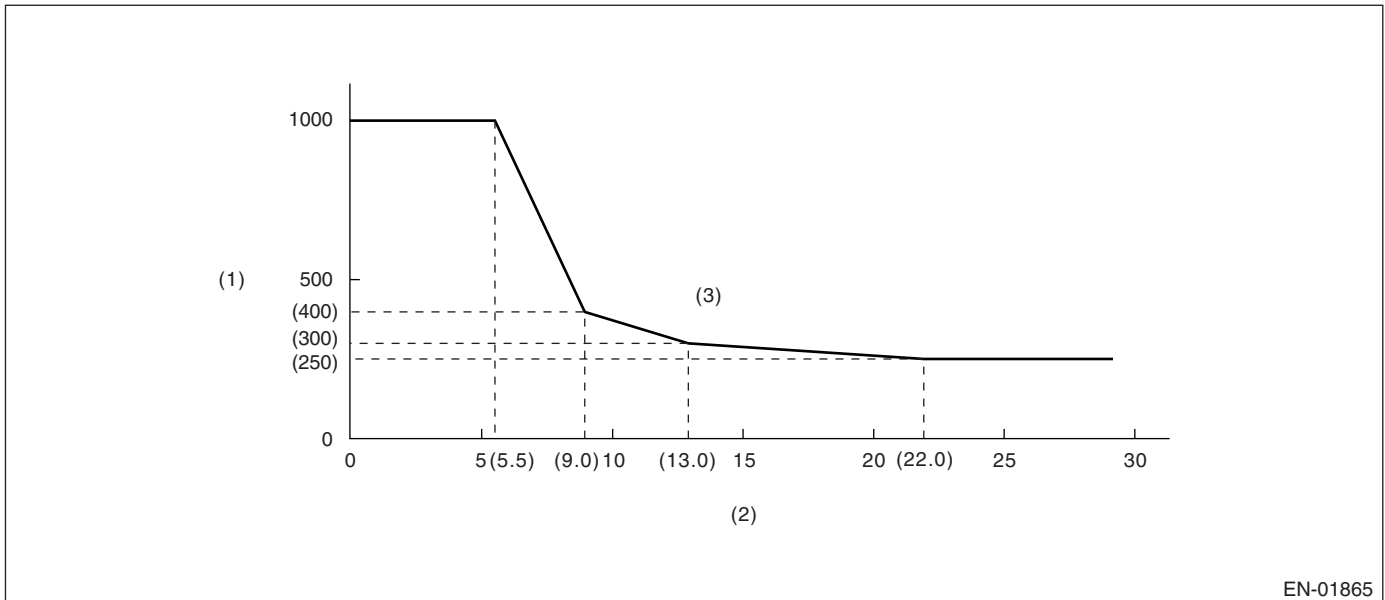

EN-01865

- (1) Judgment time (milliseconds)      (2) Throttle position sensor 1 opening angle      (3) NG area

**Malfunction Indicator Light Illumination:** Illuminates as soon as malfunction occurs.

## 6. DTC CLEAR CONDITION

- When the OK idling cycle was completed 40 times in a row
- When "Clear Memory" was performed (Only engine stopped)



# Diagnostic Trouble Code (DTC) Detecting Criteria

GENERAL DESCRIPTION

## 7. MALFUNCTION INDICATOR LIGHT CLEAR CONDITION

- When the OK driving cycle was completed 3 times in a row
- When "Clear Memory" was performed (Only engine stopped)

## 8. FAIL SAFE

Stop the current to electronic throttle control motor. (Fix the throttle opening angle to 6°.)

## 9. ECM OPERATION AT DTC SETTING

Memorize the freeze frame data. (For test mode \$02)

## CG:DTC P0691 COOLING FAN 1 CONTROL CIRCUIT LOW

### 1. OUTLINE OF DIAGNOSIS

Detect the open or short circuit of the radiator fan circuit.

Judge NG when the ECM output level differs from the actual terminal level.

### 2. ENABLE CONDITION

Secondary Parameters	Enable Conditions
None	

### 3. GENERAL DRIVING CYCLE

Always perform the diagnosis continuously.

### 4. DIAGNOSTIC METHOD

#### • Abnormality Judgment

Judge NG when the cumulative time of completing the malfunction criteria below becomes more than 2.5 seconds.

#### Judgment Value

Malfunction Criteria	Threshold Value
After starting the engine	1 seconds or more
Engine speed	≥ 500 rpm
Ignition switch	ON
Battery voltage	≥ 10.9 V
Terminal voltage level when ECM transmits OFF signal	Low level

**Time Needed for Diagnosis:** 2.5 seconds

**Malfunction Indicator Light Illumination:** Illuminates when malfunction occurs in 2 continuous driving cycles.

#### • Normality Judgment

Judge OK and clear NG when the malfunction criteria below are completed.

#### Judgment Value

Malfunction Criteria	Threshold Value
After starting the engine	1 seconds or more
Engine speed	≥ 500 rpm
Ignition switch	ON
Battery voltage	≥ 10.9 V
Terminal voltage level when ECM transmits OFF signal	High level

### 5. DTC CLEAR CONDITION

- When the OK idling cycle was completed 40 times in a row
- When "Clear Memory" was performed

# Diagnostic Trouble Code (DTC) Detecting Criteria

## GENERAL DESCRIPTION

---

### 6. MALFUNCTION INDICATOR LIGHT CLEAR CONDITION

- When the OK driving cycle was completed 3 times in a row
- When "Clear Memory" was performed

### 7. FAIL SAFE

None

### 8. ECM OPERATION AT DTC SETTING

Memorize the freeze frame data. (For test mode \$02)

## CH:DTC P0692 COOLING FAN 1 CONTROL CIRCUIT HIGH

### 1. OUTLINE OF DIAGNOSIS

Detect the open or short circuit of the radiator fan circuit.

Judge NG when the ECM output level differs from the actual terminal level.

### 2. ENABLE CONDITION

Secondary Parameters	Enable Conditions
None	

### 3. GENERAL DRIVING CYCLE

Always perform the diagnosis continuously.

### 4. DIAGNOSTIC METHOD

#### • Abnormality Judgment

Judge NG when the cumulative time of completing the malfunction criteria below becomes more than 2.5 seconds.

#### Judgment Value

Malfunction Criteria	Threshold Value
After starting the engine	1 seconds or more
Engine speed	≥ 500 rpm
Ignition switch	ON
Battery voltage	≥ 10.9 V
Terminal voltage level when ECM transmits ON signal	High level

**Time Needed for Diagnosis:** 2.5 seconds

**Malfunction Indicator Light Illumination:** Illuminates when malfunction occurs in 2 continuous driving cycles.

#### • Normality Judgment

Judge OK and clear NG when the malfunction criteria below are completed.

#### Judgment Value

Malfunction Criteria	Threshold Value
After starting the engine	1 seconds or more
Engine speed	≥ 500 rpm
Ignition switch	ON
Battery voltage	≥ 10.9 V
Terminal voltage level when ECM transmits ON signal	Low level

### 5. DTC CLEAR CONDITION

- When the OK idling cycle was completed 40 times in a row
- When "Clear Memory" was performed

# Diagnostic Trouble Code (DTC) Detecting Criteria

GENERAL DESCRIPTION

## 6. MALFUNCTION INDICATOR LIGHT CLEAR CONDITION

- When the OK driving cycle was completed 3 times in a row
- When "Clear Memory" was performed

## 7. FAIL SAFE

None

## 8. ECM OPERATION AT DTC SETTING

Memorize the freeze frame data. (For test mode \$02)

## CI: DTC P0700 TRANSMISSION CONTROL SYSTEM (MIL REQUEST)

### 1. OUTLINE OF DIAGNOSIS

AT C/U performs CAN communication. It judges as NG if malfunction is detected.

### 2. ENABLE CONDITION

Secondary Parameters	Enable Conditions
Battery Voltage	$\geq 10.9$ V

### 3. GENERAL DRIVING CYCLE

Always perform diagnosis continuously.

### 4. DIAGNOSTIC METHOD

Judge NG when the continuous time of completing the malfunction criteria below becomes more than 2.5 seconds. Judge OK and clear the NG when the malfunction criteria below are not completed.

#### Judgement Value

Malfunction Criteria	Threshold Value
MIL light up request from TCM	Set

**Time needed for diagnosis:**2.5 seconds

**Malfunction Indicator Light Illumination:**Illuminates simultaneously when malfunction is detected.

### 5. DTC CLEAR CONDITION

- When the OK driving cycle was completed 40 consecutive times.
- When "Clear Memory" was performed.

## 6. MALFUNCTION INDICATOR LIGHT CLEAR CONDITION

- When the OK driving cycle was completed 3 consecutive times.
- When "Clear Memory" was performed.

## 7. FAIL-SAFE

None

## 8. ECM OPERATING AT DTC SETTING

Store the freeze frame data. (For test mode \$02)

# Diagnostic Trouble Code (DTC) Detecting Criteria

## GENERAL DESCRIPTION

---

### CJ:DTC P0851 NEUTRAL SWITCH INPUT CIRCUIT LOW (AT MODEL)

#### 1. OUTLINE OF DIAGNOSIS

Detect the open or short circuit of the neutral SW.

Judge NG when the ECM neutral terminal input differs from the reception data from TCM.

#### 2. ENABLE CONDITION

Secondary Parameters	Enable Conditions
Ignition switch	ON
Battery voltage	$\geq 10.9 \text{ V}$
After starting the engine	2 seconds or more
Starter switch	OFF

#### 3. GENERAL DRIVING CYCLE

Perform the diagnosis continuously in 2 seconds or more after starting the engine.

#### 4. DIAGNOSTIC METHOD

Judge NG when the continuous time of completing the malfunction criteria below becomes more than 2.56 seconds. Judge OK and clear NG when the malfunction criteria below are not completed.

##### Judgment Value

Malfunction Criteria	Threshold Value
Neutral switch signal when park/neutral = "OFF" & any other switches = "ON" on AT	LOW (ON)

**Time Needed for Diagnosis:** 2.56 seconds

**Malfunction Indicator Light Illumination:** Illuminates when malfunction occurs in 2 continuous driving cycles.

#### 5. DTC CLEAR CONDITION

- When the OK idling cycle was completed 40 times in a row
- When "Clear Memory" was performed

#### 6. MALFUNCTION INDICATOR LIGHT CLEAR CONDITION

- When the OK driving cycle was completed 3 times in a row
- When "Clear Memory" was performed

#### 7. FAIL SAFE

Cruise control: Not allowed to command cruise control.

#### 8. ECM OPERATION AT DTC SETTING

Memorize the freeze frame data. (For test mode \$02)

# Diagnostic Trouble Code (DTC) Detecting Criteria

GENERAL DESCRIPTION

## CK:DTC P0851 NEUTRAL SWITCH INPUT CIRCUIT LOW (MT MODEL)

### 1. OUTLINE OF DIAGNOSIS

Judge the open or short circuit of the neutral SW.

Judge NG when there is no change in the neutral SW even if the driving shift was applied. (There is neutral SW ON/OFF inversion from the vehicle speed and engine speed.)

### 2. ENABLE CONDITION

Secondary Parameters	Enable Conditions
Ignition switch	ON
Battery voltage	$\geq 10.9 \text{ V}$
After starting the engine	2 seconds or more
Starter switch	OFF

### 3. GENERAL DRIVING CYCLE

Perform the diagnosis continuously in 2 seconds or more after starting the engine.

### 4. DIAGNOSTIC METHOD

Judge NG when the malfunction criteria below are completed 3 time or more after the neutral SW change.

Judge OK and clear NG if there is change in the neutral SW.

#### Judgment Value

Malfunction Criteria	Threshold Value
Neutral switch signal (while changing from a to b below)	LOW (ON)
Driving condition change	a) to b)
a) Vehicle speed = 0 km/h (0 MPH) & engine speed 600 — 900 rpm	
b) Vehicle speed $\geq 64 \text{ km/h}$ (40 MPH) & engine speed 1,600 — 2,550 rpm	

**Time Needed for Diagnosis:** 3 monitoring

**Malfunction Indicator Light Illumination:** Illuminates when malfunction occurs in 2 continuous driving cycles.

### 5. DTC CLEAR CONDITION

- When the OK idling cycle was completed 40 times in a row
- When "Clear Memory" was performed

### 6. MALFUNCTION INDICATOR LIGHT CLEAR CONDITION

- When the OK driving cycle was completed 3 times in a row
- When "Clear Memory" was performed

### 7. FAIL SAFE

Cruise control: Not allowed to command cruise control.

### 8. ECM OPERATION AT DTC SETTING

Memorize the freeze frame data. (For test mode \$02)

# Diagnostic Trouble Code (DTC) Detecting Criteria

## GENERAL DESCRIPTION

---

### CL:DTC P0852 NEUTRAL SWITCH INPUT CIRCUIT HIGH (AT MODEL)

#### 1. OUTLINE OF DIAGNOSIS

Detect the open or short circuit of the neutral SW.

Judge NG when the ECM neutral terminal input differs from the reception data from TCM.

#### 2. ENABLE CONDITION

Secondary Parameters	Enable Conditions
Ignition switch	ON
Battery voltage	$\geq 10.9 \text{ V}$
After starting the engine	2 seconds or more
Starter switch	OFF

#### 3. GENERAL DRIVING CYCLE

Perform the diagnosis continuously in 2 seconds or more after starting the engine.

#### 4. DIAGNOSTIC METHOD

Judge NG when the continuous time until completing the malfunction criteria below becomes more than 2.56 seconds. Judge OK and clear NG when the malfunction criteria below are not completed.

##### Judgment Value

Malfunction Criteria	Threshold Value
Neutral switch signal when park/neutral = "ON" & any other switches = "OFF" on AT	HIGH (OFF)

**Time Needed for Diagnosis:** 2.56 seconds

**Malfunction Indicator Light Illumination:** Illuminates when malfunction occurs in 2 continuous driving cycles.

#### 5. DTC CLEAR CONDITION

- When the OK idling cycle was completed 40 times in a row
- When "Clear Memory" was performed

#### 6. MALFUNCTION INDICATOR LIGHT CLEAR CONDITION

- When the OK driving cycle was completed 3 times in a row
- When "Clear Memory" was performed

#### 7. FAIL SAFE

Cruise control: Not allowed to command cruise control.

#### 8. ECM OPERATION AT DTC SETTING

Memorize the freeze frame data. (For test mode \$02)

# Diagnostic Trouble Code (DTC) Detecting Criteria

GENERAL DESCRIPTION

## CM:DTC P0852 NEUTRAL SWITCH INPUT CIRCUIT HIGH (MT MODEL)

### 1. OUTLINE OF DIAGNOSIS

Judge the open or short circuit of the neutral SW.

Judge NG when there is no change in the neutral SW even if the driving shift was applied. (There is neutral SW ON/OFF inversion from the vehicle speed and engine speed.)

### 2. ENABLE CONDITION

Secondary Parameters	Enable Conditions
Ignition switch	ON
Battery voltage	$\geq 10.9 \text{ V}$
After starting the engine	2 seconds or more
Starter switch	OFF

### 3. GENERAL DRIVING CYCLE

Perform the diagnosis continuously in 2 seconds or more after starting the engine.

### 4. DIAGNOSTIC METHOD

Judge NG when the malfunction criteria below are completed 3 time or more after the neutral SW change. Judge OK and clear NG if there is change in the neutral SW.

#### Judgment Value

Malfunction Criteria	Threshold Value
Neutral switch signal (while changing from a to b below)	HIGH (OFF)
Driving condition change	a) to b)
a) Vehicle speed = 0 km/h (0 MPH) & engine speed 600 — 900 rpm	
b) Vehicle speed $\geq 64 \text{ km/h}$ (40 MPH) & engine speed 1,600 — 2,550 rpm	

**Time Needed for Diagnosis:** 3 monitoring

**Malfunction Indicator Light Illumination:** Illuminates when malfunction occurs in 2 continuous driving cycles.

### 5. DTC CLEAR CONDITION

- When the OK idling cycle was completed 40 times in a row
- When "Clear Memory" was performed

### 6. MALFUNCTION INDICATOR LIGHT CLEAR CONDITION

- When the OK driving cycle was completed 3 times in a row
- When "Clear Memory" was performed

### 7. FAIL SAFE

Cruise control: Not allowed to command cruise control.

### 8. ECM OPERATION AT DTC SETTING

Memorize the freeze frame data. (For test mode \$02)

# Diagnostic Trouble Code (DTC) Detecting Criteria

## GENERAL DESCRIPTION

### CN:DTC P1152 O<sub>2</sub> SENSOR CIRCUIT RANGE/PERFORMANCE (LOW) (BANK1 SENSOR1)

#### 1. OUTLINE OF DIAGNOSIS

Detect that lambda value remains Low.

Judge NG when lambda value is abnormal in accordance with lambda value of front oxygen (A/F) sensor and running condition that is vehicle speed, amount of intake air engine coolant temperature, sub feedback control, etc.

**Lambda value = Actual air fuel ratio/Theoretical air fuel ratio**

Lambda > 1: Lean

Lambda < 1: Rich

#### 2. COMPONENT DESCRIPTION

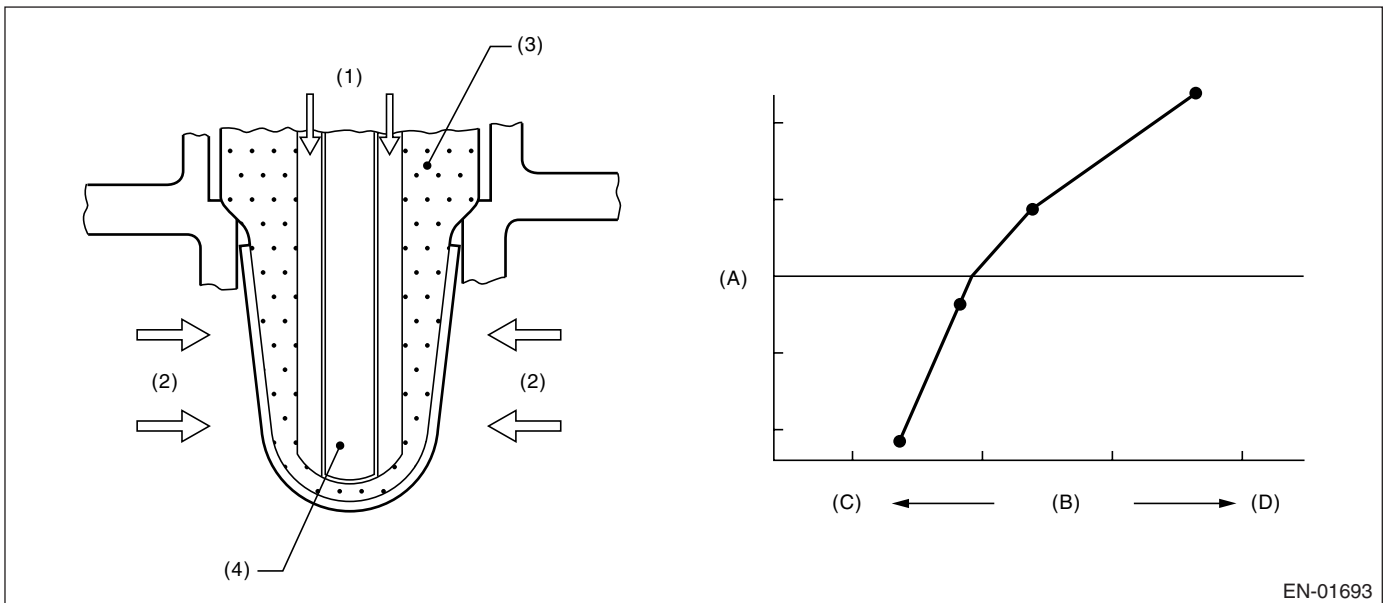

EN-01693

- (1) Atmosphere
- (2) Exhaust
- (3) ZrO<sub>2</sub>
- (4) Ceramic heater

- (A) Electromotive force
- (B) Air fuel ratio
- (C) Lean
- (D) Rich



# Diagnostic Trouble Code (DTC) Detecting Criteria

GENERAL DESCRIPTION

## 3. ENABLE CONDITION

Secondary Parameters	Enable Conditions
All secondary parameters to be in enable conditions	4 seconds or more
Battery voltage	> 10.9 V
Atmospheric pressure	> 75.1 kPa (563 mmHg, 22.2 inHg)
Rear oxygen sensor sub feedback	Operating
Rear oxygen sensor output voltage – feedback target voltage	–0.2 V ↔ 0.1 V
or rear oxygen sensor sub feedback compensation coefficient	On Min.
or rear oxygen sensor sub feedback compensation coefficient	On Max.
After engine starting	60 seconds or more
Engine coolant temperature	≥ 75°C (167°F)
Vehicle speed	≥ 20 km/h (12 MPH)
Amount of intake air	≥ 6 g (0.21 oz)/s
Load change during 0.5 engine rev.	≤ 0.02 g (0.001 oz)/rev
Impedance of front oxygen (A/F) sensor	0 ↔ 50 Ω
Learning value of evaporation gas density	≤ 0.2
Total time of operating canister purge	20 seconds or more
Target lambda load compensation coefficient	–0.03 ↔ 0

## 4. GENERAL DRIVING CYCLE

Perform diagnosis continuously at a constant speed of 20 km/h (12 MPH) or more since 60 seconds after starting the engine.

## 5. DIAGNOSTIC METHOD

Judge NG when the continuous time of completing the malfunction criteria below becomes more than 10 seconds. Judge OK and clear NG when the malfunction criteria below are not completed.

### Judgment Value

Malfunction Criteria	Threshold Value
Output lambda when rear oxygen sensor sub feedback compensation coefficient being at not high limit	≤ 0.85

**Time Needed for Diagnosis:** 10 seconds

**Malfunction Indicator Light Illumination:** Illuminates when malfunction occurs in 2 continuous driving cycles.

## 6. DTC CLEAR CONDITION

- When the OK idling cycle was completed 40 times in a row
- When “Clear Memory” was performed

## 7. MALFUNCTION INDICATOR LIGHT CLEAR CONDITION

- When the OK driving cycle was completed 3 times in a row
- When “Clear Memory” was performed

## 8. FAIL SAFE

- Front oxygen (A/F) sensor main learning compensation: Not allowed to calculate
- Front oxygen (A/F) sensor sub learning compensation: Not allowed to calculate
- Purge control: Not allowed to purge

# Diagnostic Trouble Code (DTC) Detecting Criteria

## GENERAL DESCRIPTION

### 9. ECM OPERATION AT DTC SETTING

Memorize the freeze frame data. (For test mode \$02)

## CO:DTC P1153 O<sub>2</sub> SENSOR CIRCUIT RANGE/PERFORMANCE (HIGH) (BANK1 SENSOR1)

### 1. OUTLINE OF DIAGNOSIS

Detect that lambda value remains High.

Judge NG when lambda value is abnormal in accordance with lambda value of front oxygen (A/F) sensor and running condition that is vehicle speed, amount of intake air engine coolant temperature, sub feedback control, etc.

**Lambda value = Actual air fuel ratio/Theoretical air fuel ratio**

Lambda > 1: Lean

Lambda < 1: Rich

### 2. COMPONENT DESCRIPTION

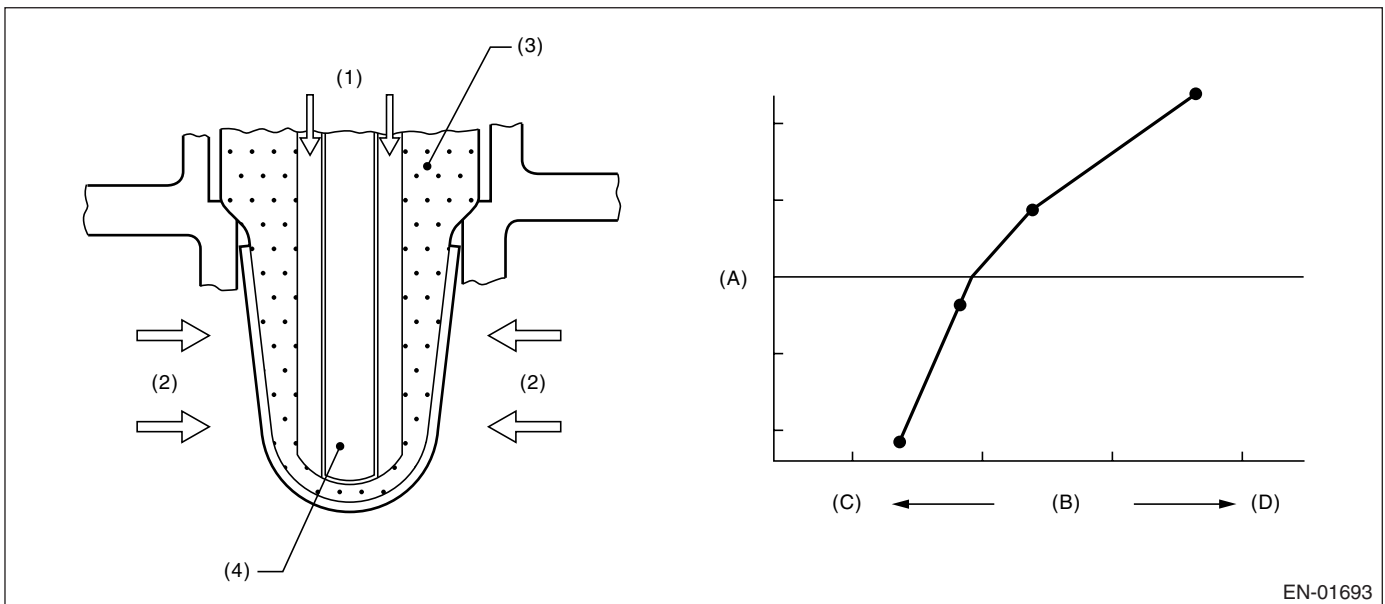

EN-01693

- (1) Atmosphere
- (2) Exhaust
- (3) ZrO<sub>2</sub>
- (4) Ceramic heater

- (A) Electromotive force
- (B) Air fuel ratio
- (C) Lean
- (D) Rich

# Diagnostic Trouble Code (DTC) Detecting Criteria

GENERAL DESCRIPTION

## 3. ENABLE CONDITION

Secondary Parameters	Enable Conditions
All secondary parameters to be in enable conditions	4 seconds or more
Battery voltage	> 10.9 V
Atmospheric pressure	> 75.1 kPa (563 mmHg, 22.2 inHg)
Rear oxygen sensor sub feedback	Operating
Rear oxygen sensor output voltage – feedback target voltage	–0.2 V ↔ 0.1 V
or rear oxygen sensor sub feedback compensation coefficient	On Min.
or rear oxygen sensor sub feedback compensation coefficient	On Max.
After engine starting	60 seconds or more
Engine coolant temperature	≥ 75°C (167°F)
Vehicle speed	≥ 20 km/h (12 MPH)
Amount of intake air	≥ 6 g (0.21 oz)/s
Load change during 0.5 engine rev.	≤ 0.02 g (0.001 oz)/rev
Impedance of front oxygen (A/F) sensor	0 ↔ 50 Ω
Learning value of evaporation gas density	≤ 0.2
Total time of operating canister purge	20 seconds or more
Target lambda load compensation coefficient	–0.03 ↔ 0

## 4. GENERAL DRIVING CYCLE

Perform diagnosis continuously at a constant speed of 20 km/h (12 MPH) or more since 60 seconds after starting the engine.

## 5. DIAGNOSTIC METHOD

Judge NG when the continuous time of completing the malfunction criteria below becomes more than 10 seconds. Judge OK and clear NG when the malfunction criteria below are not completed.

### Judgment Value

Malfunction Criteria	Threshold Value
Output lambda when rear O <sub>2</sub> sensor sub feedback compensation coefficient value being at not low limit	≥ 1.15

**Time Needed for Diagnosis:** 10 seconds

**Malfunction Indicator Light Illumination:** Illuminates when malfunction occurs in 2 continuous driving cycles.

## 6. DTC CLEAR CONDITION

- When the OK idling cycle was completed 40 times in a row
- When “Clear Memory” was performed

## 7. MALFUNCTION INDICATOR LIGHT CLEAR CONDITION

- When the OK driving cycle was completed 3 times in a row
- When “Clear Memory” was performed

## 8. FAIL SAFE

- Front oxygen (A/F) sensor main learning compensation: Not allowed to calculate
- Front oxygen (A/F) sensor sub learning compensation: Not allowed to calculate.
- Purge control: Not allowed to purge

# Diagnostic Trouble Code (DTC) Detecting Criteria

## GENERAL DESCRIPTION

### 9. ECM OPERATION AT DTC SETTING

Memorize the freeze frame data. (For test mode \$02)

### CP:DTC P1160 RETURN SPRING FAILURE

#### 1. OUTLINE OF DIAGNOSIS

Judge NG when the valve does not move to the close direction with the motor power stopped and the valve open more than the default opening.

#### 2. COMPONENT DESCRIPTION

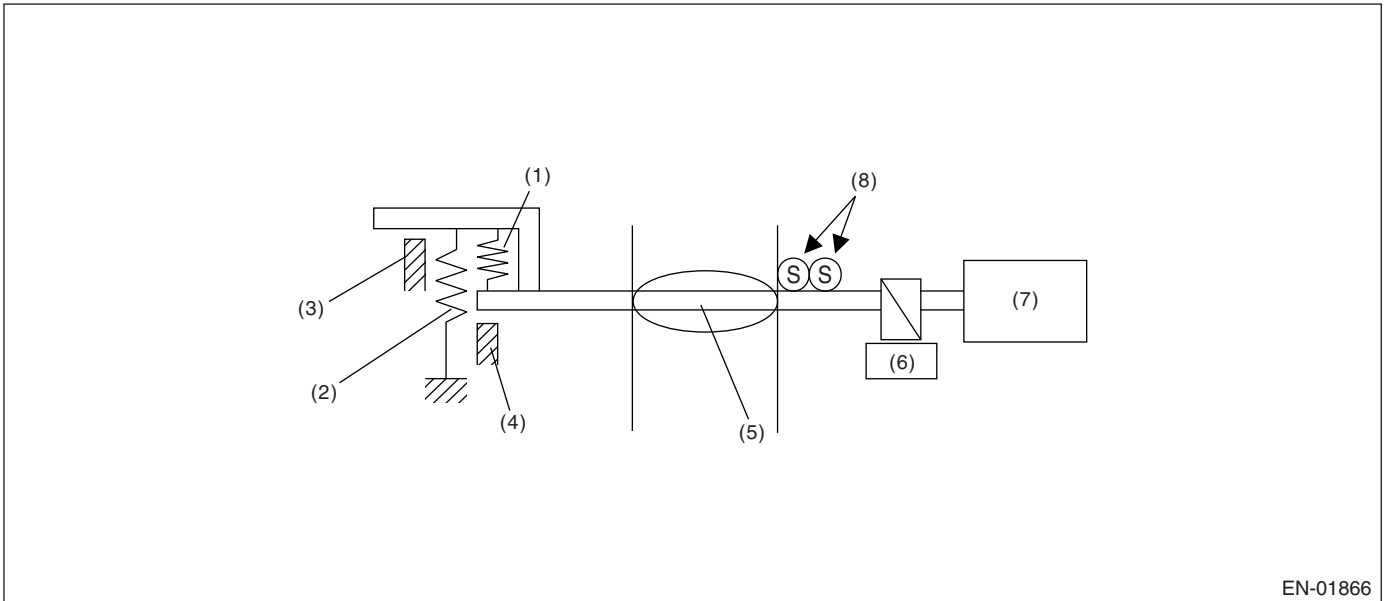

EN-01866

- |                          |                         |                                  |
|--------------------------|-------------------------|----------------------------------|
| (1) Opener spring        | (4) Full closed stopper | (7) DC motor                     |
| (2) Return spring        | (5) Throttle valve      | (8) Main and sub throttle sensor |
| (3) Intermediate stopper | (6) Gear                |                                  |

#### 3. ENABLE CONDITION

Secondary Parameters	Enable Conditions
Throttle opening	OFF
Motor continuity	OFF

#### 4. GENERAL DRIVING CYCLE

- Ignition switch ON → OFF
- Ignition switch OFF → ON (After clear memory only)

#### 5. DIAGNOSTIC METHOD

Judge OK and clear the NG when the malfunction criteria below are completed.

##### Judgment Value

Malfunction Criteria	Threshold Value
Opening variation after continuity is set to OFF	$\geq 2^\circ$

**Time Needed for Diagnosis:** 1,880 milliseconds

**Malfunction Indicator Light Illumination:** Illuminates as soon as malfunction occurs.

#### 6. DTC CLEAR CONDITION

- When the OK idling cycle was completed 40 times in a row
- When "Clear Memory" was performed (Only with engine stopped)

# Diagnostic Trouble Code (DTC) Detecting Criteria

GENERAL DESCRIPTION

## 7. MALFUNCTION INDICATOR LIGHT CLEAR CONDITION

- When the OK driving cycle was completed 3 times in a row
- When "Clear Memory" was performed (Only with engine stopped)

## 8. FAIL SAFE

Fix the throttle opening to 6°.

## 9. ECM OPERATION AT DTC SETTING

Memorize the freeze frame data. (For test mode \$02)

## CQ:DTC P1400 FUEL TANK PRESSURE CONTROL SOLENOID VALVE CIRCUIT LOW

### 1. OUTLINE OF DIAGNOSIS

Detect open or short circuit of pressure control solenoid valve. Judge NG when ECM output level is different from actual terminal level.

### 2. COMPONENT DESCRIPTION

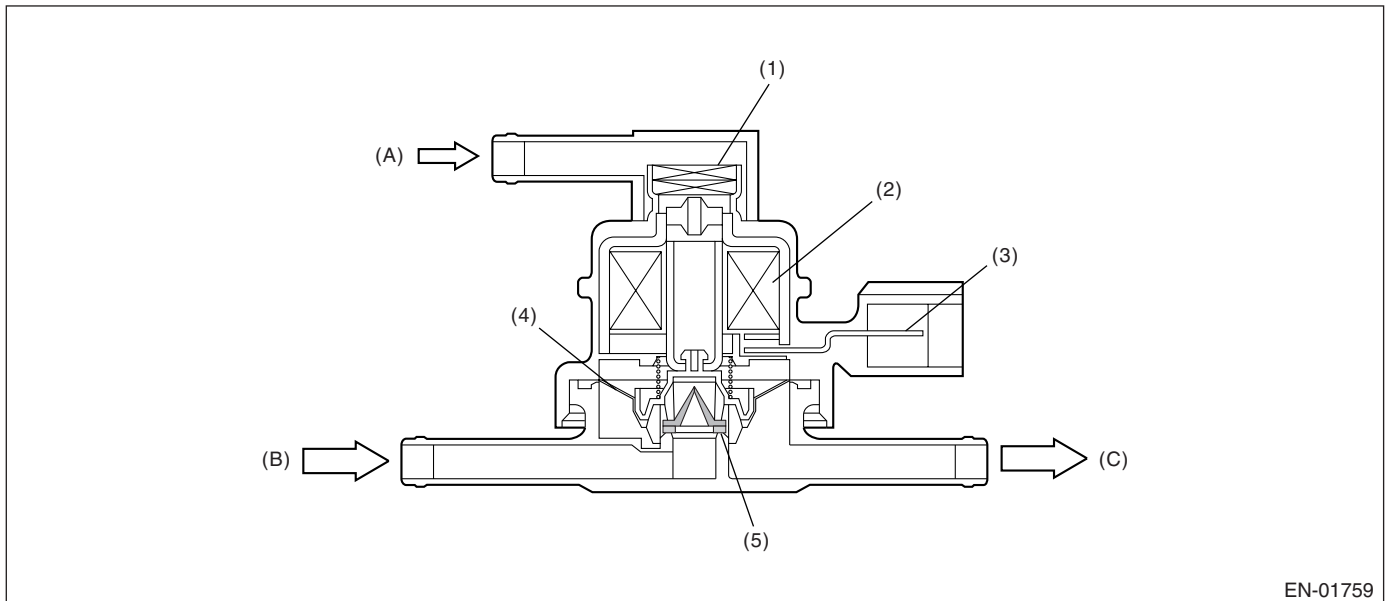

EN-01759

- |                        |               |                          |
|------------------------|---------------|--------------------------|
| (1) Filter             | (4) Diaphragm | (A) Atmospheric pressure |
| (2) Coil               | (5) Valve     | (B) Shut off valve       |
| (3) Connector terminal |               | (C) To fuel tank         |

### 3. ENABLE CONDITION

Secondary Parameters	Enable Conditions
Ignition switch	ON
Battery voltage	≥ 10.9 V
After engine starting	1 second or more

### 4. GENERAL DRIVING CYCLE

Always perform the diagnosis after starting the engine.

# Diagnostic Trouble Code (DTC) Detecting Criteria

## GENERAL DESCRIPTION

---

### 5. DIAGNOSTIC METHOD

Judge NG when the continuous time of completing the malfunction criteria below becomes more than 2.5 seconds. Judge OK and clear the NG when the malfunction criteria below are not completed.

#### Judgment Value

Malfunction Criteria	Threshold Value
Terminal voltage when ECM outputs off signal	Low

**Time Needed for Diagnosis:** 2.5 seconds

**Malfunction Indicator Light Illumination:** Illuminates when malfunction occurs in two continuous drive cycles.

### 6. DTC CLEAR CONDITION

- When the OK idling cycle was completed 40 times in a row
- When "Clear Memory" was performed

### 7. MALFUNCTION INDICATOR LIGHT CLEAR CONDITION

- When the OK driving cycle was completed 3 times in a row
- When "Clear Memory" was performed

### 8. FAIL SAFE

None

### 9. ECM OPERATION AT DTC SETTING

Memorize the freeze frame data. (For test mode \$02)

## CR:DTC P1420 FUEL TANK PRESSURE CONTROL SOL. VALVE CIRCUIT HIGH

### 1. OUTLINE OF DIAGNOSIS

Detect open or short circuit of pressure control solenoid valve.  
 Judge NG when ECM output level is different from actual terminal level.

### 2. COMPONENT DESCRIPTION

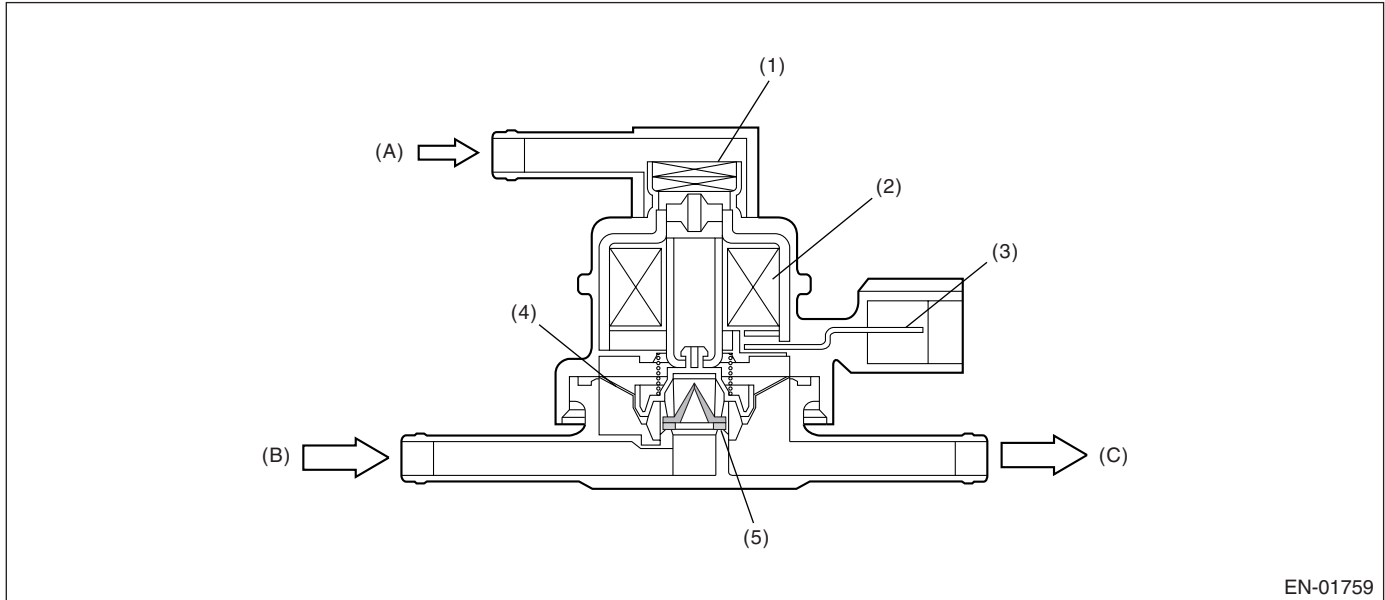

EN-01759

- |                        |               |                          |
|------------------------|---------------|--------------------------|
| (1) Filter             | (4) Diaphragm | (A) Atmospheric pressure |
| (2) Coil               | (5) Valve     | (B) Shut off valve       |
| (3) Connector terminal |               | (C) To fuel tank         |

### 3. ENABLE CONDITION

Secondary Parameters	Enable Conditions
Ignition switch	ON
Battery voltage	≥ 10.9 V
After engine starting	1 second or more

### 4. GENERAL DRIVING CYCLE

Always perform the diagnosis after starting the engine.

### 5. DIAGNOSTIC METHOD

Judge NG when the continuous time of completing the malfunction criteria below becomes more than 2.5 seconds. Judge OK and clear the NG when the malfunction criteria below are not completed.

#### Judgment Value

Malfunction Criteria	Threshold Value
Terminal voltage when ECM outputs off signal	High

**Time Needed for Diagnosis:** 2.5 seconds

**Malfunction Indicator Light Illumination:** Illuminates when malfunction occurs in two continuous drive cycles.

### 6. DTC CLEAR CONDITION

- When the OK idling cycle was completed 40 times in a row
- When "Clear Memory" was performed

# Diagnostic Trouble Code (DTC) Detecting Criteria

## GENERAL DESCRIPTION

### 7. MALFUNCTION INDICATOR LIGHT CLEAR CONDITION

- When the OK driving cycle was completed 3 times in a row
- When "Clear Memory" was performed

### 8. FAIL SAFE

None

### 9. ECM OPERATION AT DTC SETTING

Memorize the freeze frame data. (For test mode \$02)

## CS:DTC P1443 VENT CONTROL SOLENOID VALVE FUNCTION PROBLEM

### 1. OUTLINE OF DIAGNOSIS

Detect the drain valve function abnormality.

Judge NG when the fuel tank pressure is small.

### 2. COMPONENT DESCRIPTION

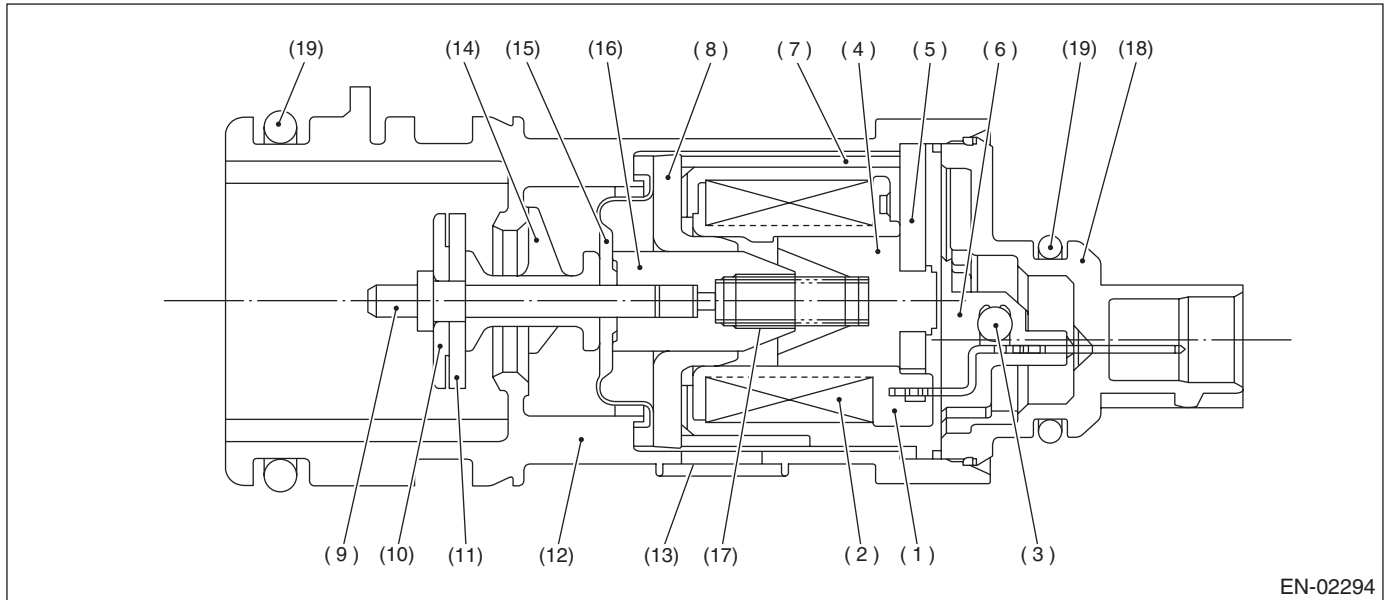

EN-02294

- |                 |                    |                   |
|-----------------|--------------------|-------------------|
| (1) Bobbin      | (8) Magnetic plate | (15) Diaphragm    |
| (2) Coil        | (9) Shaft          | (16) Movable core |
| (3) Diode       | (10) Plate         | (17) Spring       |
| (4) Stator core | (11) Valve         | (18) Cover        |
| (5) End plate   | (12) Housing       | (19) O-ring       |
| (6) Body        | (13) Filter        |                   |
| (7) Yoke        | (14) Retainer      |                   |

### 3. ENABLE CONDITION

Secondary Parameter	Enable Condition
Drain valve	Open
Battery voltage	$\geq 10.9 \text{ V}$
Atmospheric pressure	$\geq 75.0 \text{ kPa}$ (563 mmHg, 22.17 inHg)
Tank pressure when starter ON → OFF	$-0.7 \leftrightarrow 1.4 \text{ kPa}$ ( $-5 \leftrightarrow 10.7 \text{ mmHg}$ , $-0.20 \leftrightarrow 0.42 \text{ inHg}$ )



# Diagnostic Trouble Code (DTC) Detecting Criteria

GENERAL DESCRIPTION

## 4. GENERAL DRIVING CYCLE

Always perform the diagnosis continuously.

## 5. DIAGNOSTIC METHOD

### • Abnormality Judgment

Judge NG when the continuous time of completing the malfunction criteria below becomes more than 3 seconds.

### Judgment Value

Malfunction Criteria	Threshold Value
Tank pressure	$\leq -4.0$ kPa ( $-30$ mmHg, $-1.18$ inHg)

**Time Needed for Diagnosis:** 3 seconds

**Malfunction Indicator Light Illumination:** Illuminates as soon as the malfunction occurs.

### • Normality Judgment

Judge OK and clear the NG when the malfunction criteria below are completed.

### Judgment Value

Malfunction Criteria	Threshold Value
Tank pressure	$> -4.0$ kPa ( $-30$ mmHg, $-1.18$ inHg)
Cumulative time when the malfunction criteria below are completed	$\geq 30$ seconds
Duty ratio of purge control solenoid valve	Except 0
Fuel temperature	$-10 \leftrightarrow 45^{\circ}\text{C}$ ( $14 \leftrightarrow 113^{\circ}\text{F}$ )
Relative ratio of intake manifold	$\leq -26.7$ kPa ( $-200$ mmHg, $-7.87$ inHg)

## 6. DTC CLEAR CONDITION

- When the OK idling cycle was completed 40 times in a row
- When "Clear Memory" was performed

## 7. MALFUNCTION INDICATOR LIGHT CLEAR CONDITION

- When the OK driving cycle was completed 3 times in a row
- When "Clear Memory" was performed

## 8. FAIL SAFE

PCV control: Open the PCV solenoid.

## 9. ECM OPERATION AT DTC SETTING

Memorize the freeze frame data. (For test mode \$02)

# Diagnostic Trouble Code (DTC) Detecting Criteria

## GENERAL DESCRIPTION

### CT:DTC P1491 POSITIVE CRANKCASE VENTILATION (BLOW-BY) FUNCTION PROBLEM

#### 1. OUTLINE OF DIAGNOSIS

Detect the blow-by hose release abnormality.  
Judge NG when the diagnosis terminal voltage is high.

#### 2. COMPONENT DESCRIPTION

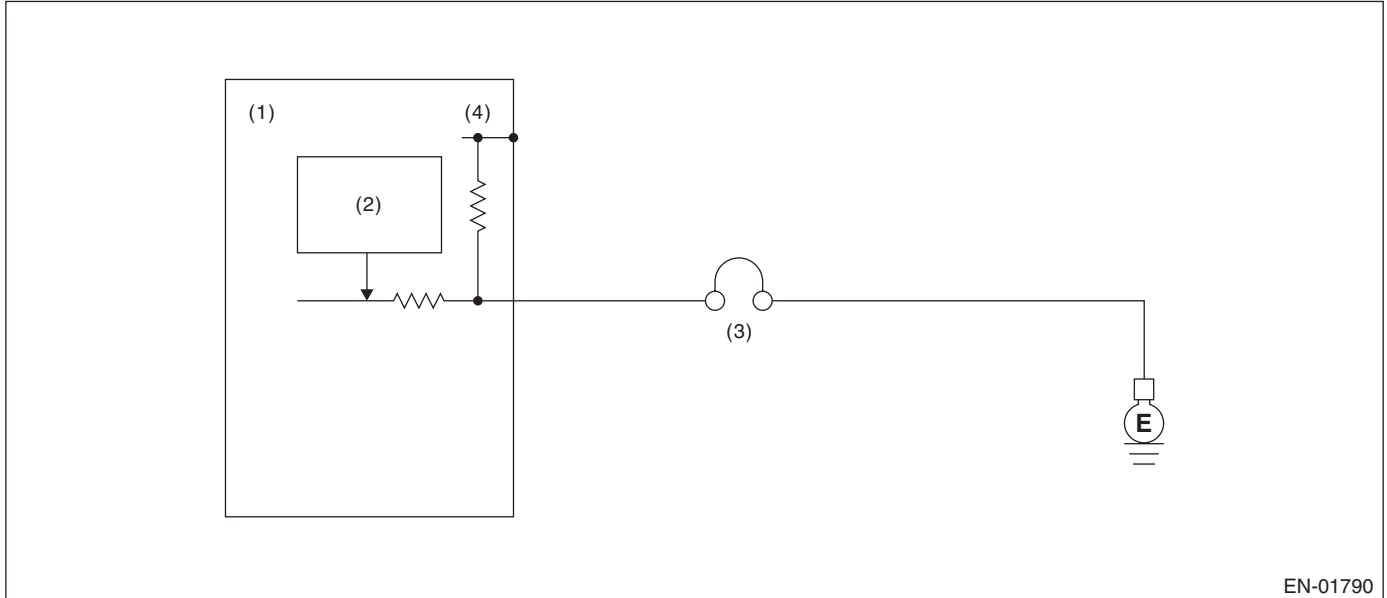

- (1) Engine control module (ECM)
- (2) Detecting circuit
- (3) PCV diagnosis connector
- (4) 5 V

#### 3. ENABLE CONDITION

Secondary Parameter	Enable Condition
None	

#### 4. GENERAL DRIVING CYCLE

Always perform the diagnosis continuously.

#### 5. DIAGNOSIS METHOD

##### • Abnormality Judgment

Judge NG when the continuous time until completing the malfunction criteria below becomes more than 2.5 second.

##### Judgment Value

Malfunction Criteria	Threshold Value
Battery voltage	> 10.9 V
Positive crankcase ventilation diagnosis terminal voltage	High
Engine speed	≥ 500 rpm

**Time Needed for Diagnosis:** 2.5 second

**Malfunction Indicator Light Illumination:** Illuminates as soon as malfunction occurs.

# Diagnostic Trouble Code (DTC) Detecting Criteria

GENERAL DESCRIPTION

## • Normality Judgment

Judge OK and clear NG when the malfunction criteria below is completed.

### Judgment Value

Malfunction Criteria	Threshold Value
Battery voltage	> 10.9 V
Positive crankcase ventilation diagnosis terminal voltage	Low
Engine speed	≥ 500 rpm

## 6. DTC CLEAR CONDITION

- When the OK idling cycle was completed 40 times in a row
- When "Clear Memory" was performed

## 7. MALFUNCTION INDICATOR LIGHT CLEAR CONDITION

- When the OK driving cycle was performed 3 times in a row
- When "Clear Memory" was performed

## 8. FAIL SAFE

None

## 9. ECM OPERATION AT DTC SETTING

Memorize the freeze frame data. (For test mode \$02)

# Diagnostic Trouble Code (DTC) Detecting Criteria

## GENERAL DESCRIPTION

### CU:DTC P1492 EGR SOLENOID VALVE SIGNAL #1 CIRCUIT MALFUNCTION (LOW INPUT)

#### 1. OUTLINE OF DIAGNOSIS

- Detect the open/short circuit of EGR.
- Judge NG when ECM output level is different from actual terminal level.

#### 2. COMPONENT DESCRIPTION

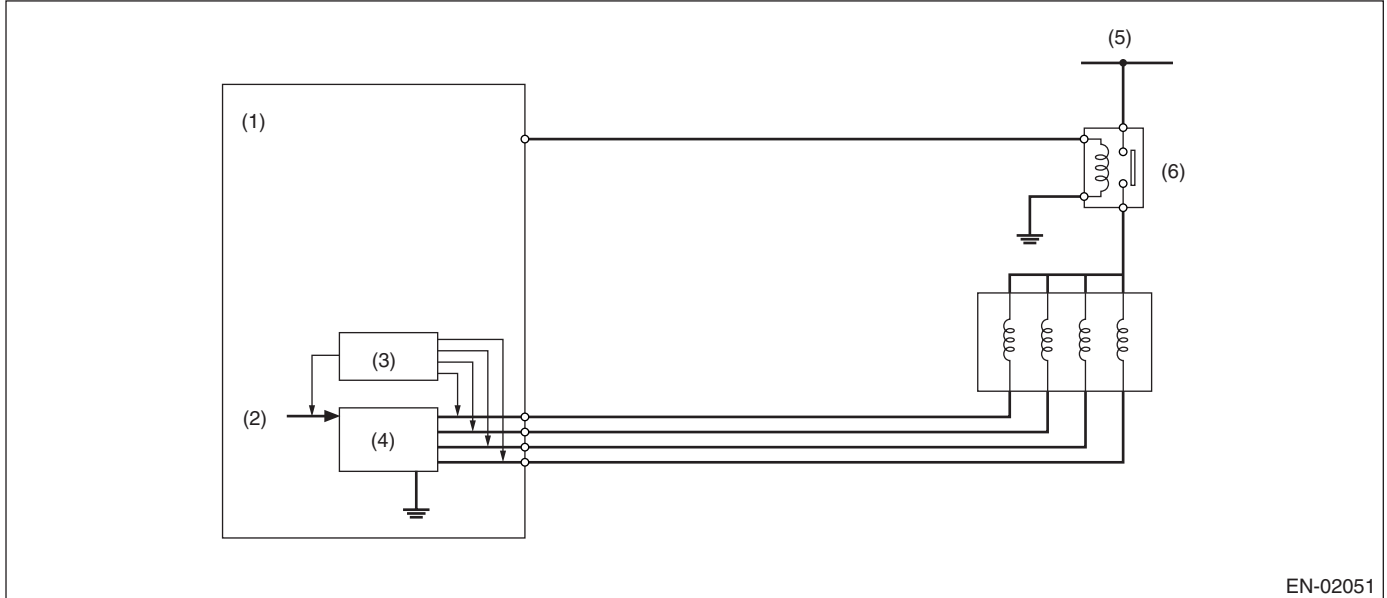

EN-02051

- |                                 |                       |                     |
|---------------------------------|-----------------------|---------------------|
| (1) Engine Control Module (ECM) | (3) Detecting circuit | (5) Battery voltage |
| (2) CPU                         | (4) Switching circuit | (6) Main relay      |

#### 3. ENABLE CONDITION

Secondary Parameters	Enable Conditions
Target position of EGR valve	> 0 step
Battery voltage	> 10.9 V

#### 4. GENERAL DRIVING CYCLE

Perform the diagnosis continuously when EGR operating.

#### 5. DIAGNOSTIC METHOD

##### • Abnormality Judgment

Judge NG when the continuous time until completing the malfunction criteria below becomes more than 2.5 seconds.

Malfunction Criteria	Threshold Value
Terminal voltage level when ECM outputs OFF signal	Low level

**Time Needed for Diagnosis:** 2.5 seconds

**Malfunction Indicator Light Illumination:** Illuminates as soon as malfunction occurs.

# Diagnostic Trouble Code (DTC) Detecting Criteria

GENERAL DESCRIPTION

## • Normality Judgment

Judge OK and clear the NG when the malfunction criteria below are not completed.

### Judgment Value

Malfunction Criteria	Threshold Value
Terminal voltage level when ECM outputs ON signal	High level

## 6. DTC CLEAR CONDITION

- When the OK idling cycle was completed 40 times in a row
- When "Clear Memory" was performed

## 7. MALFUNCTION INDICATOR LIGHT CLEAR CONDITION

- When the OK driving cycle was completed 3 times in a row
- When "Clear Memory" was performed

## 8. FAIL SAFE

- Front oxygen (A/F) sensor main learning compensation: Not allowed to calculate
- Knock sensor learning compensation: Not allowed to calculate
- EGR control: Not allowed to operate

## 9. ECM OPERATION AT DTC SETTING

Memorize the freeze frame data. (For test mode \$02)

# Diagnostic Trouble Code (DTC) Detecting Criteria

## GENERAL DESCRIPTION

### CV:DTC P1493 EGR SOLENOID VALVE SIGNAL #1 CIRCUIT MALFUNCTION (HIGH INPUT)

#### 1. OUTLINE OF DIAGNOSIS

- Detect the open/short circuit of EGR.
- Judge NG when ECM output level is different from actual terminal level.

#### 2. COMPONENT DESCRIPTION

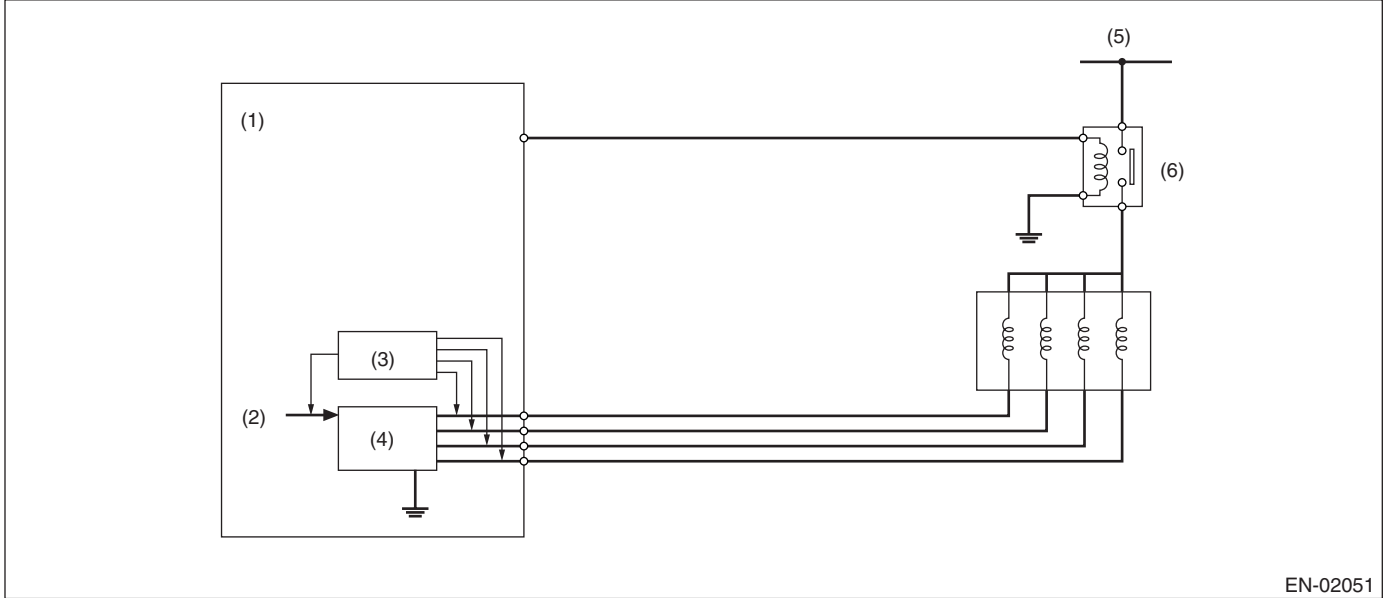

EN-02051

- |                                 |                       |                     |
|---------------------------------|-----------------------|---------------------|
| (1) Engine Control Module (ECM) | (3) Detecting circuit | (5) Battery voltage |
| (2) CPU                         | (4) Switching circuit | (6) Main relay      |

#### 3. ENABLE CONDITION

Secondary Parameters	Enable Conditions
Battery voltage	> 10.9 V
EGR valve target position	> 0 step

#### 4. GENERAL DRIVING CYCLE

Always perform the diagnosis continuously.

#### 5. DIAGNOSTIC METHOD

##### • Abnormality Judgment

Judge NG when the continuous time until completing the malfunction criteria below becomes more than 2.5 seconds.

Malfunction Criteria	Threshold Value
Terminal voltage level when ECM outputs ON signal	High level

**Time Needed for Diagnosis:** 2.5 seconds

**Malfunction Indicator Light Illumination:** Illuminates as soon as malfunction occurs.

# Diagnostic Trouble Code (DTC) Detecting Criteria

GENERAL DESCRIPTION

## • Normality Judgment

Judge OK and clear the NG when the malfunction criteria below are not completed.

### Judgment Value

Malfunction Criteria	Threshold Value
Terminal voltage level when ECM outputs OFF signal	Low level

## 6. DTC CLEAR CONDITION

- When the OK idling cycle is completed 40 times in a row
- When "Clear Memory" was performed

## 7. MALFUNCTION INDICATOR LIGHT CLEAR CONDITION

- When the OK driving cycle was completed 3 times in a row
- When "Clear Memory" was performed

## 8. FAIL SAFE

- Front oxygen (A/F) sensor main learning compensation: Not allowed to calculate
- Knock sensor learning compensation: Not allowed to calculate
- EGR control: Not allowed to operate

## 9. ECM OPERATION AT DTC SETTING

Memorize the freeze frame data. (For test mode \$02)

### **CW:DTC P1494 EGR SOLENOID VALVE SIGNAL #2 CIRCUIT MALFUNCTION (LOW INPUT)**

NOTE:

For the detecting criteria, refer to DTC P1492. <Ref. to GD(H4SO)-172, DTC P1492 EGR SOLENOID VALVE SIGNAL #1 CIRCUIT MALFUNCTION (LOW INPUT), Diagnostic Trouble Code (DTC) Detecting Criteria.>

### **CX:DTC P1495 EGR SOLENOID VALVE SIGNAL #2 CIRCUIT MALFUNCTION (HIGH INPUT)**

NOTE:

For the detecting criteria, refer to DTC P1493. <Ref. to GD(H4SO)-174, DTC P1493 EGR SOLENOID VALVE SIGNAL #1 CIRCUIT MALFUNCTION (HIGH INPUT), Diagnostic Trouble Code (DTC) Detecting Criteria.>

### **CY:DTC P1496 EGR SOLENOID VALVE SIGNAL #3 CIRCUIT MALFUNCTION (LOW INPUT)**

NOTE:

For the detecting criteria, refer to DTC P1492. <Ref. to GD(H4SO)-172, DTC P1492 EGR SOLENOID VALVE SIGNAL #1 CIRCUIT MALFUNCTION (LOW INPUT), Diagnostic Trouble Code (DTC) Detecting Criteria.>

### **CZ:DTC P1497 EGR SOLENOID VALVE SIGNAL #3 CIRCUIT MALFUNCTION (HIGH INPUT)**

NOTE:

For the detecting criteria, refer to DTC P1493. <Ref. to GD(H4SO)-174, DTC P1493 EGR SOLENOID VALVE SIGNAL #1 CIRCUIT MALFUNCTION (HIGH INPUT), Diagnostic Trouble Code (DTC) Detecting Criteria.>

# Diagnostic Trouble Code (DTC) Detecting Criteria

## GENERAL DESCRIPTION

### DA:DTC P1498 EGR SOLENOID VALVE SIGNAL #4 CIRCUIT MALFUNCTION (LOW INPUT)

#### NOTE:

For the detecting criteria, refer to DTC P1492. <Ref. to GD(H4SO)-172, DTC P1492 EGR SOLENOID VALVE SIGNAL #1 CIRCUIT MALFUNCTION (LOW INPUT), Diagnostic Trouble Code (DTC) Detecting Criteria.>

### DB:DTC P1499 EGR SOLENOID VALVE SIGNAL #4 CIRCUIT MALFUNCTION (HIGH INPUT)

#### NOTE:

For the detecting criteria, refer to DTC P1493. <Ref. to GD(H4SO)-174, DTC P1493 EGR SOLENOID VALVE SIGNAL #1 CIRCUIT MALFUNCTION (HIGH INPUT), Diagnostic Trouble Code (DTC) Detecting Criteria.>

### DC:DTC P1518 STARTER SWITCH CIRCUIT LOW INPUT

#### 1. OUTLINE OF DIAGNOSIS

Detect the open or short circuit of starter SW.

Judge OFF NG when it turns to “after engine starting” while the starter has never been set to ON.

#### 2. ENABLE CONDITION

Secondary Parameters	Enable Conditions
None	

#### 3. GENERAL DRIVING CYCLE

Always perform the diagnosis continuously.

#### 4. DIAGNOSTIC METHOD

##### • Abnormality Judgment

Judge OFF NG when the malfunction criteria below are completed.

##### Judgment Value

Malfunction Criteria	Threshold Value
Vehicle speed	< 1 km/h (0.62 MPH)
Starter ON signal	Not detected
Engine speed after the engine speed of less than 500 rpm continues 0.8 seconds or more	≥ 500 rpm

**Time Needed for Diagnosis:** 1 second

**Malfunction Indicator Light Illumination:** Illuminates when malfunction occurs in 2 continuous driving cycles.

##### • Normality Judgment

Judge OFF OK and clear the NG when the malfunction criteria below are completed.

##### Judgment Value

Malfunction Criteria	Threshold Value
Starter ON	Experienced
Battery voltage	> 8 V

#### 5. DTC CLEAR CONDITION

- When the OK idling cycle was completed 40 times in a row
- When “Clear Memory” was performed



# Diagnostic Trouble Code (DTC) Detecting Criteria

GENERAL DESCRIPTION

## 6. MALFUNCTION INDICATOR LIGHT CLEAR CONDITION

- When the OK driving cycle was completed 3 times in a row
- When "Clear Memory" was performed

## 7. FAIL SAFE

None

## 8. ECM OPERATION AT DTC SETTING

Memorize the freeze frame data. (For test mode \$02)

## DD:DTC P1560 BACK-UP VOLTAGE CIRCUIT MALFUNCTION

### 1. OUTLINE OF DIAGNOSIS

Detect open or short circuit of the back-up voltage circuit.

Judge NG when the back-up voltage becomes smaller than the battery voltage.

### 2. ENABLE CONDITION

Secondary Parameter	Enable Condition
None	

### 3. GENERAL DRIVING CYCLE

Always perform the diagnosis continuously.

### 4. DIAGNOSTIC METHOD

#### • Abnormality Judgment

Judge NG when the continuous time of completing the malfunction criteria below becomes more than 2.5 seconds.

#### Judgment Value

Malfunction Criteria	Threshold Value
Voltage of back-up power	Low
Battery voltage	$\geq 10.9$ V
Engine speed	$\geq 500$ rpm

**Time Needed for Diagnosis:** 2.5 seconds

**Malfunction Indicator Light Illumination:** Illuminates as soon as malfunction occurs.

#### • Normality Judgment

Judge OK and clear NG when the malfunction criteria below is completed.

#### Judgment Value

Malfunction Criteria	Threshold Value
Voltage of back-up power supply	High
Battery voltage	$\geq 10.9$ V
Engine speed	$\geq 500$ rpm

## 5. DTC CLEAR CONDITION

- When the OK idling cycle was completed 40 times in a row
- When "Clear Memory" was performed

## 6. MALFUNCTION INDICATOR LIGHT CLEAR CONDITION

- When the OK driving cycle was completed 3 times in a row
- When "Clear Memory" was performed

## 7. FAIL SAFE

None

# Diagnostic Trouble Code (DTC) Detecting Criteria

## GENERAL DESCRIPTION

---

### 8. ECM OPERATION AT DTC SETTING

Memorize the freeze frame data. (For test mode \$02)

#### **DE:DTC P1570 ANTENNA**

##### 1. OUTLINE OF DIAGNOSIS

For the detecting criteria, refer to DTC P0513. <Ref. to GD(H4SO)-144, DTC P0513 INCORRECT IMMOBILIZER KEY, Diagnostic Trouble Code (DTC) Detecting Criteria.>

#### **DF:DTC P1571 REFERENCE CODE INCOMPATIBILITY**

##### 1. OUTLINE OF DIAGNOSIS

For the detecting criteria, refer to DTC P0513. <Ref. to GD(H4SO)-144, DTC P0513 INCORRECT IMMOBILIZER KEY, Diagnostic Trouble Code (DTC) Detecting Criteria.>

#### **DG:DTC P1572 IMM CIRCUIT FAILURE (EXCEPT ANTENNA CIRCUIT)**

##### 1. OUTLINE OF DIAGNOSIS

For the detecting criteria, refer to DTC P0513. <Ref. to GD(H4SO)-144, DTC P0513 INCORRECT IMMOBILIZER KEY, Diagnostic Trouble Code (DTC) Detecting Criteria.>

#### **DH:DTC P1574 KEY COMMUNICATION FAILURE**

##### 1. OUTLINE OF DIAGNOSIS

For the detecting criteria, refer to DTC P0513. <Ref. to GD(H4SO)-144, DTC P0513 INCORRECT IMMOBILIZER KEY, Diagnostic Trouble Code (DTC) Detecting Criteria.>

#### **DI: DTC P1576 EGI CONTROL MODULE EEPROM**

##### 1. OUTLINE OF DIAGNOSIS

For the detecting criteria, refer to DTC P0513. <Ref. to GD(H4SO)-144, DTC P0513 INCORRECT IMMOBILIZER KEY, Diagnostic Trouble Code (DTC) Detecting Criteria.>

#### **DJ:DTC P1577 IMM CONTROL MODULE EEPROM**

##### 1. OUTLINE OF DIAGNOSIS

For the detecting criteria, refer to DTC P0513. <Ref. to GD(H4SO)-144, DTC P0513 INCORRECT IMMOBILIZER KEY, Diagnostic Trouble Code (DTC) Detecting Criteria.>

# Diagnostic Trouble Code (DTC) Detecting Criteria

GENERAL DESCRIPTION

## DK:DTC P2096 POST CATALYST FUEL TRIM SYSTEM TOO LEAN BANK 1

### 1. OUTLINE OF DIAGNOSIS

Detect the malfunction of fuel system from the amount of sub feedback control.

Judge NG when the sub feedback learning value sticks to lean sides during sub feedback learning control.

### 2. COMPONENT DESCRIPTION

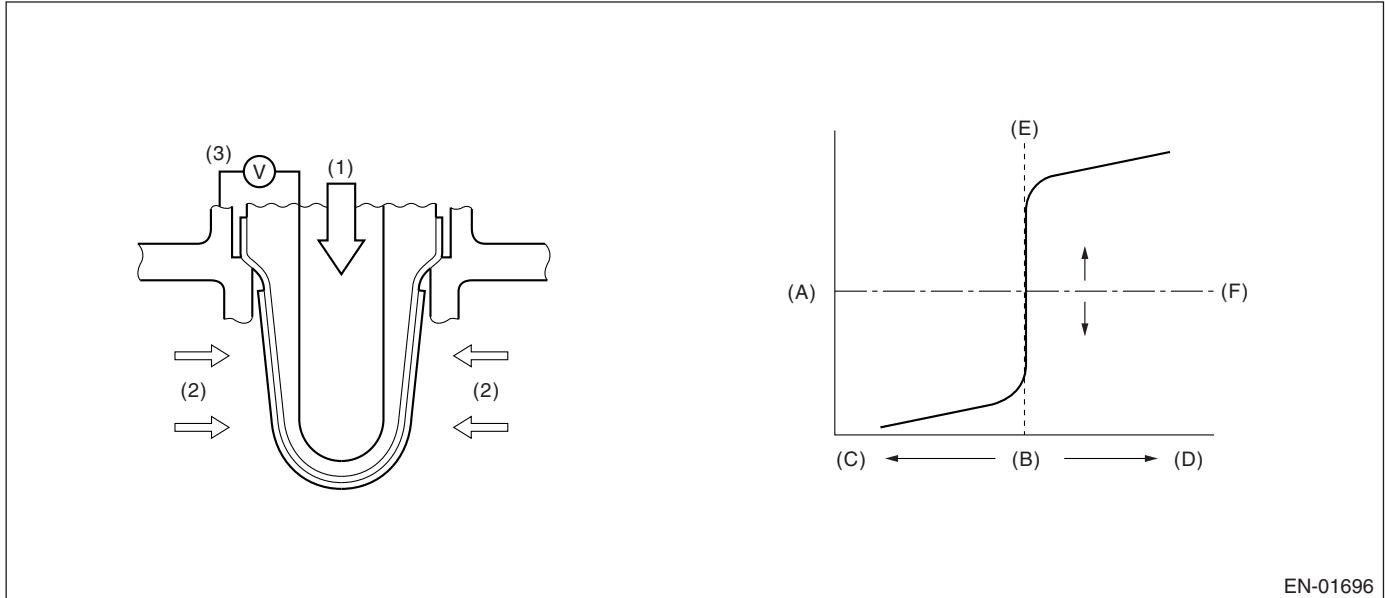

EN-01696

- (1) Atmosphere
- (2) Exhaust gas
- (3) Electromotive force

- (A) Electromotive force
- (B) Air fuel ratio
- (C) Rich

- (D) Lean
- (E) Theoretical air fuel ratio
- (F) Comparative voltage

### 3. ENABLE CONDITION

Secondary Parameters	Enable Conditions
Continuous time of completing condition below	1 second or more
Sub feedback leaning enable condition	Complete

### 4. GENERAL DRIVING CYCLE

Perform the diagnosis continuously at a constant speed of 50 to 100 km/h (31 to 62 MPH).

### 5. DIAGNOSTIC METHOD

Judge NG when the continuous time of completing the malfunction criteria below becomes more than 5 seconds. Judge OK when it becomes less than 5 seconds.

#### Judgment Value

Malfunction Criteria	Threshold Value
Sub feedback learning value	$\leq -0.02$

**Time Needed for Diagnosis:** 5 seconds  $\times$  1 time

**Malfunction Indicator Light Illumination:** Illuminates when malfunction occurs in 2 continuous driving cycles.

### 6. DTC CLEAR CONDITION

- When the OK idling cycle was completed 40 times in a row
- When "Clear Memory" was performed

# Diagnostic Trouble Code (DTC) Detecting Criteria

## GENERAL DESCRIPTION

### 7. MALFUNCTION INDICATOR LIGHT CLEAR CONDITION

- When OK with similar drive in 3 drive cycles
- When “Clear Memory” was performed

### 8. FAIL SAFE

None

### 9. ECM OPERATION AT DTC SETTING

Memorize the freeze frame data. (For test mode \$02)

## DL:DTC P2097 POST CATALYST FUEL TRIM SYSTEM TOO RICH BANK 1

### 1. OUTLINE OF DIAGNOSIS

Detect the malfunction of fuel system from the amount of sub feedback control.

Judge NG when the sub feedback learning value sticks to rich sides during sub feedback learning control.

### 2. COMPONENT DESCRIPTION

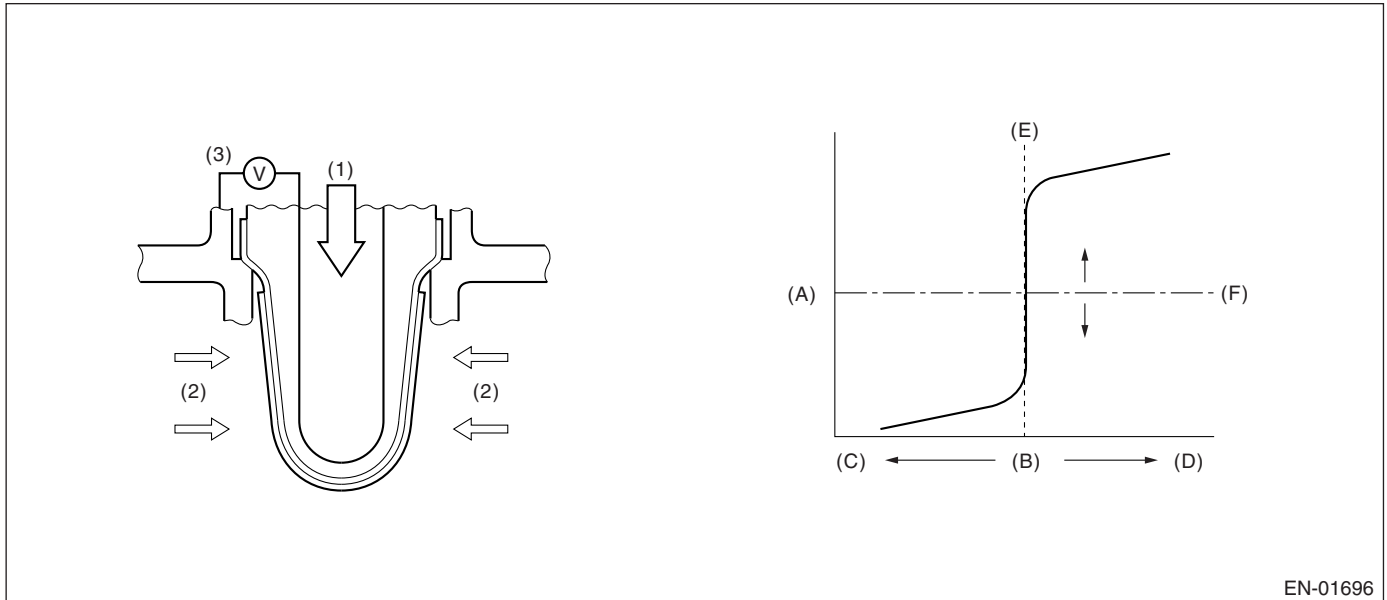

EN-01696

- (1) Atmosphere
- (2) Exhaust gas
- (3) Electromotive force

- (A) Electromotive force
- (B) Air fuel ratio
- (C) Rich

- (D) Lean
- (E) Theoretical air fuel ratio
- (F) Comparative voltage

### 3. ENABLE CONDITION

Secondary Parameters	Enable Conditions
Continuous time of completing condition below	1 second or more
Sub feedback leaning enable condition	Complete

### 4. GENERAL DRIVING CYCLE

Perform the diagnosis continuously at a constant speed 50 to 100 km/h (31 to 62 MPH).

# Diagnostic Trouble Code (DTC) Detecting Criteria

GENERAL DESCRIPTION

## 5. DIAGNOSTIC METHOD

Judge NG when the continuous time of completing the malfunction criteria below becomes more than 5 seconds. Judge OK when it becomes less than 5 seconds.

### Judgment Value

Malfunction Criteria	Threshold Value
Sub feedback learning value	$\geq 0.038$

**Time Needed for Diagnosis:** 5 seconds  $\times$  1 time

**Malfunction Indicator Light Illumination:** Illuminates when malfunction occurs in 2 continuous drive cycles.

## 6. DTC CLEAR CONDITION

- When the OK idling cycle was completed 40 times in a row
- When "Clear Memory" was performed

## 7. MALFUNCTION INDICATOR LIGHT CLEAR CONDITION

- When OK with similar drive in 3 drive cycles.
- When "Clear Memory" was performed

## 8. FAIL SAFE

None

## 9. ECM OPERATION AT DTC SETTING

Memorize the freeze frame data. (For test mode \$02)

# Diagnostic Trouble Code (DTC) Detecting Criteria

## GENERAL DESCRIPTION

### DM:DTC P2101 THROTTLE ACTUATOR CONTROL MOTOR CIRCUIT RANGE/ PERFORMANCE

#### 1. OUTLINE OF DIAGNOSIS

Judge NG when the motor current becomes large or drive circuit is heated.

#### 2. COMPONENT DESCRIPTION

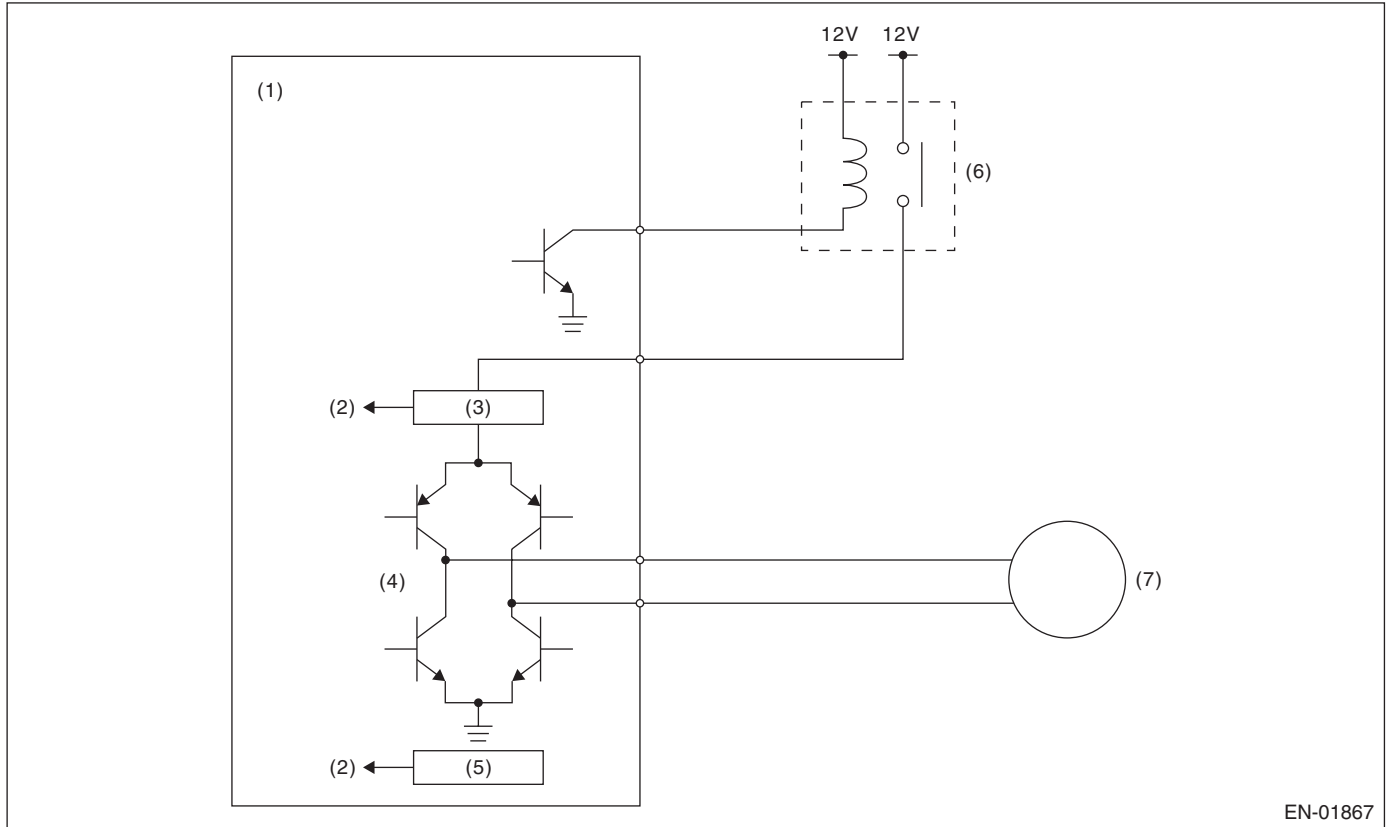

EN-01867

- |                                   |                                       |           |
|-----------------------------------|---------------------------------------|-----------|
| (1) Engine control unit (ECM)     | (4) Drive circuit                     | (7) Motor |
| (2) Detection circuit             | (5) Temperature detection circuit     |           |
| (3) Overcurrent detection circuit | (6) Electronic control throttle relay |           |

#### 3. ENABLE CONDITION

Secondary Parameters	Enable Conditions
Under control of electronic control throttle	ON

#### 4. GENERAL DRIVING CYCLE

Always perform the diagnosis continuously.

# Diagnostic Trouble Code (DTC) Detecting Criteria

GENERAL DESCRIPTION

## 5. DIAGNOSTIC METHOD

Judge OK and clear the NG when the malfunction criteria below are completed.

### Judgment Value

Malfunction Criteria	Threshold Value
Motor current	$\leq 8$ A
Drive circuit inner temperature	$\leq 175^{\circ}\text{C}$ (347°F)

### Time Needed for Diagnosis:

- 500 milliseconds (NG judgment)
- 2,000 milliseconds (OK judgment)

**Malfunction Indicator Light Illumination:** Illuminates as soon as malfunction occurs.

## 6. DTC CLEAR CONDITION

- When the OK idling cycle was completed 40 times in a row
- When "Clear Memory" was performed (Only with engine stopped)

## 7. MALFUNCTION INDICATOR LIGHT CLEAR CONDITION

- When the OK driving cycle was completed 3 times in a row
- When "Clear Memory" was performed (Only with engine stopped)

## 8. FAIL SAFE

Stop the continuity to the electronic control throttle motor. (Fix the throttle opening angle to 6°.)

## 9. ECM OPERATION AT DTC SETTING

Memorize the freeze frame data. (For test mode \$02)

# Diagnostic Trouble Code (DTC) Detecting Criteria

## GENERAL DESCRIPTION

### DN:DTC P2102 THROTTLE ACTUATOR CONTROL MOTOR CIRCUIT LOW

#### 1. OUTLINE OF DIAGNOSIS

Judge NG when the electronic control throttle power is not supplied even when ECM sets the electronic throttle control relay to ON.

#### 2. COMPONENT DESCRIPTION

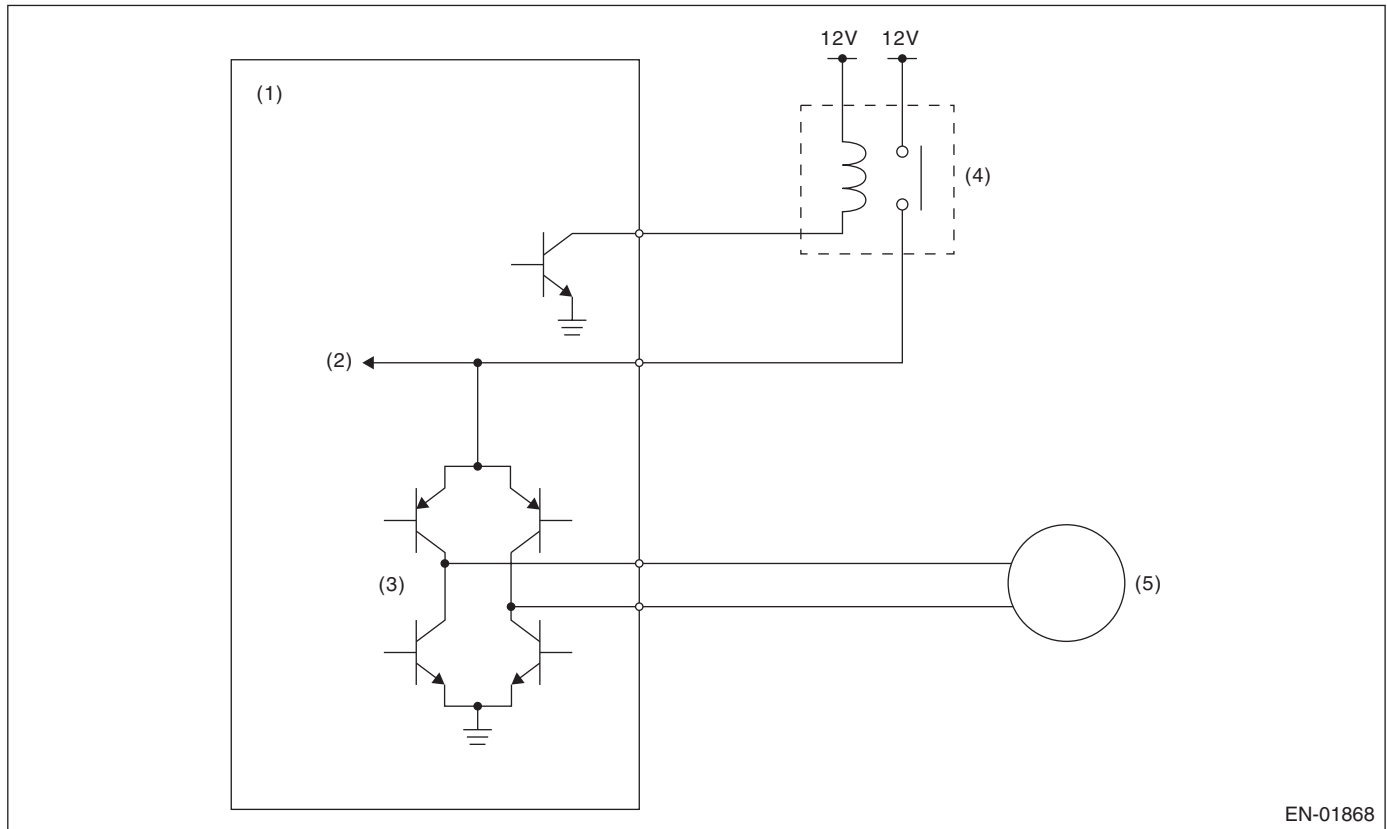

EN-01868

(1) Engine control module (ECM)

(3) Drive circuit

(5) Motor

(2) Voltage detection circuit

(4) Electronic control throttle relay

#### 3. ENABLE CONDITION

Secondary Parameters	Enable Conditions
Electronic control throttle relay output	ON

#### 4. GENERAL DRIVING CYCLE

Always perform the diagnosis continuously.

#### 5. DIAGNOSTIC METHOD

Judge OK and clear the NG when the malfunction criteria below are completed.

##### Judgment Value

Malfunction Criteria	Threshold Value
Motor power voltage	$\geq 5 \text{ V}$

##### Time Needed for Diagnosis:

- 400 milliseconds (For NG)
- 2,000 milliseconds (For OK)

**Malfunction Indicator Light Illumination:** Illuminates as soon as malfunction occurs.



# Diagnostic Trouble Code (DTC) Detecting Criteria

GENERAL DESCRIPTION

## 6. DTC CLEAR CONDITION

- When the OK idling cycle was completed 40 times in a row
- When "Clear Memory" was performed (Only with engine stopped)

## 7. MALFUNCTION INDICATOR LIGHT CLEAR CONDITION

- When the OK driving cycle was completed 3 times in a row
- When "Clear Memory" was performed (Only with engine stopped)

## 8. FAIL SAFE

Stop the continuity to the electronic control throttle motor. (Fix the throttle opening angle to 6°.)

## 9. ECM OPERATION AT DTC SETTING

Memorize the freeze frame data. (For test mode \$02)

## DO:DTC P2103 THROTTLE ACTUATOR CONTROL MOTOR CIRCUIT HIGH

### 1. OUTLINE OF DIAGNOSIS

Judge NG when the electronic control throttle power is not supplied even when ECM sets the electronic throttle control relay to OFF.

### 2. COMPONENT DESCRIPTION

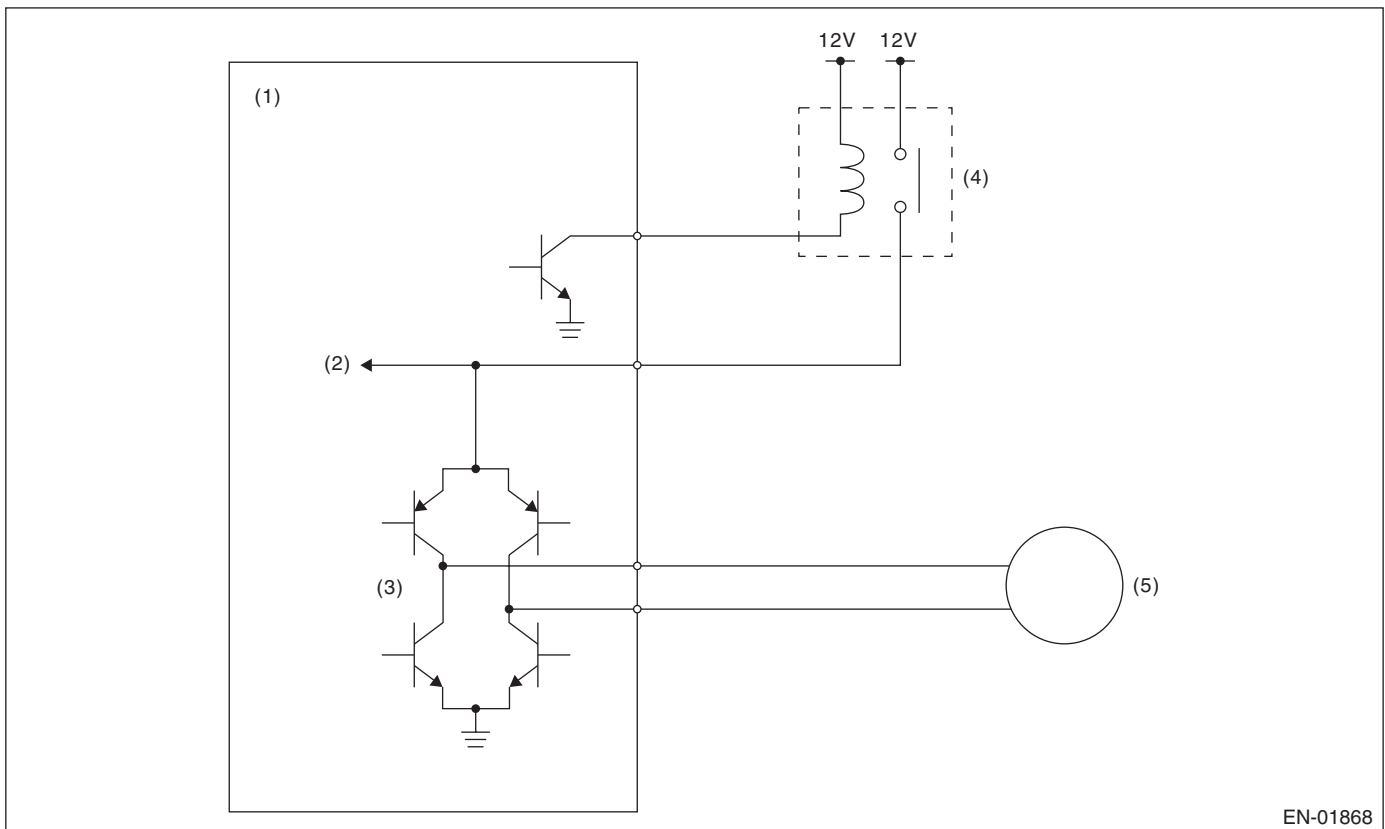

EN-01868

- |                                 |                                       |           |
|---------------------------------|---------------------------------------|-----------|
| (1) Engine control module (ECM) | (3) Drive circuit                     | (5) Motor |
| (2) Voltage detection circuit   | (4) Electronic control throttle relay |           |

### 3. ENABLE CONDITION

Secondary Parameters	Enable Conditions
Electronic control throttle relay output	OFF

# Diagnostic Trouble Code (DTC) Detecting Criteria

## GENERAL DESCRIPTION

---

### 4. GENERAL DRIVING CYCLE

- Ignition switch ON → OFF
- Ignition switch OFF → ON (After clear memory only)

### 5. DIAGNOSTIC METHOD

Judge OK and clear the NG when the malfunction criteria below are completed.

#### Judgment Value

Malfunction Criteria	Threshold Value
Motor power voltage	≤ 5 V

#### Time Needed for Diagnosis:

- 600 milliseconds (For NG)
- 400 milliseconds (For OK)

**Malfunction Indicator Light Illumination:** Illuminates as soon as malfunction occurs.

### 6. DTC CLEAR CONDITION

- When the OK idling cycle was completed 40 times in a row
- When “Clear Memory” was performed (Only with engine stopped)

### 7. MALFUNCTION INDICATOR LIGHT CLEAR CONDITION

- When the OK driving cycle was completed 3 times in a row
- When “Clear Memory” was performed (Only with engine stopped)

### 8. FAIL SAFE

Stop the continuity to the electronic control throttle motor. (Fix the throttle opening angle to 6°.)

### 9. ECM OPERATION AT DTC SETTING

Memorize the freeze frame data. (For test mode \$02)

# Diagnostic Trouble Code (DTC) Detecting Criteria

GENERAL DESCRIPTION

## DP:DTC P2109 THROTTLE ANGLE SENSOR CLOSED POSITION ERROR

### 1. OUTLINE OF DIAGNOSIS

Judge NG when all close point learning cannot conducted or abnormal value is detected.

### 2. COMPONENT DESCRIPTION

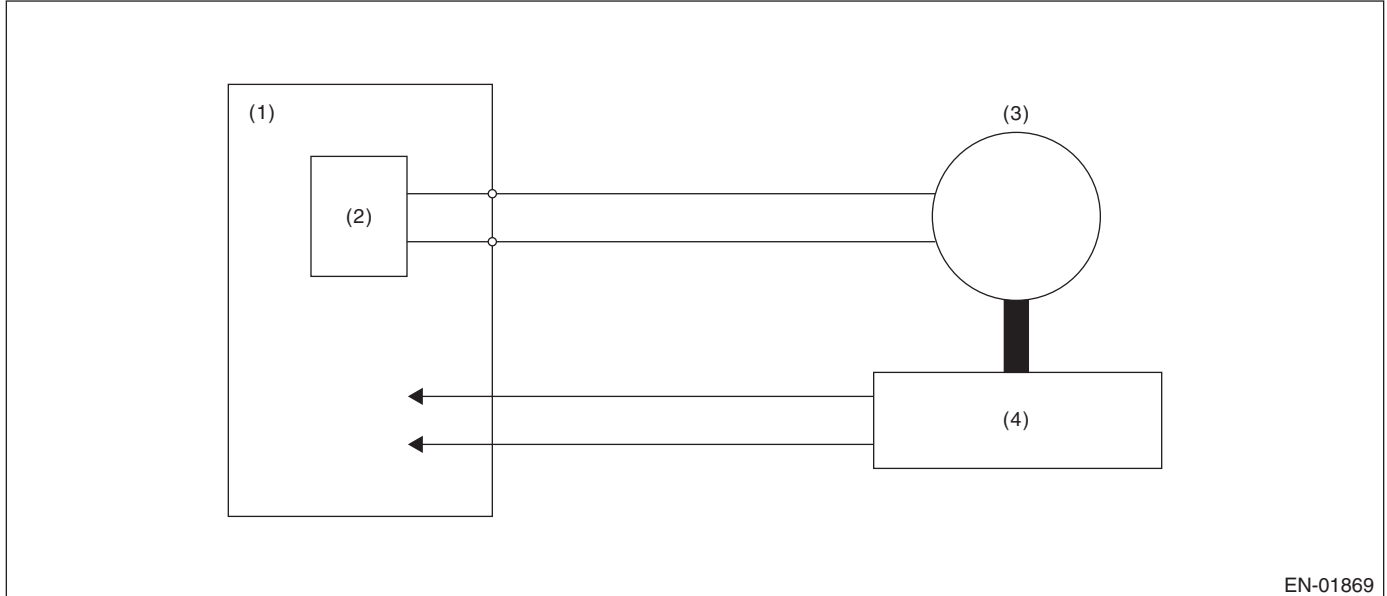

EN-01869

- (1) Engine control module (ECM)
- (2) Drive circuit
- (3) Motor
- (4) Throttle position sensor

### 3. ENABLE CONDITION

Secondary Parameters	Enable Conditions
Ignition switch	ON → OFF
Ignition switch (after clear memory only)	OFF → ON

### 4. GENERAL DRIVING CYCLE

Perform the diagnosis at all close point learning.

### 5. DIAGNOSTIC METHOD

#### • Abnormality Judgment

Judge OK and clear the NG when the malfunction criteria below are completed.

#### Judgment Value

Malfunction Criteria	Threshold Value
Throttle sensor opening angle at all close point learning	10.127° or more, 19.872° or less
Throttle opening angle when ignition switch ON – Throttle min. stop position	≥ 1.683°

**Time Needed for Diagnosis:** 8 — 80 milliseconds

**Malfunction Indicator Light Illumination:** Illuminates as soon as malfunction occurs.

### 6. DTC CLEAR CONDITION

- When the OK idling cycle was completed 40 times in a row
- When “Clear Memory” was performed (Only with engine stopped)

# Diagnostic Trouble Code (DTC) Detecting Criteria

## GENERAL DESCRIPTION

### 7. MALFUNCTION INDICATOR LIGHT CLEAR CONDITION

- When the OK driving cycle was completed 3 times in a row
- When “Clear Memory” was performed (Only with engine stopped)

### 8. FAIL SAFE

Stop the continuity to the electronic control throttle motor. (Fix the throttle opening angle to 6°.)

### 9. ECM OPERATION AT DTC SETTING

Memorize the freeze frame data. (For test mode \$02)

## DQ:DTC P2122 THROTTLE/PEDAL POSITION SENSOR/SWITCH “D” CIRCUIT LOW INPUT

### 1. OUTLINE OF DIAGNOSIS

Detect the open or short circuit of accelerator pedal position sensor 1.  
Judge NG when out of the standard value.

### 2. COMPONENT DESCRIPTION

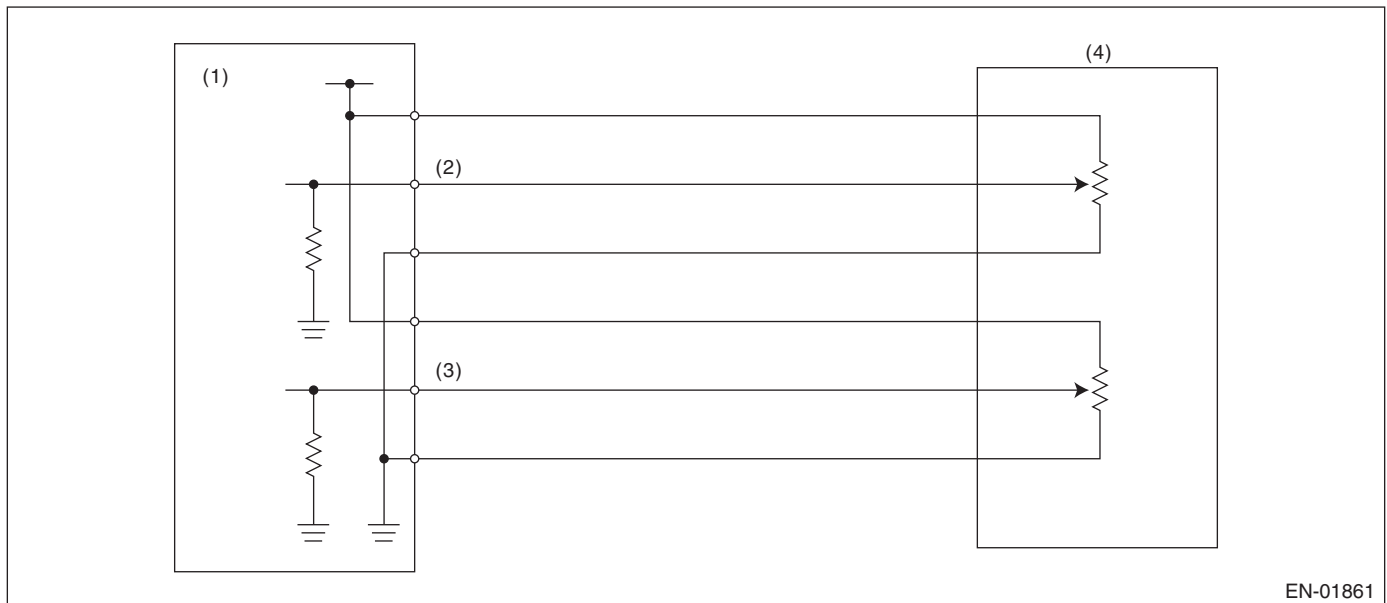

EN-01861

- |  |  |
|--|--|
| (1) Engine control module (ECM)                | (3) Accelerator pedal position sensor 2 signal |
| (2) Accelerator pedal position sensor 1 signal | (4) Accelerator pedal position sensor          |

### 3. ENABLE CONDITION

Secondary Parameters	Enable Conditions
Ignition switch	ON

### 4. GENERAL DRIVING CYCLE

Always perform the diagnosis continuously.

### 5. DIAGNOSTIC METHOD

Judge OK and clear the NG when the malfunction criteria below are completed.

#### Judgment Value

Malfunction Criteria	Threshold Value
Sensor 1 input voltage	$\geq 0.308$ V

# Diagnostic Trouble Code (DTC) Detecting Criteria

GENERAL DESCRIPTION

**Time Needed for Diagnosis:** 100 milliseconds

**Malfunction Indicator Light Illumination:** Illuminates as soon as malfunction occurs.

## 6. DTC CLEAR CONDITION

- When the OK idling cycle was completed 40 times in a row
- When "Clear Memory" was performed (Only with engine stopped)

## 7. MALFUNCTION INDICATOR LIGHT CLEAR CONDITION

- When the OK driving cycle was completed 3 times in a row
- When "Clear Memory" was performed (Only with engine stopped)

## 8. FAIL SAFE

- Single malfunction: Control with normal sensor
- Multi malfunction: Fix the throttle opening angle to 6°.

## 9. ECM OPERATION AT DTC SETTING

Memorize the freeze frame data. (For test mode \$02)

## DR:DTC P2123 THROTTLE/PEDAL POSITION SENSOR/SWITCH "D" CIRCUIT HIGH INPUT

### 1. OUTLINE OF DIAGNOSIS

Detect the open or short circuit of accelerator pedal position sensor 1.  
Judge NG when out of the standard value.

### 2. COMPONENT DESCRIPTION

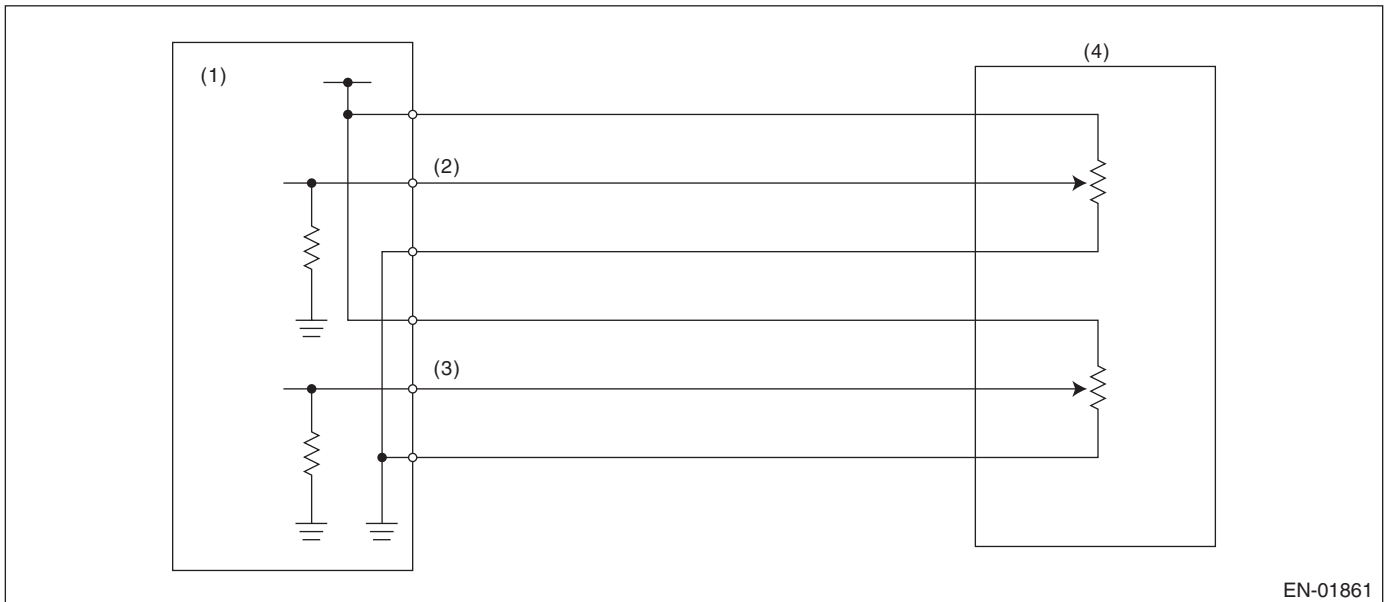

EN-01861

- |  |                                       |
|--|---------------------------------------|
| (1) Engine control module (ECM)                | (3) Accelerator pedal position sensor |
| (2) Accelerator pedal position sensor 1 signal | 2 signal                              |
|  | (4) Accelerator pedal position sensor |

### 3. ENABLE CONDITION

Secondary Parameters	Enable Conditions
Ignition switch	ON

# Diagnostic Trouble Code (DTC) Detecting Criteria

## GENERAL DESCRIPTION

---

### 4. GENERAL DRIVING CYCLE

Always perform the diagnosis continuously.

### 5. DIAGNOSTIC METHOD

Judge OK and clear the NG when the malfunction criteria below are completed.

#### Judgment Value

Malfunction Criteria	Threshold Value
Sensor 1 input voltage	$\leq 4.865$ V

**Time Needed for Diagnosis:** 100 milliseconds

**Malfunction Indicator Light Illumination:** Illuminates as soon as malfunction occurs.

### 6. DTC CLEAR CONDITION

- When the OK idling cycle was completed 40 times in a row
- When "Clear Memory" was performed (Only with engine stopped)

### 7. MALFUNCTION INDICATOR LIGHT CLEAR CONDITION

- When the OK driving cycle was completed 3 times in a row
- When "Clear Memory" was performed (Only with engine stopped)

### 8. FAIL SAFE

- Single malfunction: Control with normal sensor
- Multi malfunction: Fix the throttle opening angle to 6°.

### 9. ECM OPERATION AT DTC SETTING

Memorize the freeze frame data. (For test mode \$02)

## DS:DTC P2127 THROTTLE/PEDAL POSITION SENSOR/SWITCH “E” CIRCUIT LOW INPUT

### 1. OUTLINE OF DIAGNOSIS

Detect the open or short circuit of accelerator pedal position sensor 2.  
Judge NG when out of the standard value.

### 2. COMPONENT DESCRIPTION

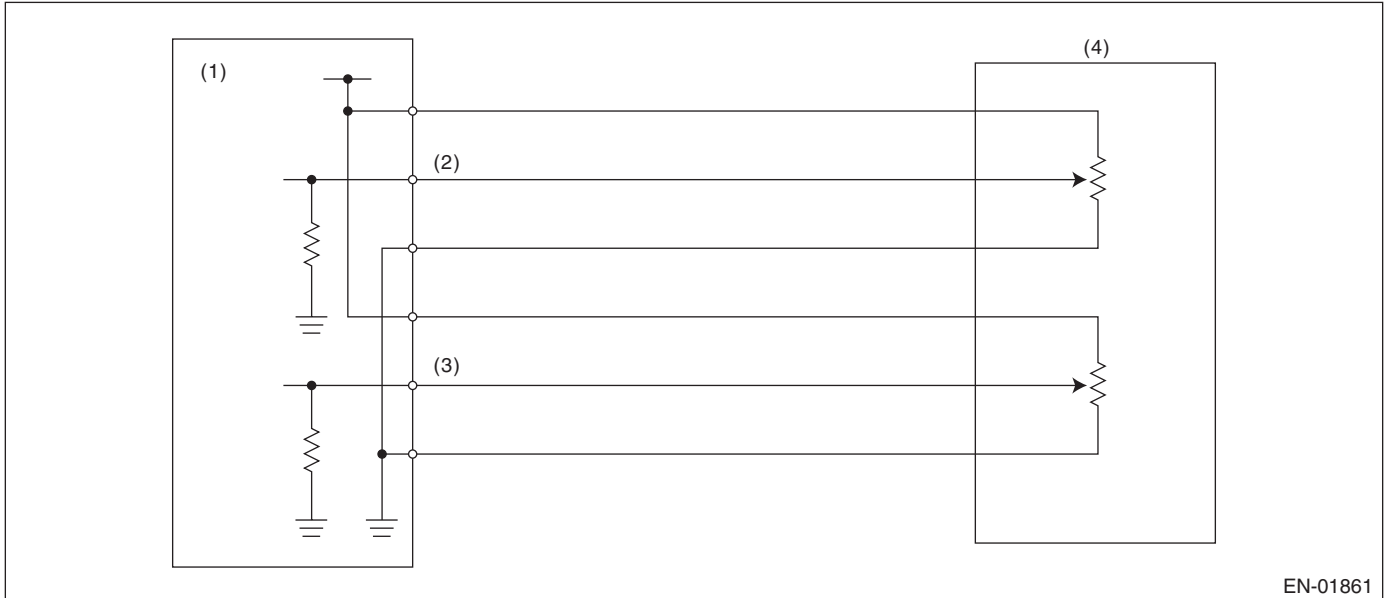

EN-01861

- |  |  |
|--|--|
| (1) Engine control module (ECM)                | (3) Accelerator pedal position sensor 2 signal |
| (2) Accelerator pedal position sensor 1 signal | (4) Accelerator pedal position sensor          |

### 3. ENABLE CONDITION

Secondary Parameters	Enable Conditions
Ignition switch	ON

### 4. GENERAL DRIVING CYCLE

Always perform the diagnosis continuously.

### 5. DIAGNOSTIC METHOD

Judge OK and clear the NG when the malfunction criteria below are completed.

#### Judgment Value

Malfunction Criteria	Threshold Value
Sensor 2 input voltage	$\geq 0.308$ V

**Time Needed for Diagnosis:** 100 milliseconds

**Malfunction Indicator Light Illumination:** Illuminates as soon as malfunction occurs.

### 6. DTC CLEAR CONDITION

- When the OK idling cycle was completed 40 times in a row
- When “Clear Memory” was performed (Only with engine stopped)

### 7. MALFUNCTION INDICATOR LIGHT CLEAR CONDITION

- When the OK driving cycle was completed 3 times in a row
- When “Clear Memory” was performed (Only with engine stopped)

# Diagnostic Trouble Code (DTC) Detecting Criteria

## GENERAL DESCRIPTION

### 8. FAIL SAFE

- Single malfunction: Control with normal sensor
- Multi malfunction: Fix the throttle opening angle to 6°.

### 9. ECM OPERATION AT DTC SETTING

Memorize the freeze frame data. (For test mode \$02)

## DT:DTC P2128 THROTTLE/PEDAL POSITION SENSOR/SWITCH “E” CIRCUIT HIGH INPUT

### 1. OUTLINE OF DIAGNOSIS

Detect the open or short circuit of accelerator pedal position sensor 2.  
Judge NG when out of the standard value.

### 2. COMPONENT DESCRIPTION

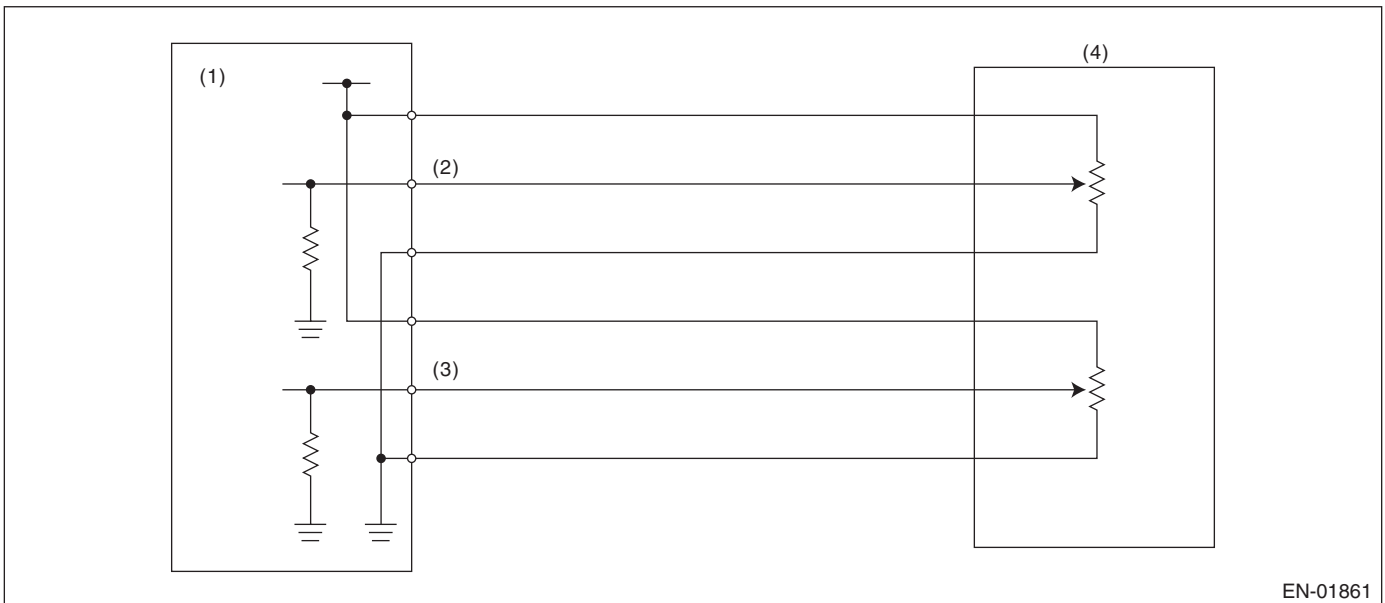

EN-01861

- |  |  |
|--|--|
| (1) Engine control module (ECM)                | (3) Accelerator pedal position sensor 2 signal |
| (2) Accelerator pedal position sensor 1 signal | (4) Accelerator pedal position sensor          |

### 3. ENABLE CONDITION

Secondary Parameters	Enable Conditions
Ignition switch	ON

### 4. GENERAL DRIVING CYCLE

Always perform the diagnosis continuously.

### 5. DIAGNOSTIC METHOD

Judge OK and clear the NG when the malfunction criteria below are completed.

#### Judgment Value

Malfunction Criteria	Threshold Value
Sensor 2 input voltage	≤ 4.865 V

**Time Needed for Diagnosis:** 100 milliseconds

**Malfunction Indicator Light Illumination:** Illuminates as soon as malfunction occurs.



# Diagnostic Trouble Code (DTC) Detecting Criteria

GENERAL DESCRIPTION

## 6. DTC CLEAR CONDITION

- When the OK idling cycle was completed 40 times in a row
- When “Clear Memory” was performed (Only with engine stopped)

## 7. MALFUNCTION INDICATOR LIGHT CLEAR CONDITION

- When the OK driving cycle was completed 3 times in a row
- When “Clear Memory” was performed (Only with engine stopped)

## 8. FAIL SAFE

- Single malfunction: Control with normal sensor
- Multi malfunction: Fix the throttle opening angle to 6°.

## 9. ECM OPERATION AT DTC SETTING

Memorize the freeze frame data. (For test mode \$02)

## DU:DTC P2135 THROTTLE/PEDAL POSITION SENSOR/SWITCH “A” / “B” VOLTAGE RATIONALITY

### 1. OUTLINE OF DIAGNOSIS

Judge NG when the signal level of throttle position sensor 1 is different from the throttle position sensor 2.

### 2. COMPONENT DESCRIPTION

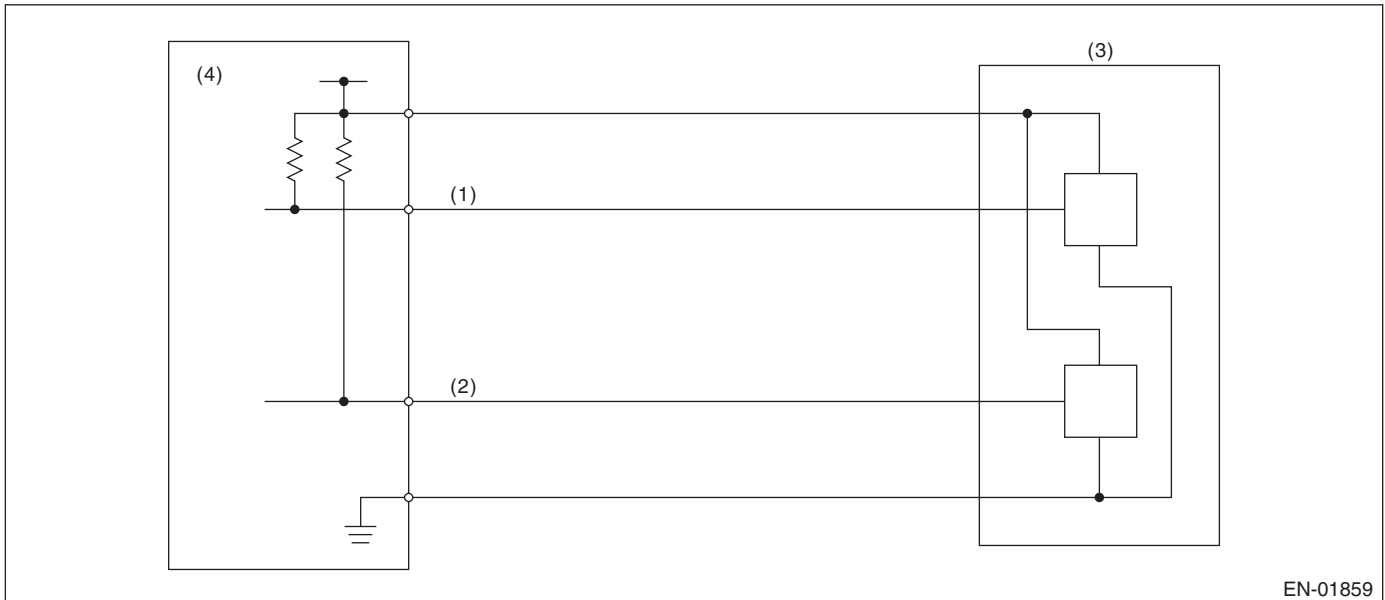

EN-01859

- |                                       |                                 |
|---------------------------------------|---------------------------------|
| (1) Throttle position sensor 1 signal | (3) Throttle position sensor    |
| (2) Throttle position sensor 2 signal | (4) Engine control module (ECM) |

### 3. ENABLE CONDITION

Secondary Parameters	Enable Conditions
Ignition switch	ON

### 4. GENERAL DRIVING CYCLE

Always perform the diagnosis continuously.

# Diagnostic Trouble Code (DTC) Detecting Criteria

## GENERAL DESCRIPTION

### 5. DIAGNOSTIC METHOD

Judge OK and clear the NG when the malfunction criteria below are completed.

#### Judgment Value

Malfunction Criteria	Threshold Value
Signal difference between two sensors	$\leq 4.5^\circ$

#### Details of Judgment Value

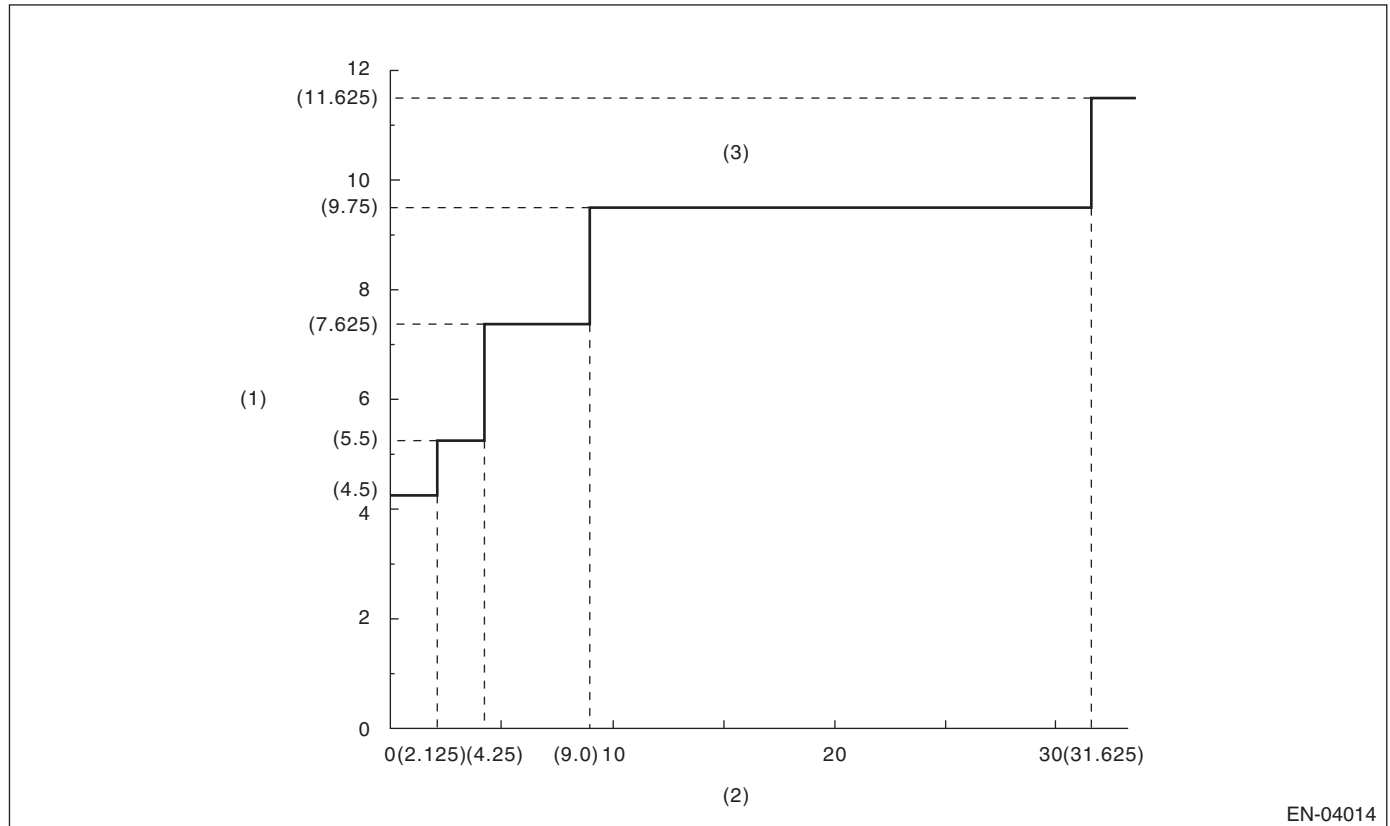

(1) Sensor output difference ( $^\circ$ )

(2) Throttle position sensor 1 opening angle ( $^\circ$ )

(3) NG area

**Time Needed for Diagnosis:** 24 milliseconds (NG judgment), 24 milliseconds (OK judgment)

**Malfunction Indicator Light Illumination:** Illuminates as soon as malfunction occurs.

### 6. DTC CLEAR CONDITION

- When the OK idling cycle was completed 40 times in a row
- When "Clear Memory" was performed (Only with engine stopped)

### 7. MALFUNCTION INDICATOR LIGHT CLEAR CONDITION

- When the OK driving cycle was completed 3 times in a row
- When "Clear Memory" was performed (Only with engine stopped)

### 8. FAIL SAFE

Stop the continuity to electronic control throttle motor. (Fix the throttle opening angle to  $6^\circ$ .)

### 9. ECM OPERATION AT DTC SETTING

Memorize the freeze frame data. (For test mode \$02)

## DV:DTC P2138 THROTTLE/PEDAL POSITION SENSOR/SWITCH “D” / “E” VOLTAGE RATIONALITY

### 1. OUTLINE OF DIAGNOSIS

Judge NG when the signal level of throttle position sensor 1 is different from the throttle position sensor 2.

### 2. COMPONENT DESCRIPTION

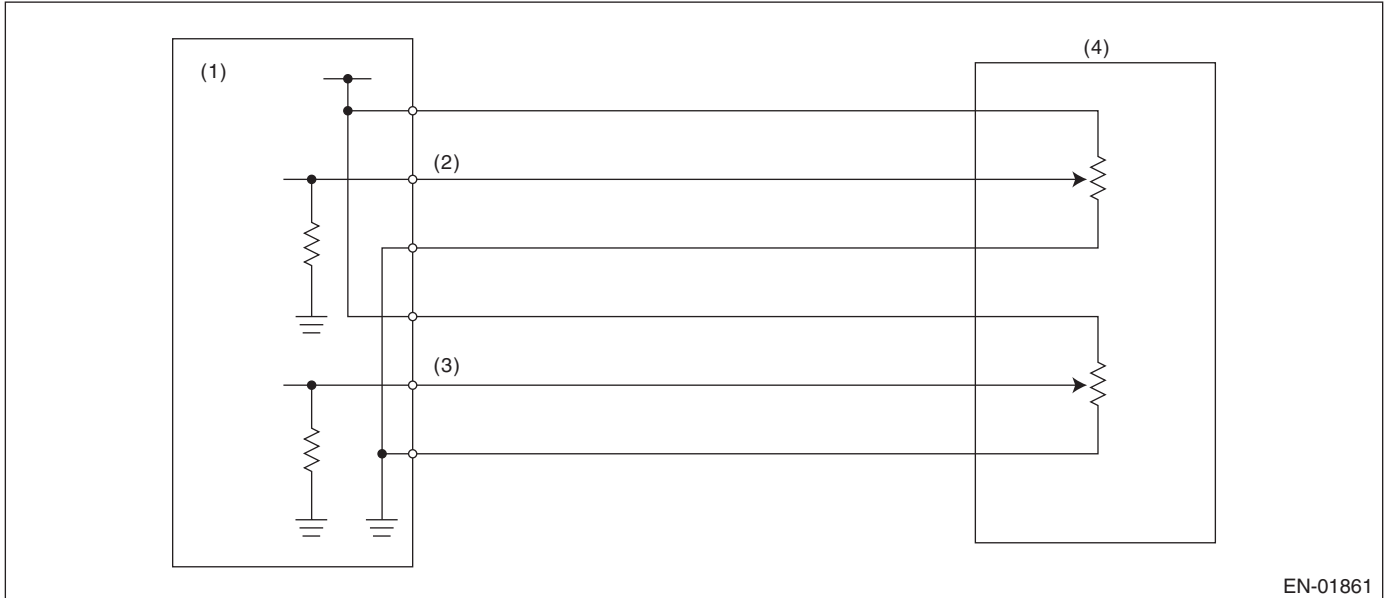

- |  |  |
|--|--|
| (1) Engine control module (ECM)                | (3) Accelerator pedal position sensor 2 signal |
| (2) Accelerator pedal position sensor 1 signal | (4) Accelerator pedal position sensor          |

### 3. ENABLE CONDITION

Secondary Parameters	Enable Conditions
Ignition switch	ON
Battery voltage	$\geq 6\text{ V}$

### 4. GENERAL DRIVING CYCLE

Always perform the diagnosis continuously.

### 5. DIAGNOSTIC METHOD

Judge OK and clear the NG when the malfunction criteria below are completed.

#### Judgment Value

Malfunction Criteria	Threshold Value
Signal difference between two sensors	$\leq 1.465^\circ$

# Diagnostic Trouble Code (DTC) Detecting Criteria

## GENERAL DESCRIPTION

### Details of Judgment Value

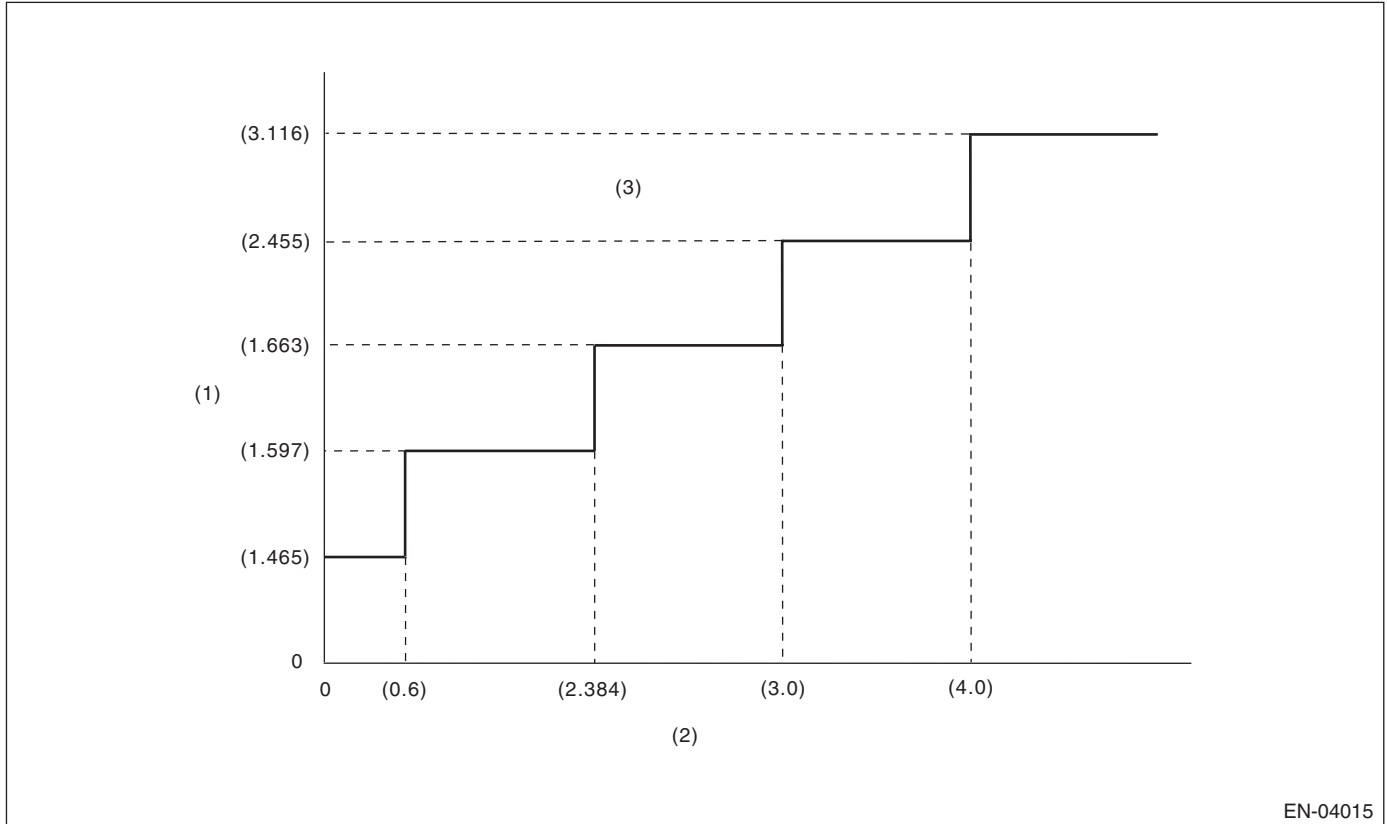

EN-04015

(1) Sensor output difference (°)

(2) Accelerator pedal position sensor

(3) NG area

2 opening angle (°)

### Time Needed for Diagnosis:

- 116 milliseconds (For NG)
- 1,000 milliseconds (For OK)

**Malfunction Indicator Light Illumination:** Illuminates as soon as malfunction occurs.

### 6. DTC CLEAR CONDITION

- When the OK idling cycle was completed 40 times in a row
- When "Clear Memory" was performed

### 7. MALFUNCTION INDICATOR LIGHT CLEAR CONDITION

- When the OK driving cycle was completed 3 times in a row
- When "Clear Memory" was performed

### 8. FAIL SAFE

Fix the throttle opening angle to 6°.

### 9. ECM OPERATION AT DTC SETTING

Memorize the freeze frame data. (For test mode \$02)

# Diagnostic Trouble Code (DTC) Detecting Criteria

GENERAL DESCRIPTION

## DW:DTC P2227 BAROMETRIC PRESSURE TOO LOW

### 1. OUTLINE OF DIAGNOSIS

Detect the malfunction of atmospheric pressure sensor output property. Judge NG when the atmospheric pressure sensor output is largely different from the intake manifold pressure at engine starting.

### 2. COMPONENT DESCRIPTION

Atmospheric pressure sensor is built in ECM.

### 3. ENABLE CONDITION

Secondary Parameters	Enable Conditions
Engine speed	< 300 rpm
Vehicle speed	< 1 km/h (0.62 MPH)

### 4. GENERAL DRIVING CYCLE

Perform the diagnosis before engine starting with the ignition switch ON.

### 5. DIAGNOSTIC METHOD

#### • Abnormality Judgment

Judge NG when the continuous time of completing the malfunction criteria below becomes more than 0.3 seconds.

#### Judgment Value

Malfunction Criteria	Threshold Value
Atmospheric – manifold absolute pressure	≥ 26.7 kPa (200 mmHg, 7.88 inHg)
Intake manifold pressure at engine starting – manifold absolute pressure	< 1.33 kPa (10 mmHg, 0.39 inHg)

**Time Needed for Diagnosis:**0.3 seconds

**Malfunction Indicator Light Illumination:**Detect when malfunction occurs in 2 continuous driving cycles.

#### • Normality Judgment

Judge OK and clear the NG when the continuous time of completing the malfunction criteria below becomes more than 0.3 seconds.

#### Judgment Value

Malfunction Criteria	Threshold Value
Atmospheric – manifold absolute pressure	< 26.7 kPa (200 mmHg, 7.88 inHg)

### 6. DTC CLEAR CONDITION n

- When the OK idling cycle was completed 40 times in a row
- When “Clear Memory” was performed

### 7. MALFUNCTION INDICATOR LIGHT CLEAR CONDITION

- When the OK driving cycle was completed 3 times in a row
- When “Clear Memory” was performed

### 8. FAIL SAFE

Atmospheric pressure sensor process: Fix the atmospheric pressure to 101 kPa (760 mmHg, 29.8 inHg).

### 9. ECM OPERATION AT DTC SETTING

Memorize the freeze frame data. (For test mode \$02)

# Diagnostic Trouble Code (DTC) Detecting Criteria

## GENERAL DESCRIPTION

### DX:DTC P2228 ATMOSPHERIC PRESSURE SENSOR CIRCUIT MALFUNCTION (LOW INPUT)

#### 1. OUTLINE OF DIAGNOSIS

Detect the open or short circuit of atmospheric pressure sensor.  
Judge NG when out of the standard value.

#### 2. COMPONENT DESCRIPTION

Atmospheric pressure sensor is built in ECM.

#### 3. ENABLE CONDITION

Secondary Parameters	Enable Conditions
None	

#### 4. GENERAL DRIVING CYCLE

Always perform the diagnosis continuously.

#### 5. DIAGNOSTIC METHOD

##### • Abnormality Judgment

Judge NG when the continuous time of completing the malfunction criteria below becomes more than 0.5 seconds.

##### Judgment Value

Malfunction Criteria	Threshold Value
Ignition switch	ON
Output voltage	< 0.118 V

**Time Needed for Diagnosis:** 0.5 seconds

**Malfunction Indicator Light Illumination:** Illuminates as soon as malfunction occurs.

##### • Normality Judgment

Judge OK and clear the NG when the malfunction criteria below are completed.

##### Judgment Value

Malfunction Criteria	Threshold Value
Ignition switch	ON
Output voltage	≥ 0.118 V

#### 6. DTC CLEAR CONDITION

- When the OK idling cycle was completed 40 times in a row
- When "Clear Memory" was performed

#### 7. MALFUNCTION INDICATOR LIGHT CLEAR CONDITION

- When the OK driving cycle was completed 3 times in a row
- When "Clear Memory" was performed

#### 8. FAIL SAFE

Atmospheric pressure sensor process: Fix the atmospheric pressure to 101 kPa (760 mmHg, 29.8 inHg).

#### 9. ECM OPERATION AT DTC SETTING

Memorize the freeze frame data. (For test mode \$02)

# Diagnostic Trouble Code (DTC) Detecting Criteria

GENERAL DESCRIPTION

## DY:DTC P2229 ATMOSPHERIC PRESSURE SENSOR CIRCUIT MALFUNCTION (HIGH INPUT)

### 1. OUTLINE OF DIAGNOSIS

Detect the open or short circuit of atmospheric pressure sensor.  
Judge NG when out of the standard value.

### 2. COMPONENT DESCRIPTION

Atmospheric pressure sensor is built in ECM.

### 3. ENABLE CONDITION

Secondary Parameters	Enable Conditions
None	

### 4. GENERAL DRIVING CYCLE

Always perform the diagnosis continuously.

### 5. DIAGNOSTIC METHOD

#### • Abnormality Judgment

Judge NG when the continuous time of completing the malfunction criteria below becomes more than 0.5 seconds.

#### Judgment Value

Malfunction Criteria	Threshold Value
Ignition switch	ON
Output voltage	$\geq 4.936$ V

**Time Needed for Diagnosis:** 0.5 seconds

**Malfunction Indicator Light Illumination:** Illuminates as soon as malfunction occurs.

#### • Normality Judgment

Judge OK and clear the NG when the malfunction criteria below are completed.

#### Judgment Value

Malfunction Criteria	Threshold Value
Ignition switch	ON
Output voltage	$< 4.936$ V

### 6. DTC CLEAR CONDITION

- When the OK idling cycle was completed 40 times in a row
- When "Clear Memory" was performed

### 7. MALFUNCTION INDICATOR LIGHT CLEAR CONDITION

- When the OK driving cycle was completed 3 times in a row
- When "Clear Memory" was performed

### 8. FAIL SAFE

Atmospheric pressure sensor process: Fix the atmospheric pressure to 101 kPa (760 mmHg, 29.8 inHg).

### 9. ECM OPERATION AT DTC SETTING

Memorize the freeze frame data. (For test mode \$02)

# Diagnostic Trouble Code (DTC) Detecting Criteria

GENERAL DESCRIPTION

---