

5. Wiring Diagram

A: POWER SUPPLY ROUTING

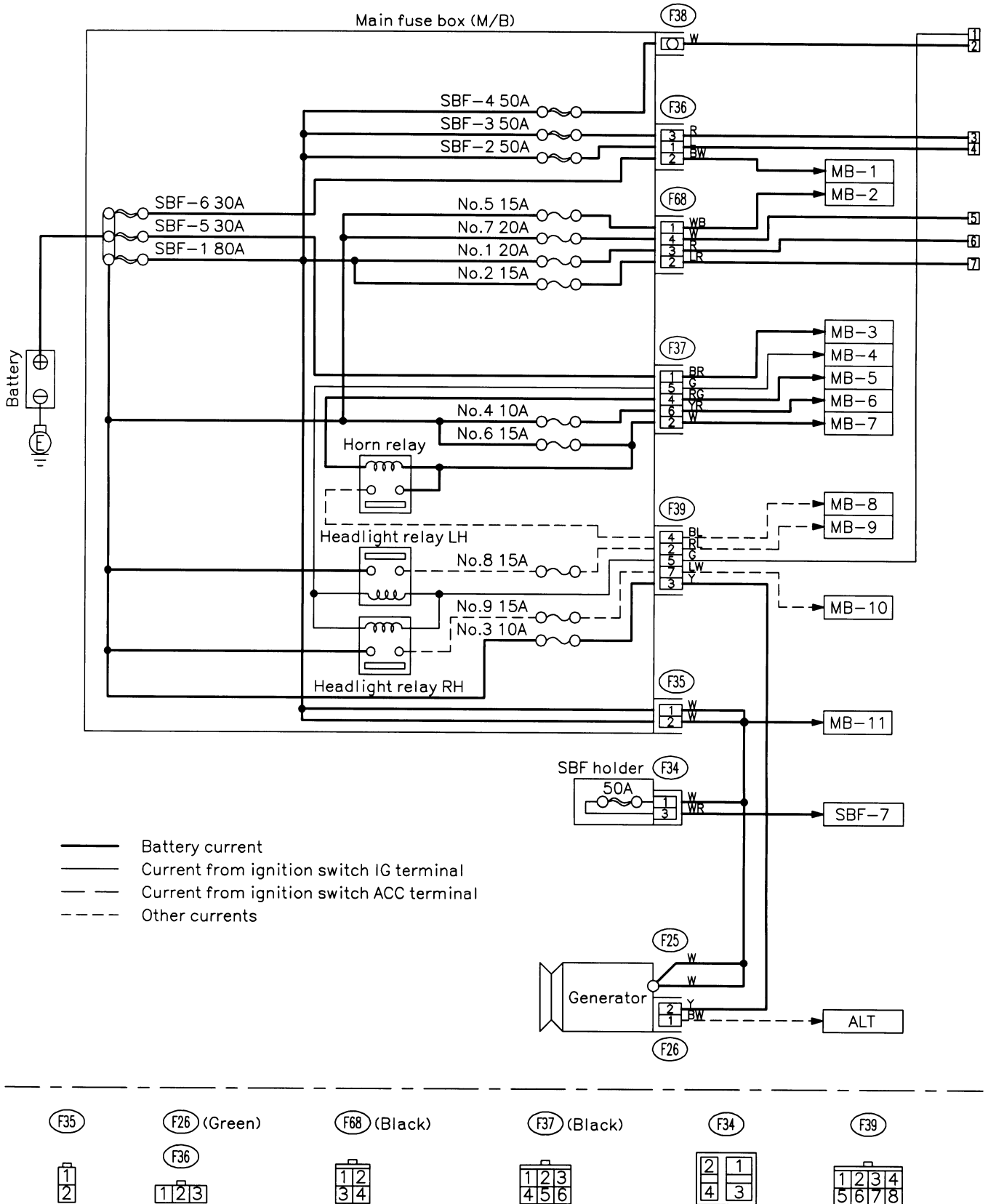

# WIRING DIAGRAM

[D5A0] **6-3**  
5. Wiring Diagram

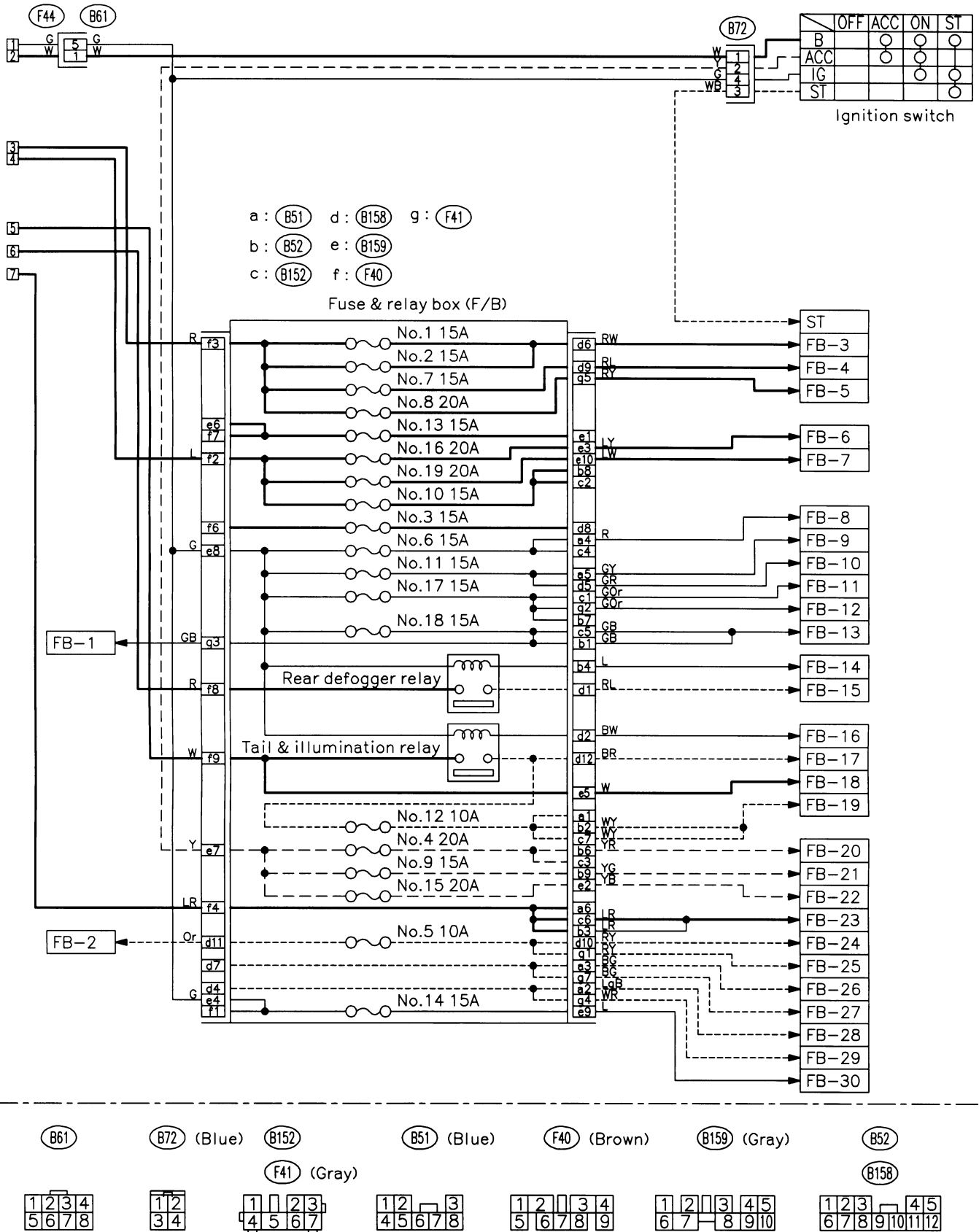

## 6-3 [D5A0]

### 5. Wiring Diagram

## WIRING DIAGRAM

No.	Load
MB-1	Power window and sunroof circuit breaker
MB-2	Door lock timer
MB-3	Data link connector Engine control module Fuel pump relay Main relay
MB-4	Daytime running light control module Diode (Daytime running light) Lighting switch
MB-5	Cruise control sub switch Horn switch
MB-6	Transmission control module
MB-7	AT shift lock control module Hazard switch Key warning switch
MB-8	Horn
MB-9	Headlight LH
MB-10	Combination meter Front fog light relay Front fog light switch Headlight RH
MB-11	A/C relay holder
SBF-7	ABS control module
ALT	Combination meter Daytime running light control module
ST	Engine control module (AT) Inhibitor switch (AT) Starter interlock relay (MT)
FB-1	Main fan relay
FB-2	Parking switch
FB-3	Blower motor relay
FB-4	Front fog light relay
FB-5	ABS control module
FB-6	Stop light switch
FB-7	Rear accessory power supply relay
FB-8	Airbag control module
FB-9	Airbag control module
FB-10	Engine control module Fuel pump relay Ignition coil Transmission control module
FB-11	Blower motor relay Mode control panel Rear defogger switch
FB-12	A/C relay Sub fan relay Thermal protector

No.	Load
FB-13	Back-up light switch (MT) Check connector Combination meter Daytime running light control module Daytime running light hi-beam relay Daytime running light relay Hazard switch Inhibitor switch (AT) Key warning module Power window and sunroof relay Vehicle speed sensor 2 (MT)
FB-14	Rear defogger switch
FB-15	Rear defogger Rear defogger switch
FB-16	Lighting switch
FB-17	Parking switch
FB-18	Parking switch
FB-19	Clock Illumination control module Illumination light
FB-20	AT shift lock control module Front accessory power supply Remote control rearview mirror switch Rear accessory power supply relay
FB-21	Radio
FB-22	Front washer motor Front wiper motor Front wiper & washer switch Rear washer motor Rear wiper motor Rear wiper relay
FB-23	Combination meter Radio Room light Spot light Trunk room light
FB-24	License plate light LH License plate light RH Tail light LH Tail light RH
FB-25	Front clearance light LH Front clearance light RH
FB-26	Combination meter Hazard switch Rear turn signal light LH Turn signal switch
FB-27	Front turn signal light LH Side turn signal light LH
FB-28	Combination meter Hazard switch Rear turn signal light RH Turn signal switch
FB-29	Front turn signal light RH Side turn signal light RH
FB-30	ABS control module AT shift lock control module Cruise control main switch Cruise control module

B: GROUND DISTRIBUTION

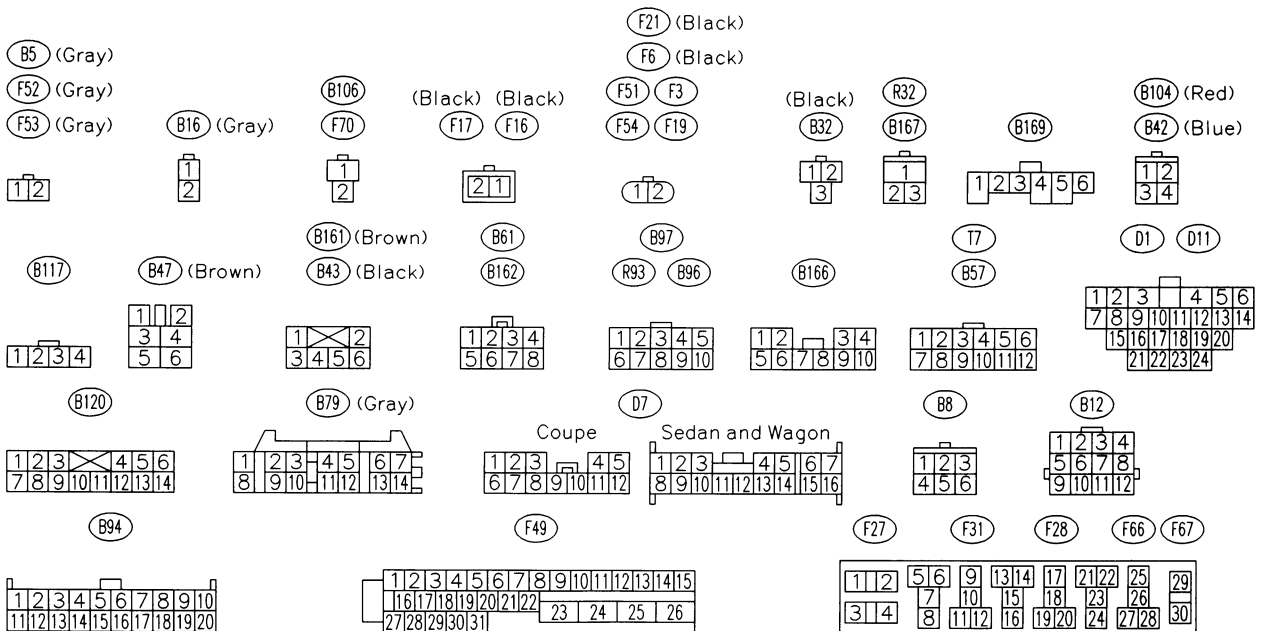
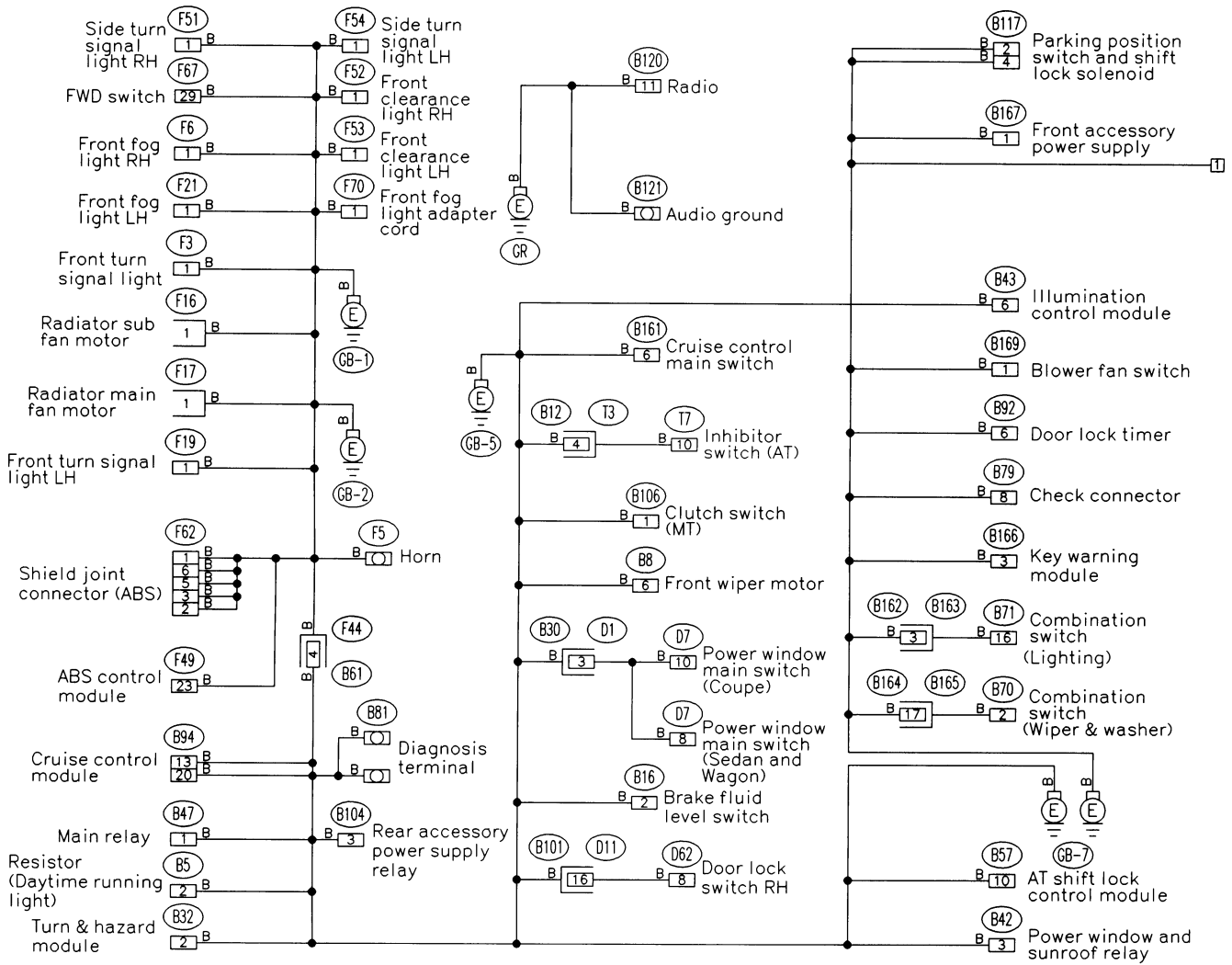

**6-3 [D5B0]**  
5. Wiring Diagram

**WIRING DIAGRAM**

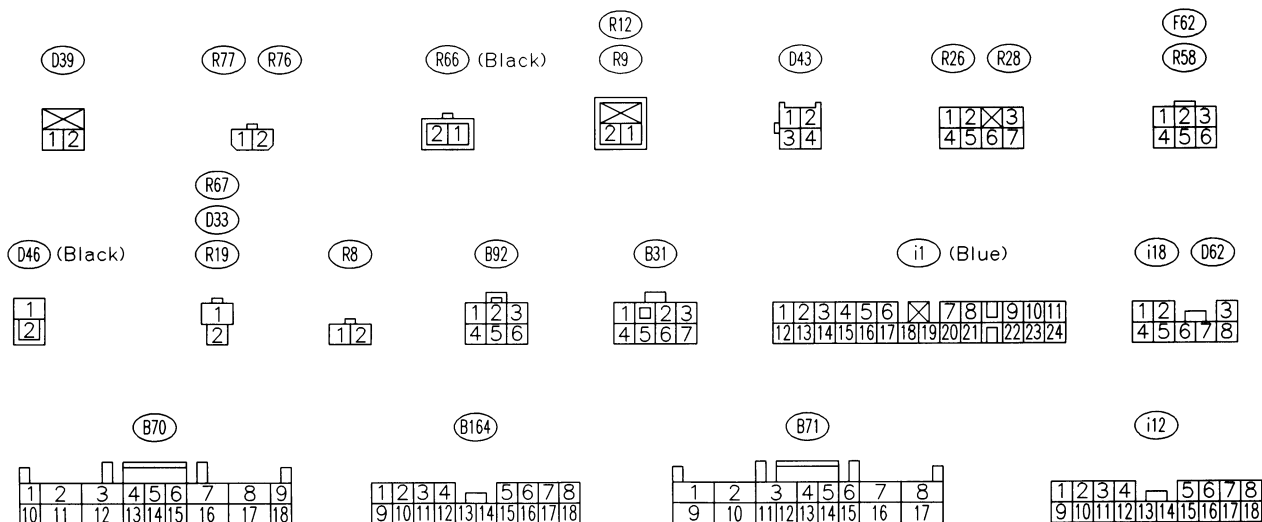
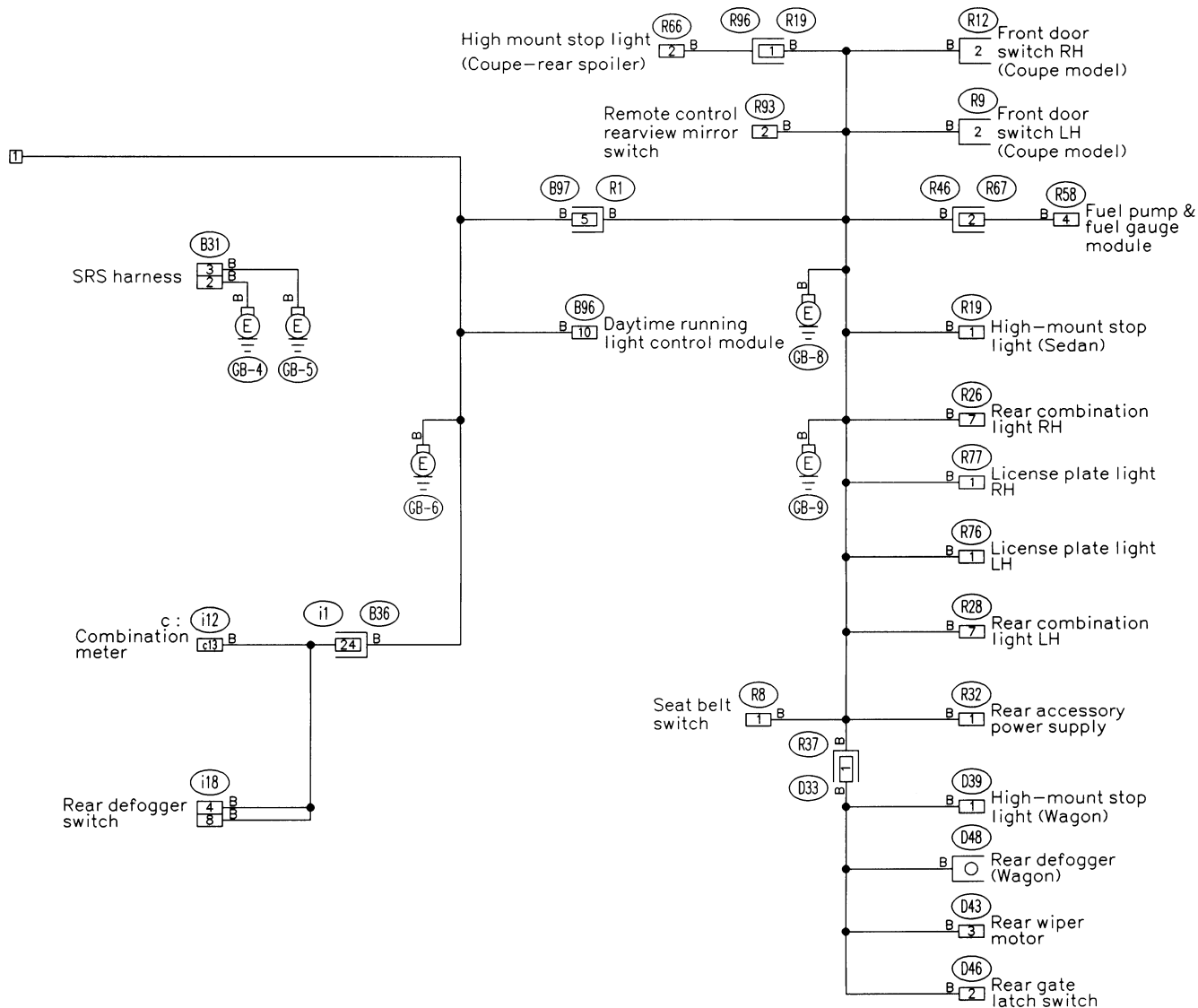

GU04-06B

# WIRING DIAGRAM

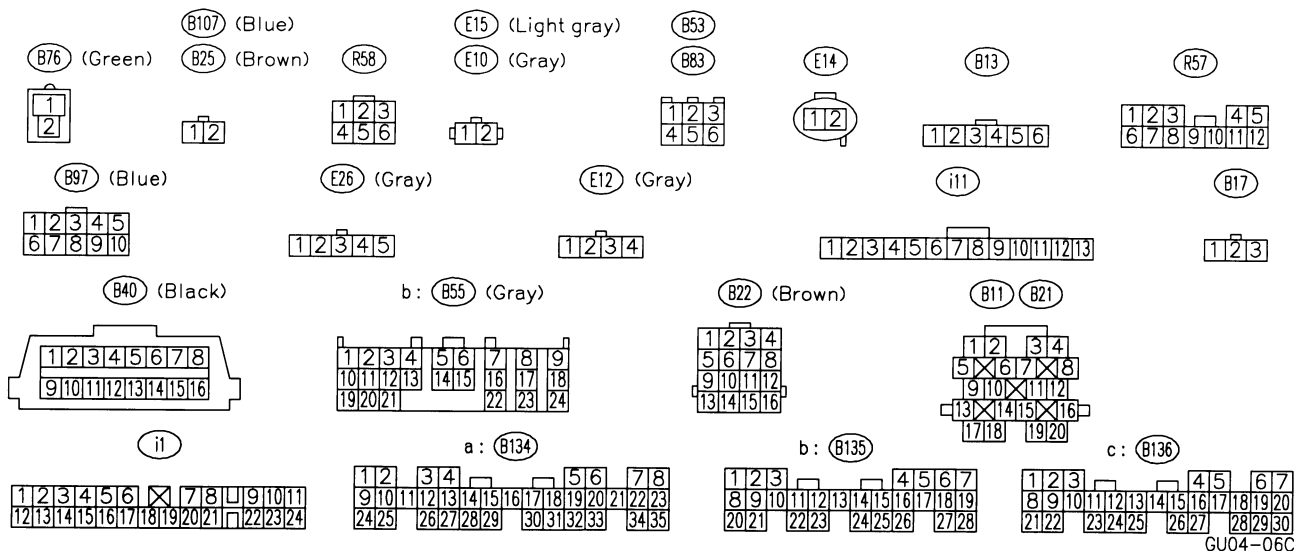
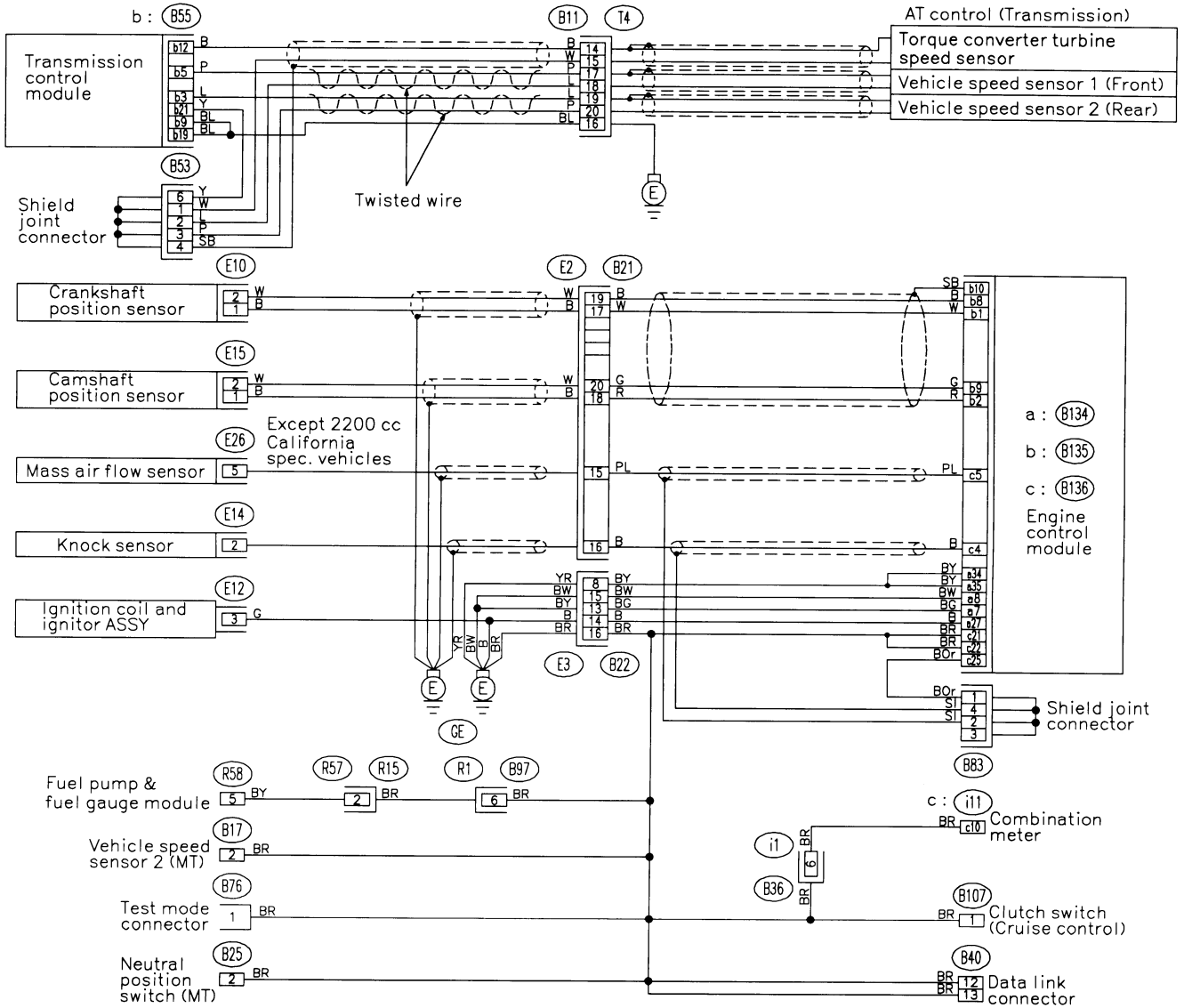

GU04-06C

C: AIRBAG SYSTEM

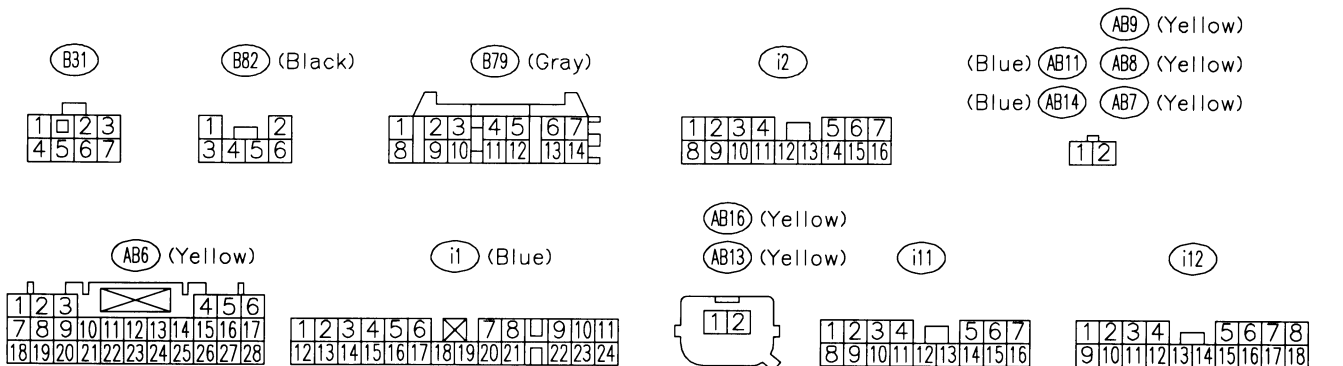
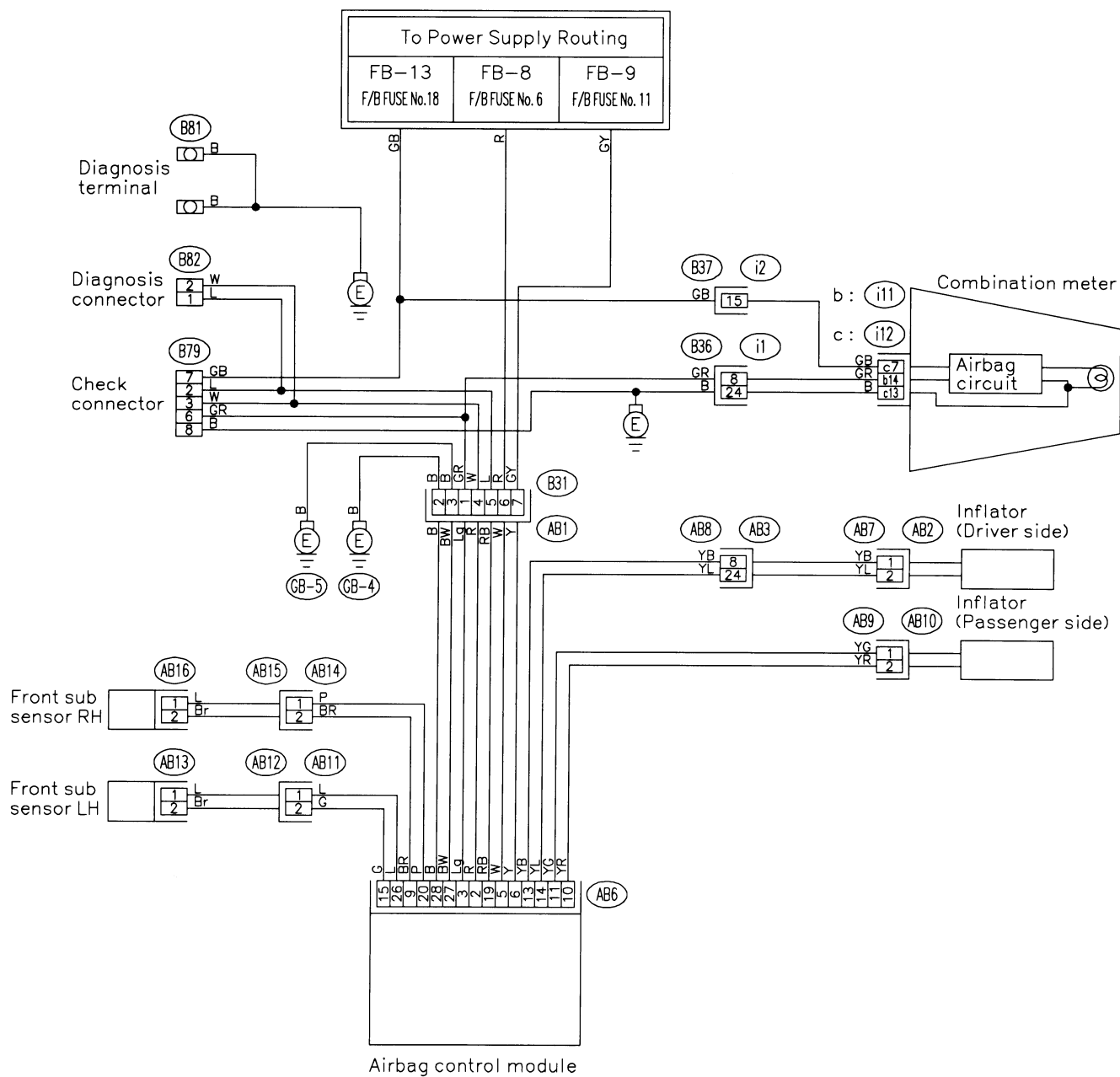

# WIRING DIAGRAM

## D: AIR CONDITIONING SYSTEM

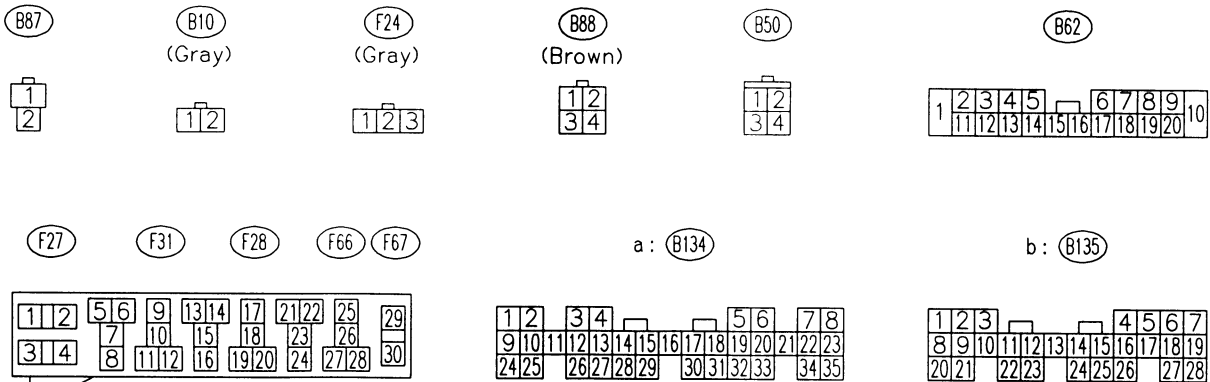
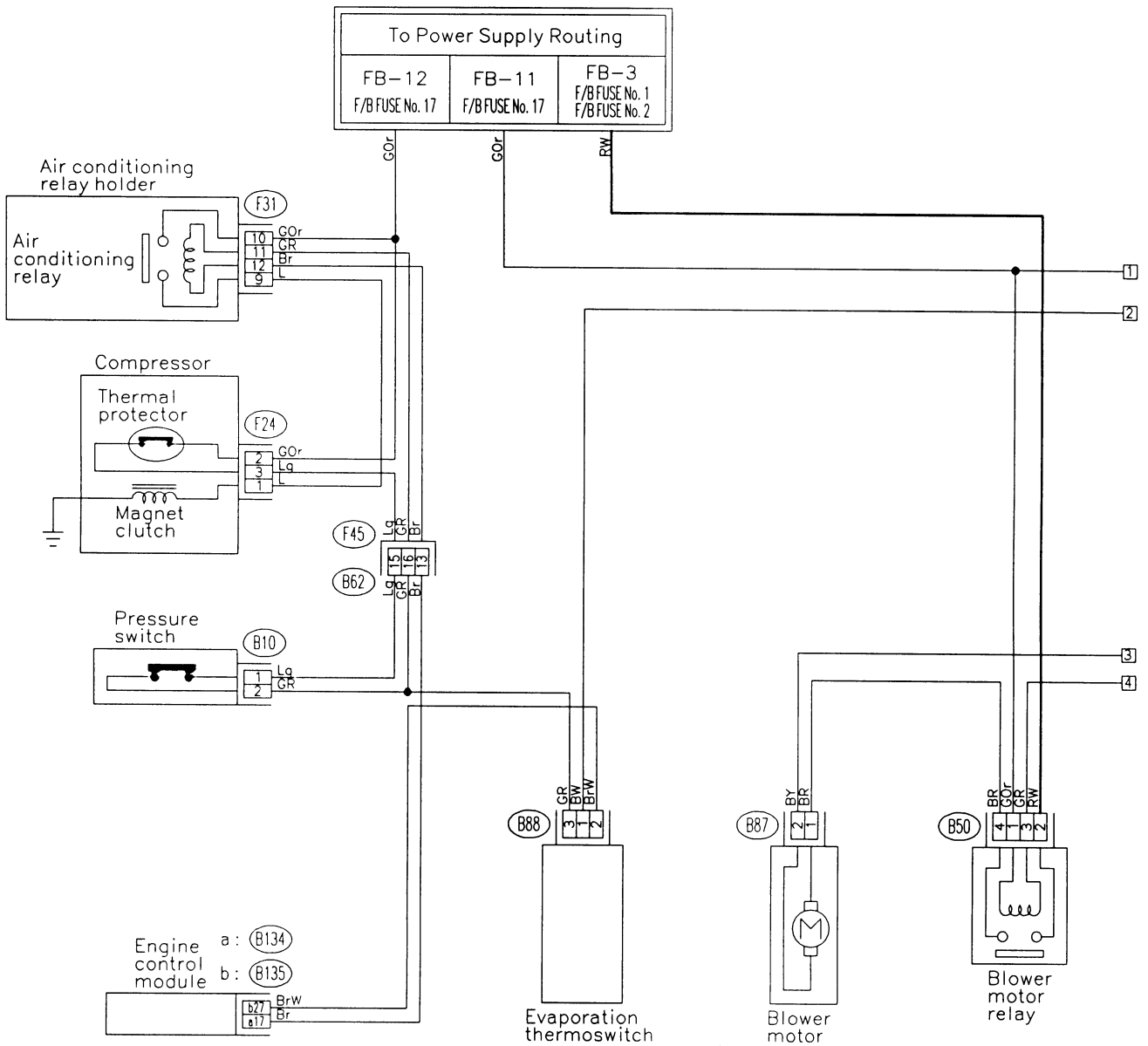



**6-3 [D5D0]**  
5. Wiring Diagram

**WIRING DIAGRAM**

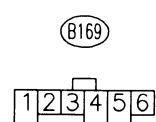
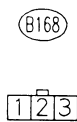
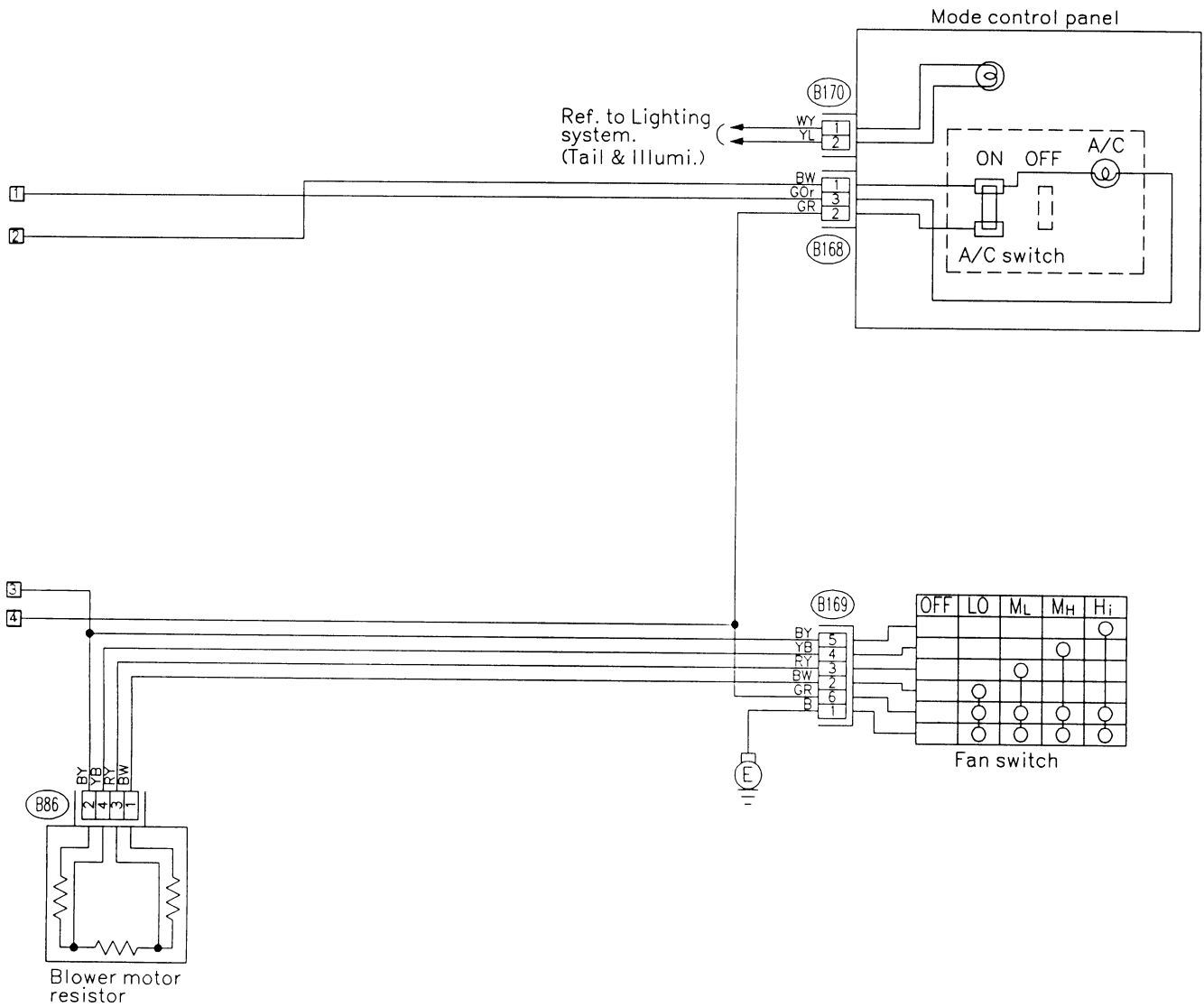

## E: ANTI-LOCK BRAKE SYSTEM

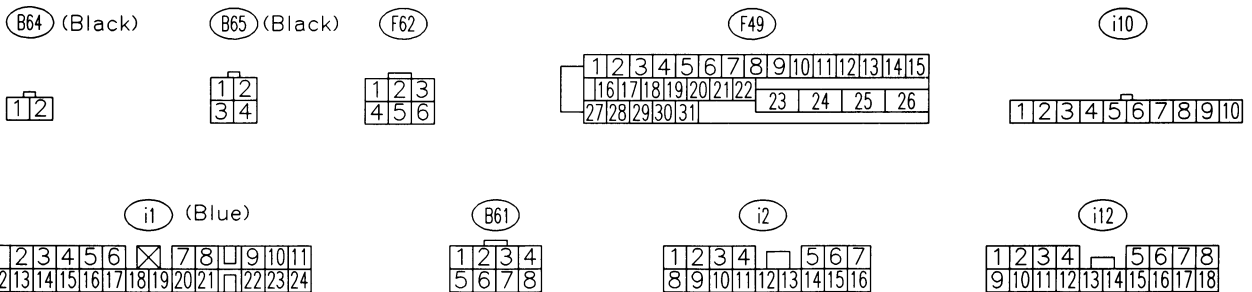
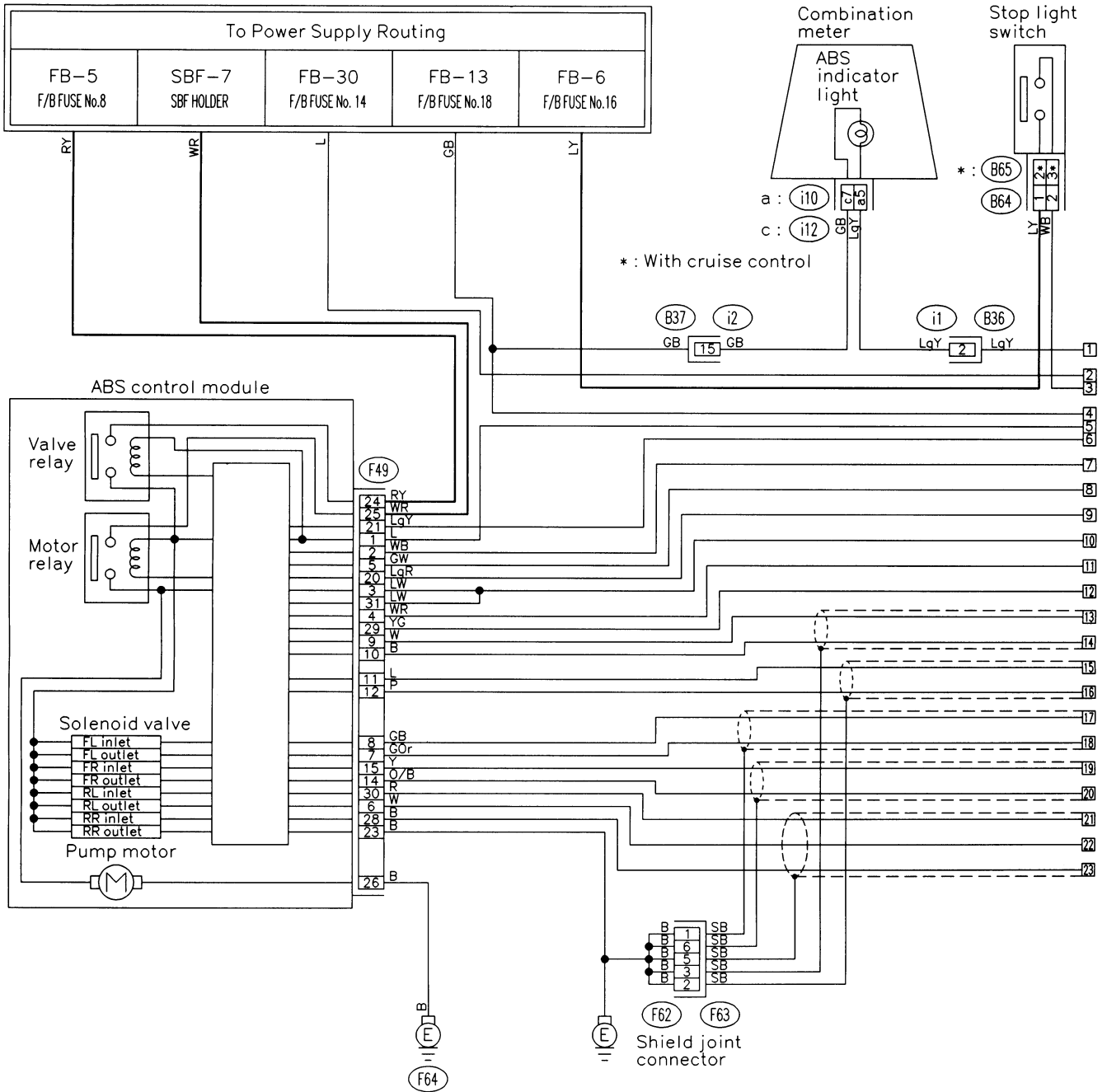

**6-3 [D5E0]**  
5. Wiring Diagram

**WIRING DIAGRAM**

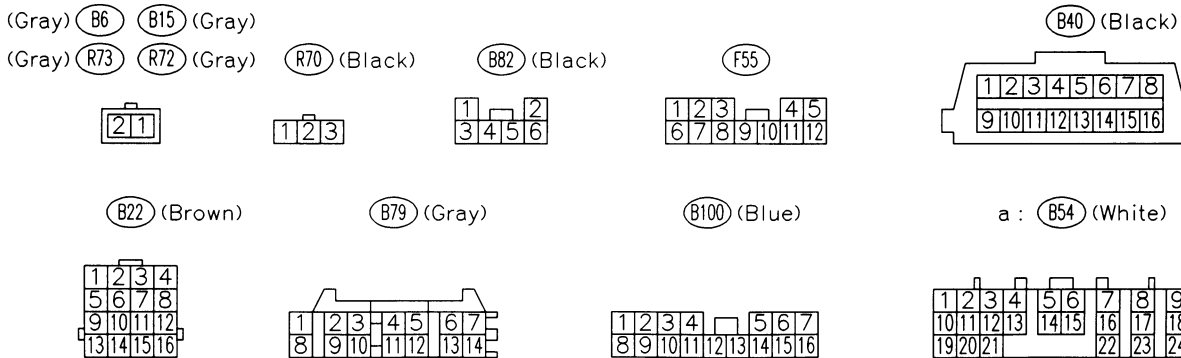
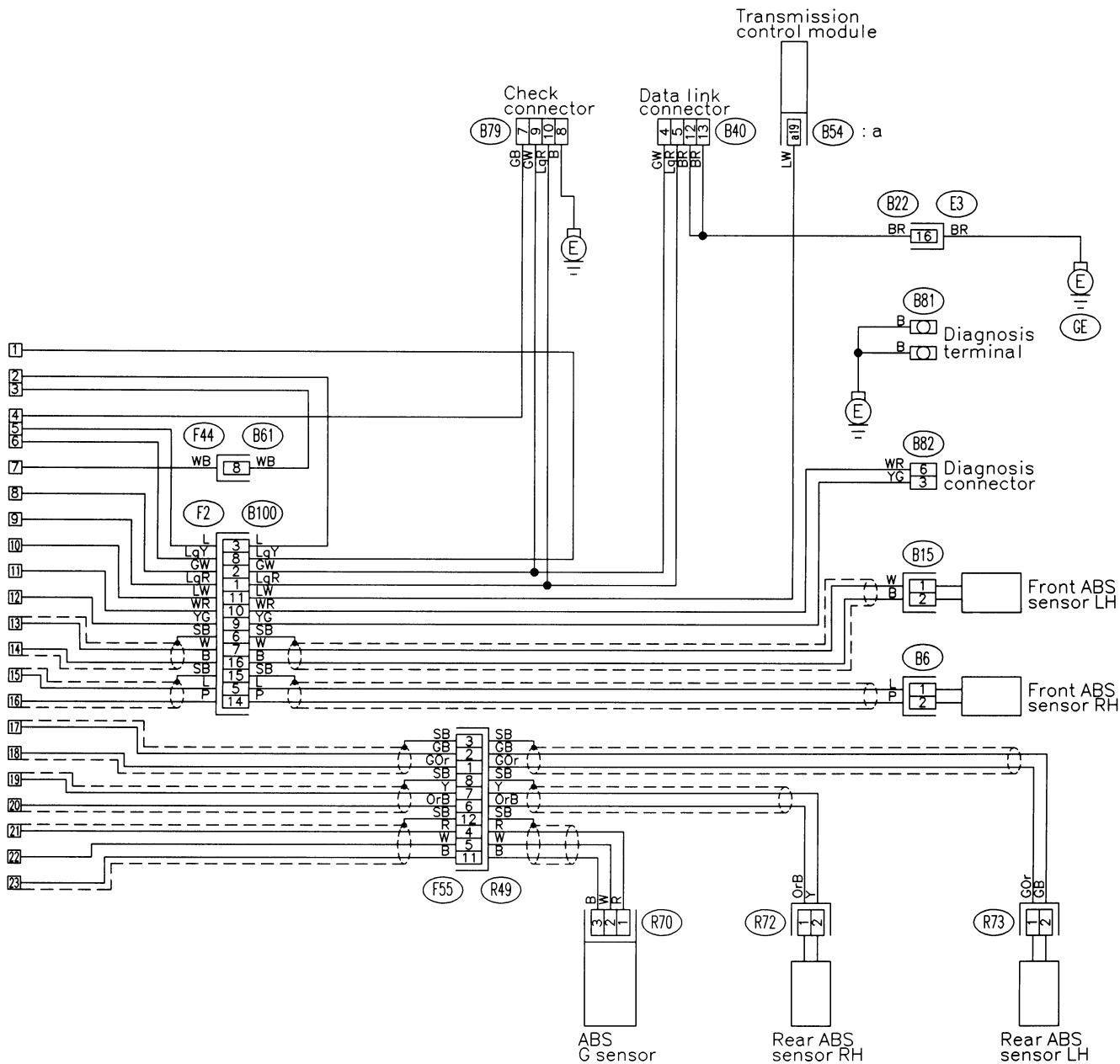

GU82-06B

# WIRING DIAGRAM

[D5F0] 6-3  
5. Wiring Diagram

## F: A/T CONTROL SYSTEM

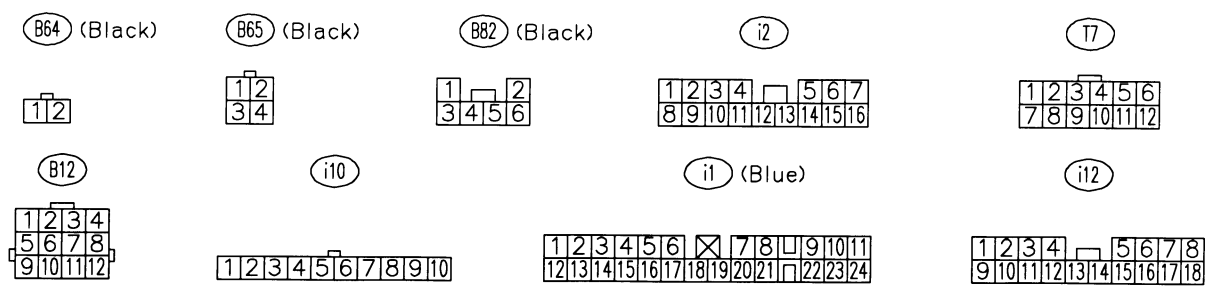
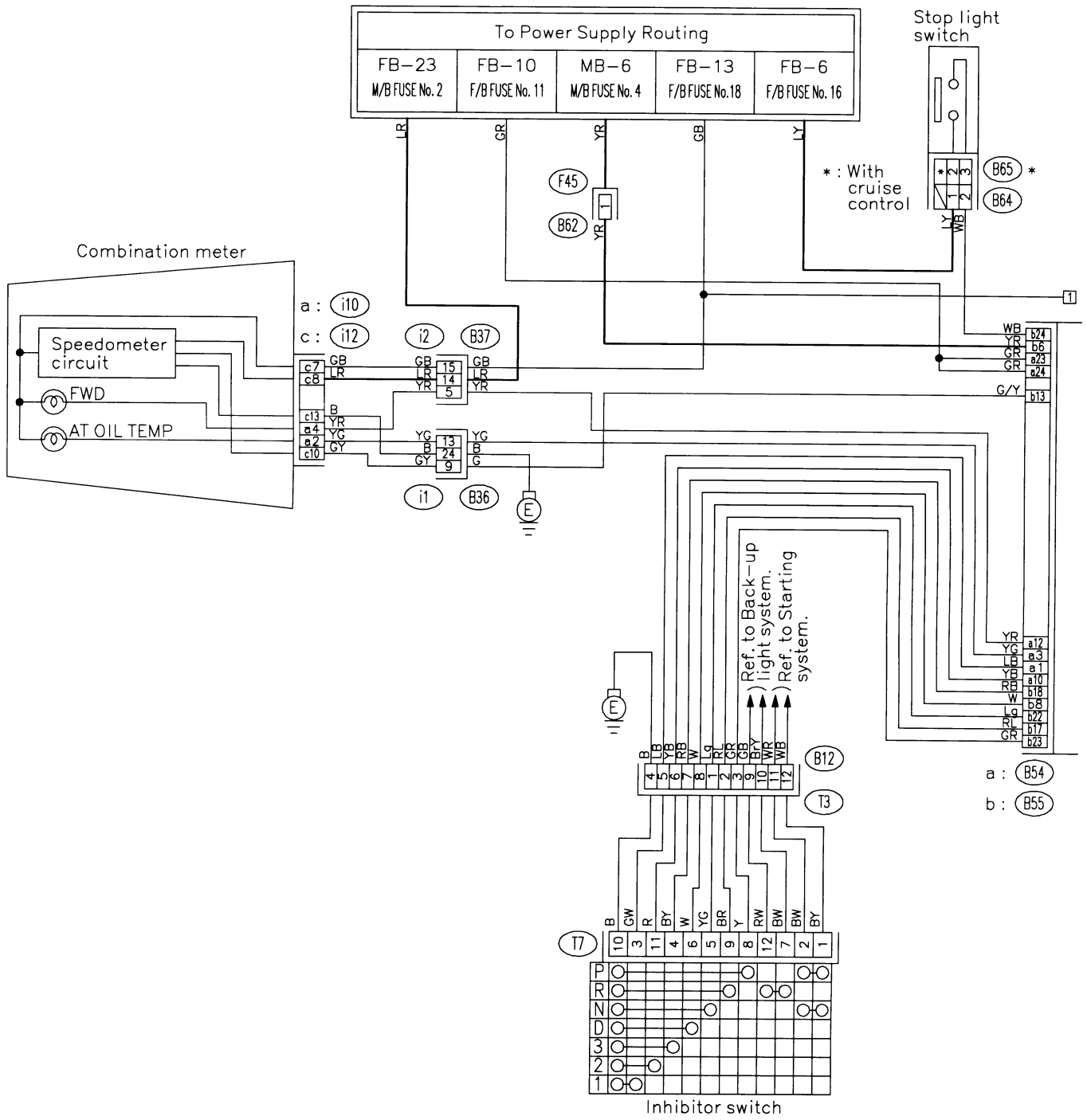

GU41-07A

**6-3 [D5F0]**  
**5. Wiring Diagram**

**WIRING DIAGRAM**

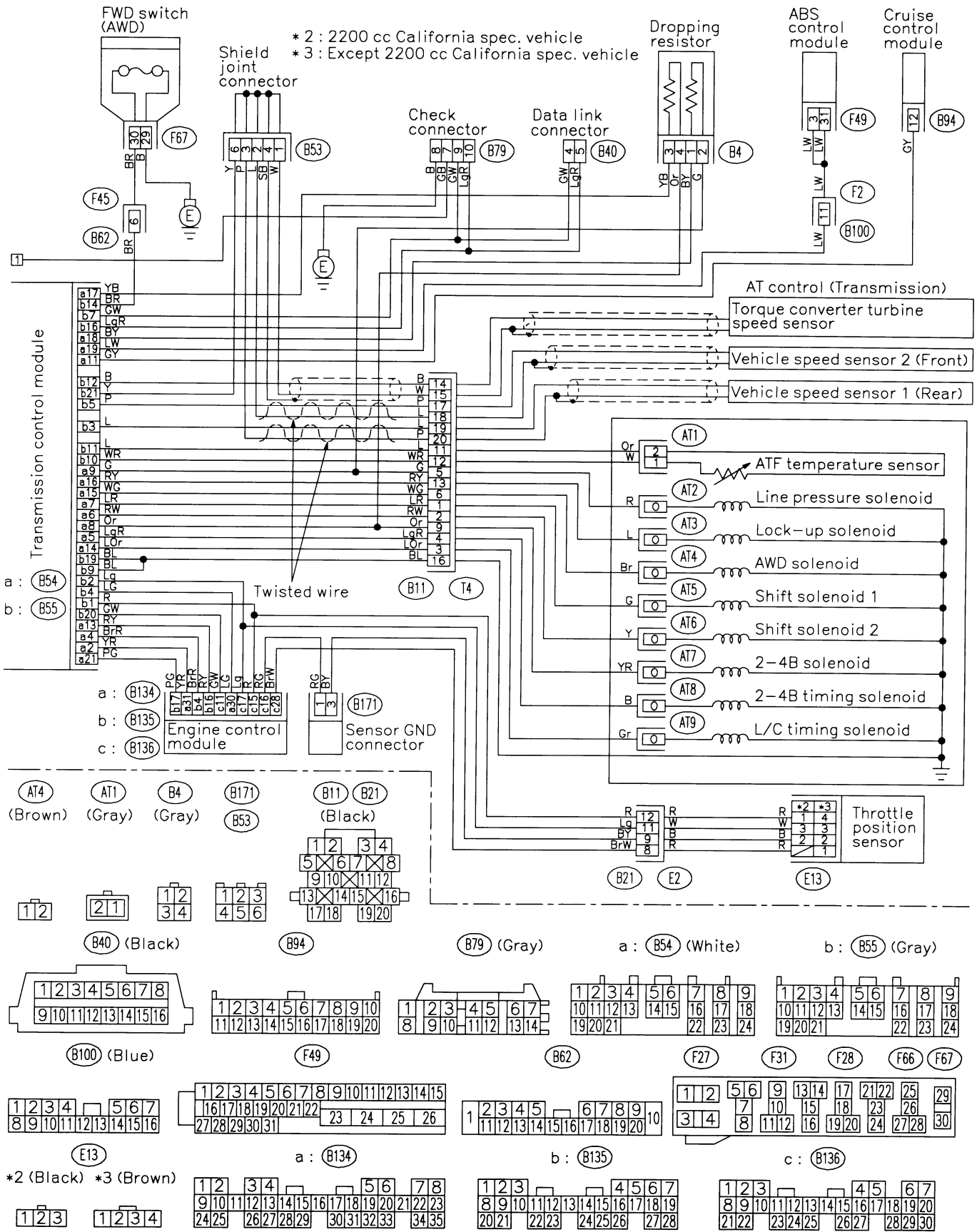

# WIRING DIAGRAM

[D5G0] **6-3**  
5. Wiring Diagram

## G: A/T SHIFT LOCK SYSTEM

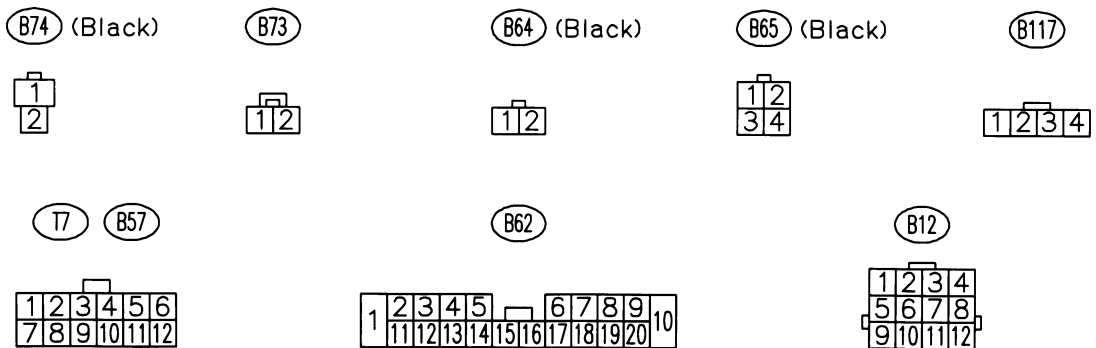
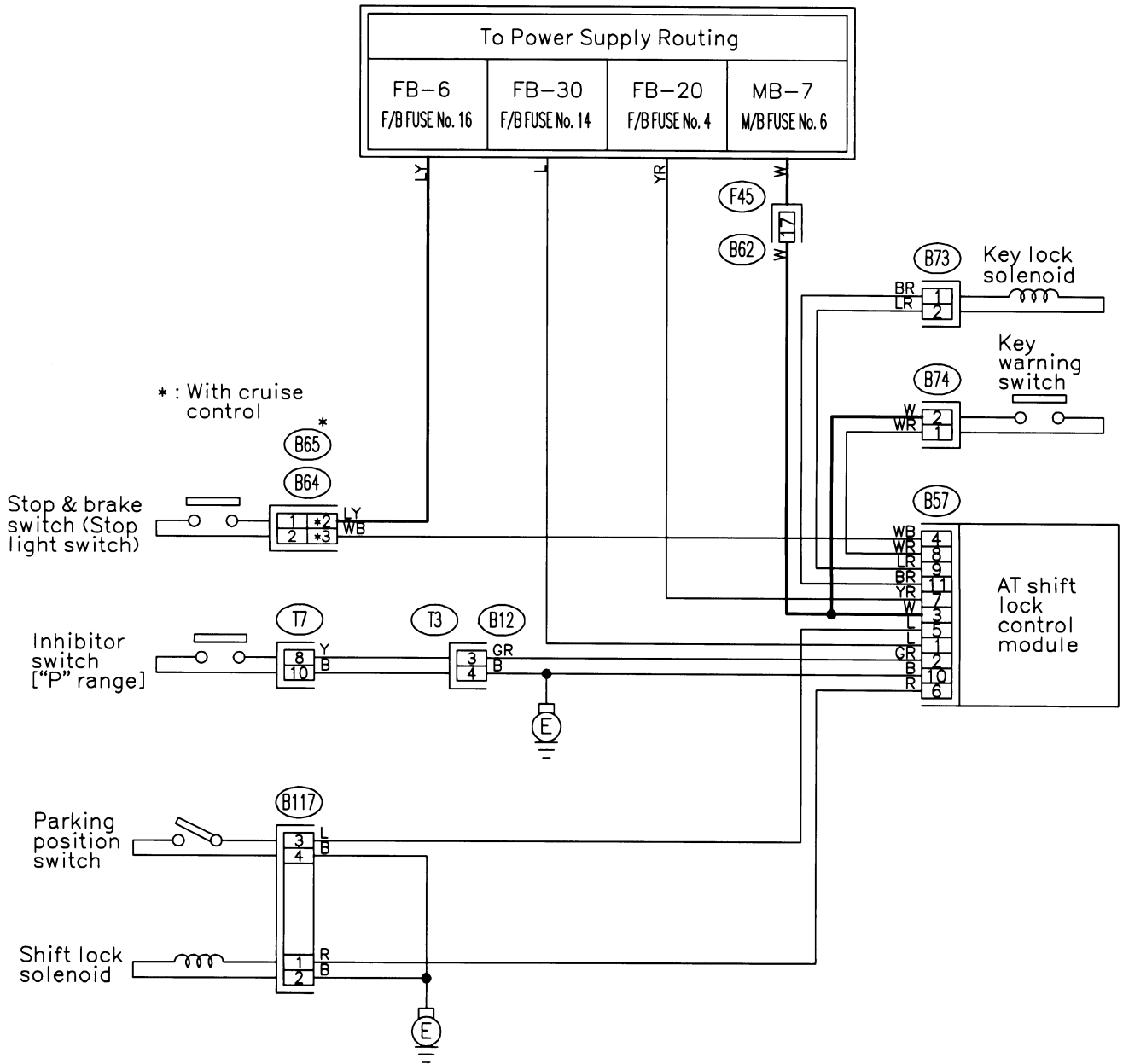

GU42-05

H: AUDIO SYSTEM

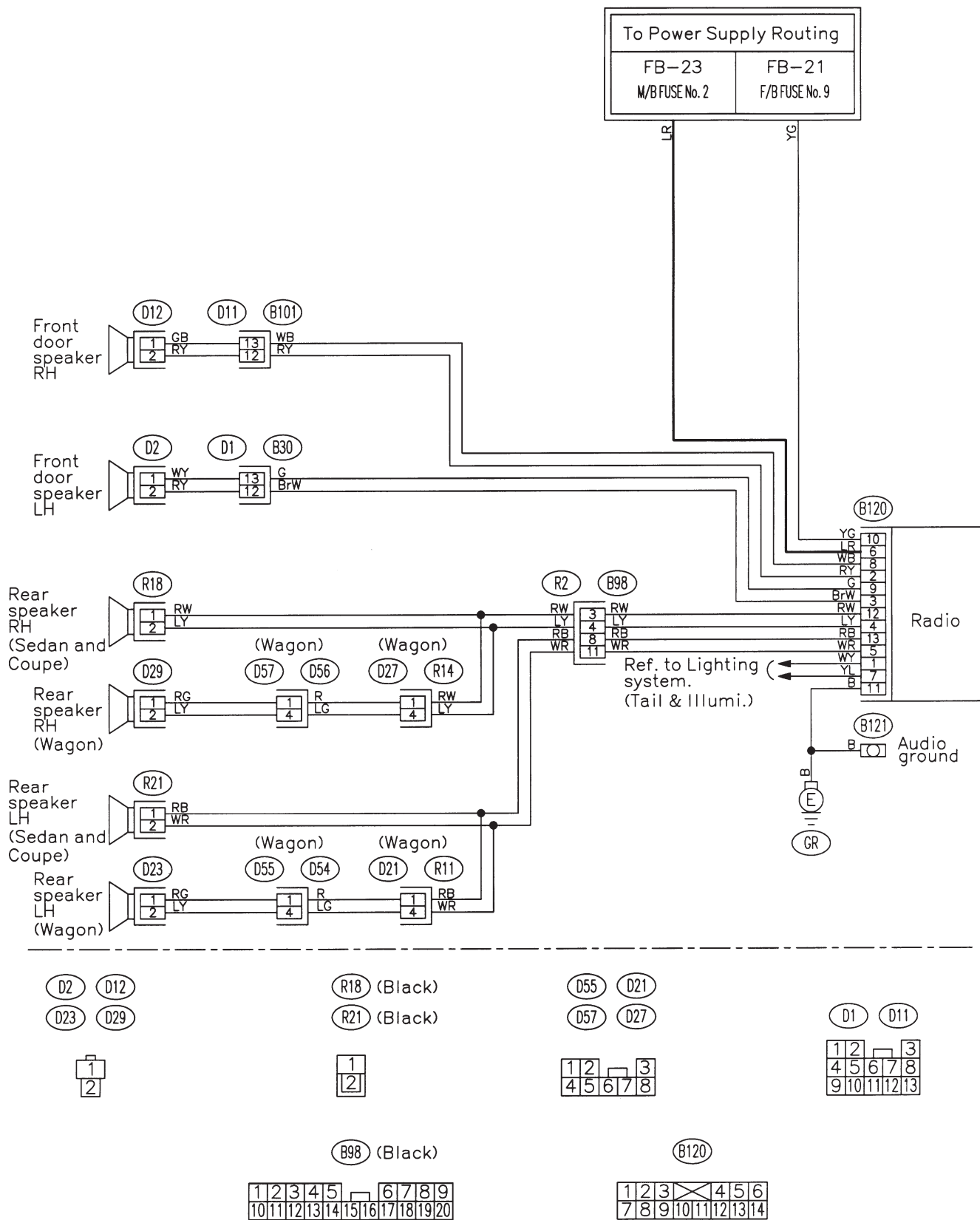

## I: CHARGING SYSTEM

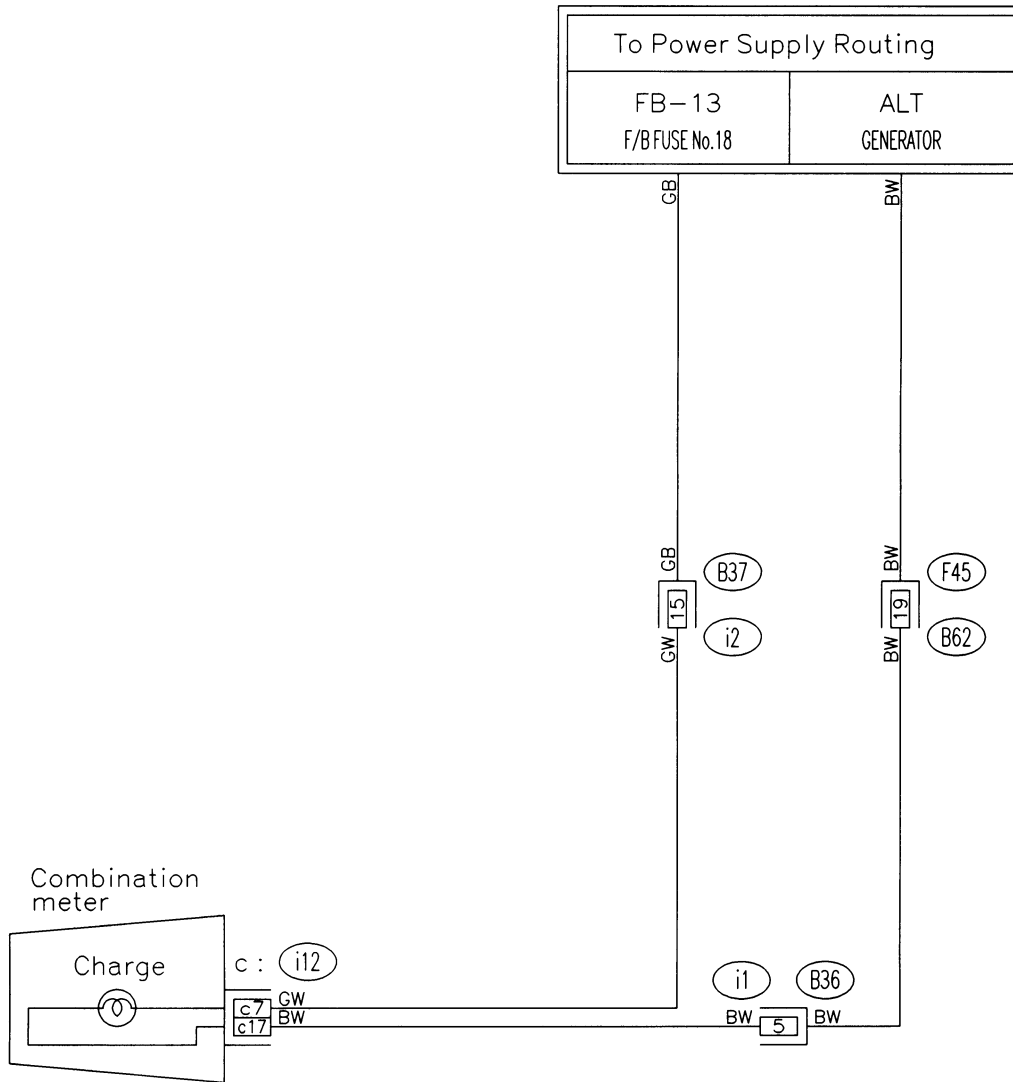

(B62)

1	2	3	4	5	6	7	8	9	10
11	12	13	14	15	16	17	18	19	20

(i1) (Blue)

1	2	3	4	5	6	7	8	9	10	11		
12	13	14	15	16	17	18	19	20	21	22	23	24

(i2)

1	2	3	4	5	6	7		
8	9	10	11	12	13	14	15	16

(i12)

1	2	3	4	5	6	7	8		
9	10	11	12	13	14	15	16	17	18

GU02-05



J: COMBINATION METER

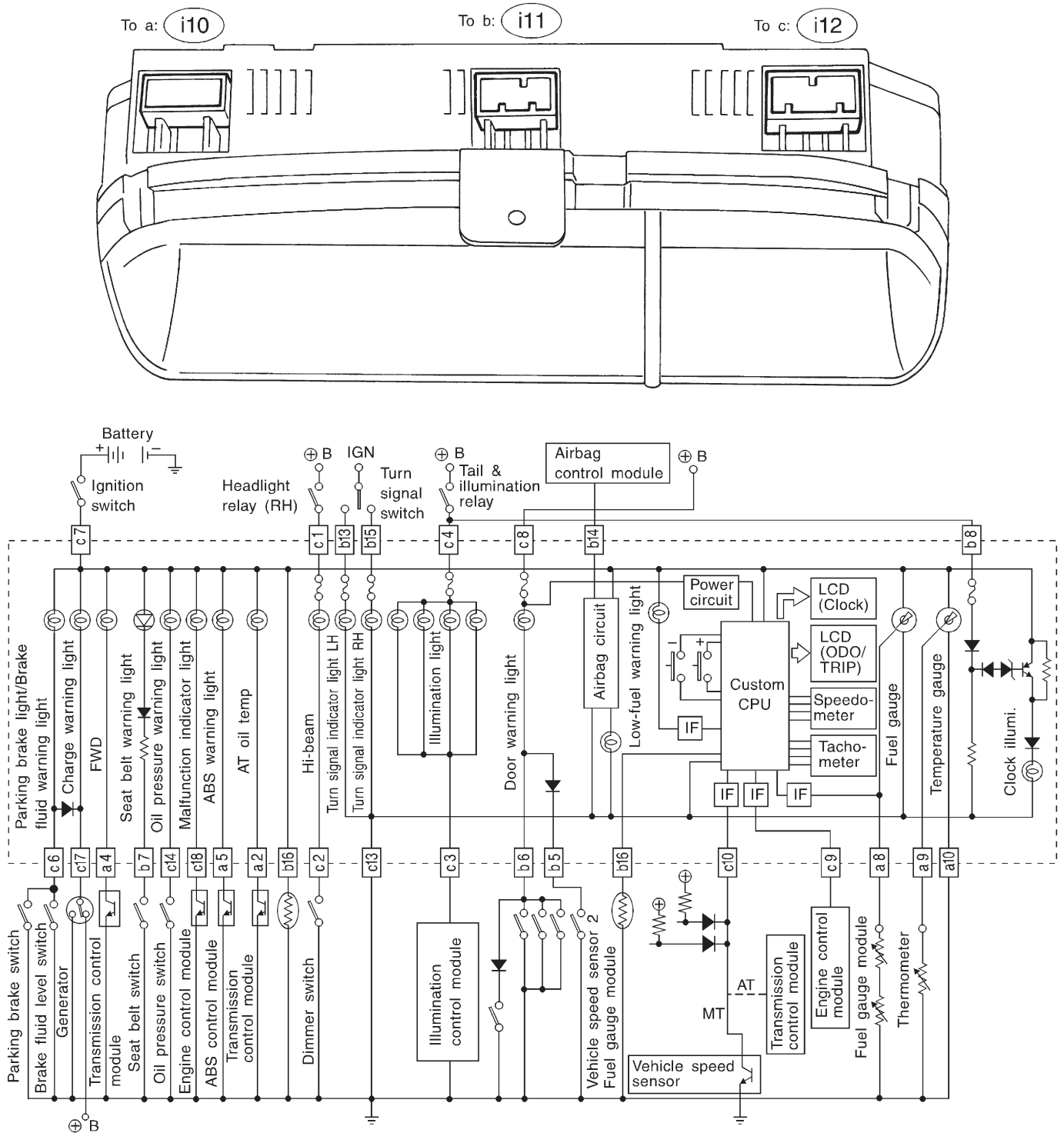

# WIRING DIAGRAM

[D5K0] 6-3  
5. Wiring Diagram

## K: DOOR LOCK SYSTEM

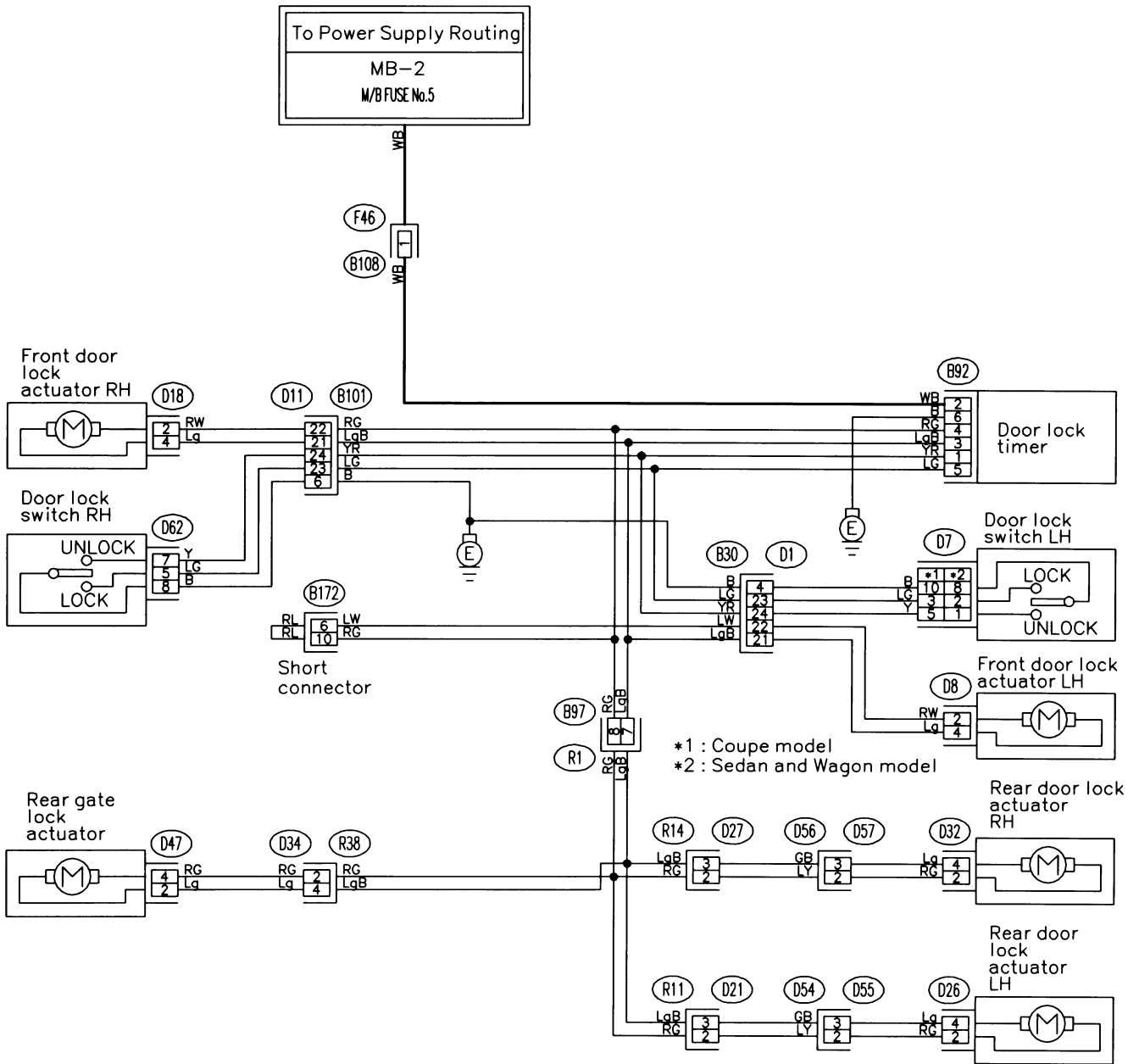

\*1 : Coupe model  
\*2 : Sedan and Wagon model

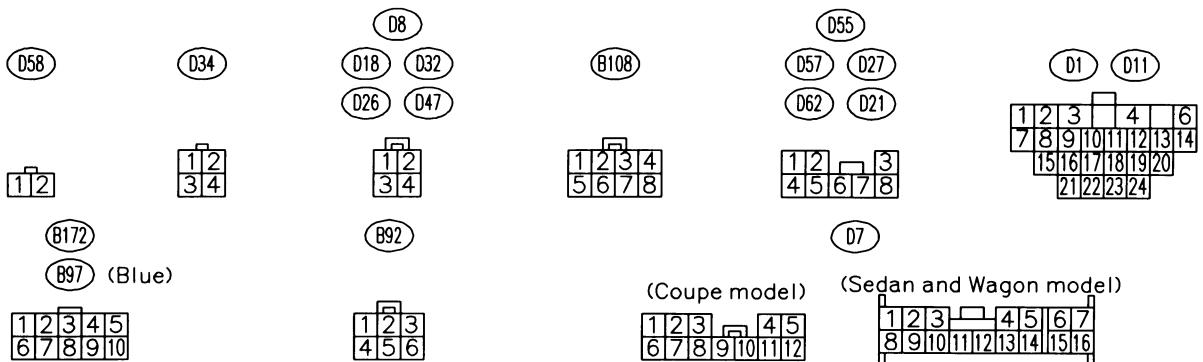

GU73-05

L: ENGINE ELECTRICAL SYSTEM

1. 2200 cc CALIFORNIA SPEC. VEHICLES

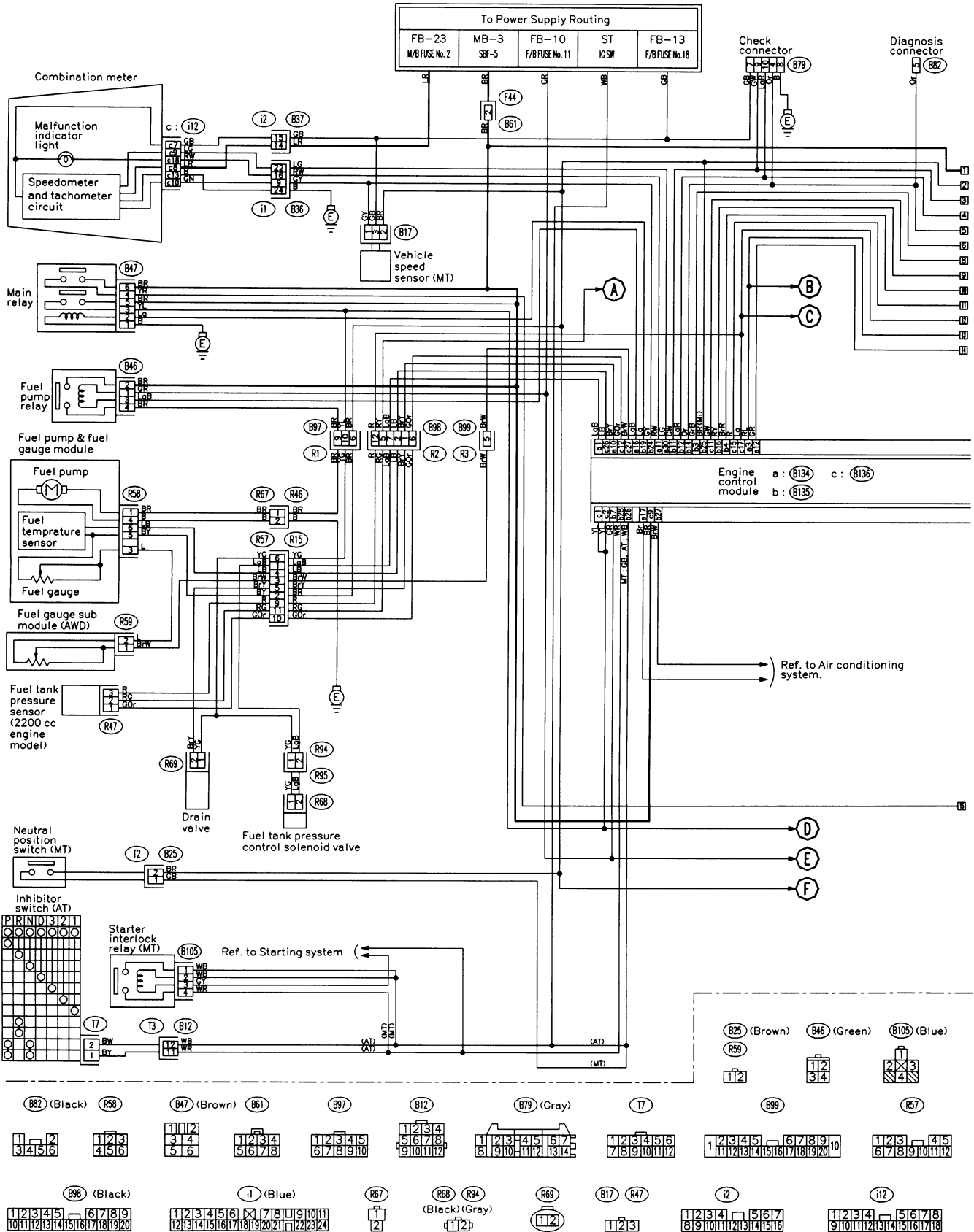

# WIRING DIAGRAM

[D5L1] 6-3  
5. Wiring Diagram

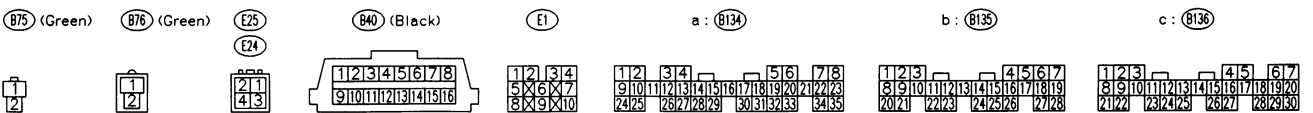
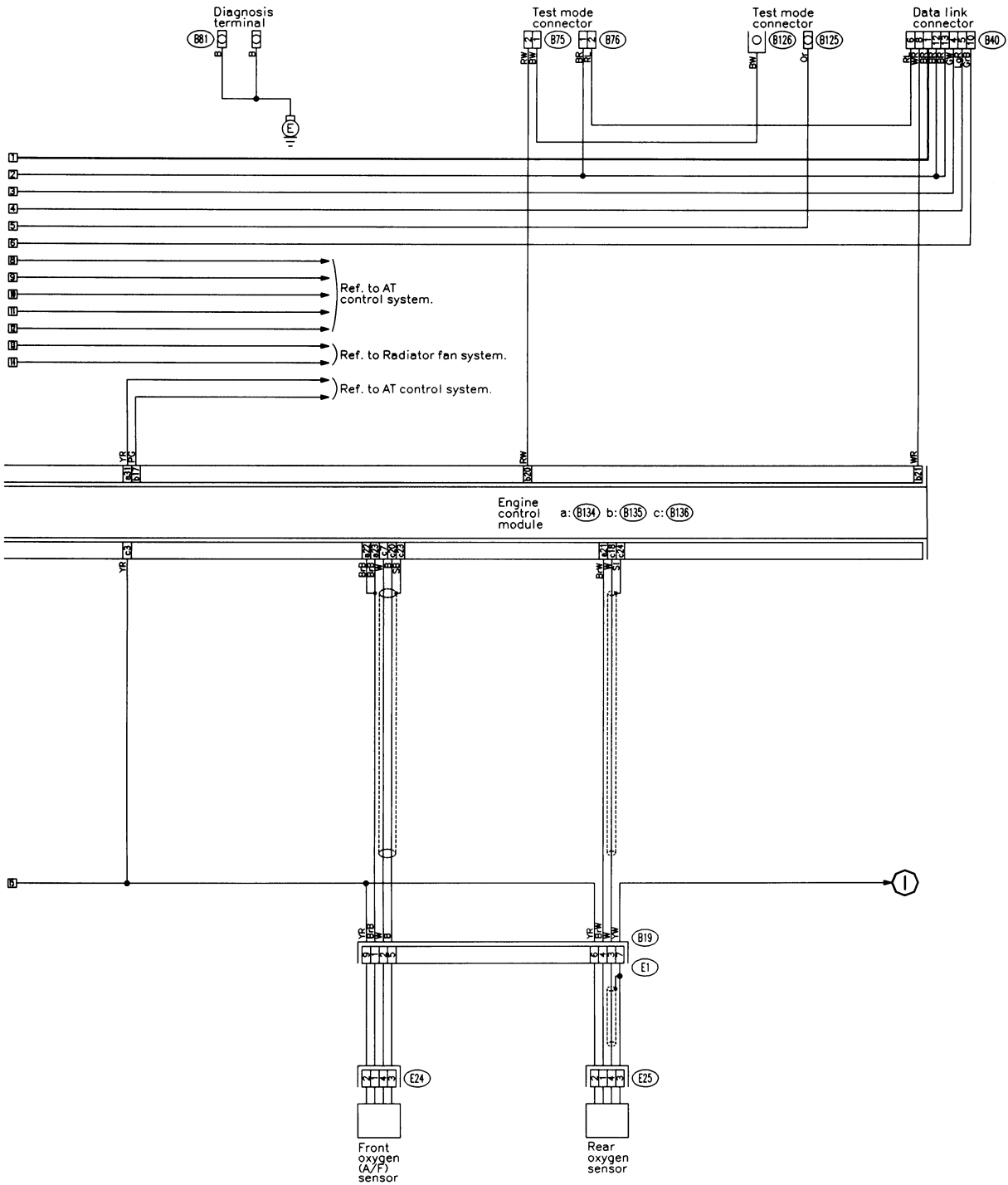

**6-3 [D5L1]**  
5. Wiring Diagram

**WIRING DIAGRAM**

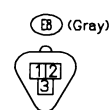
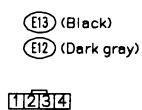
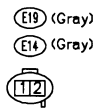
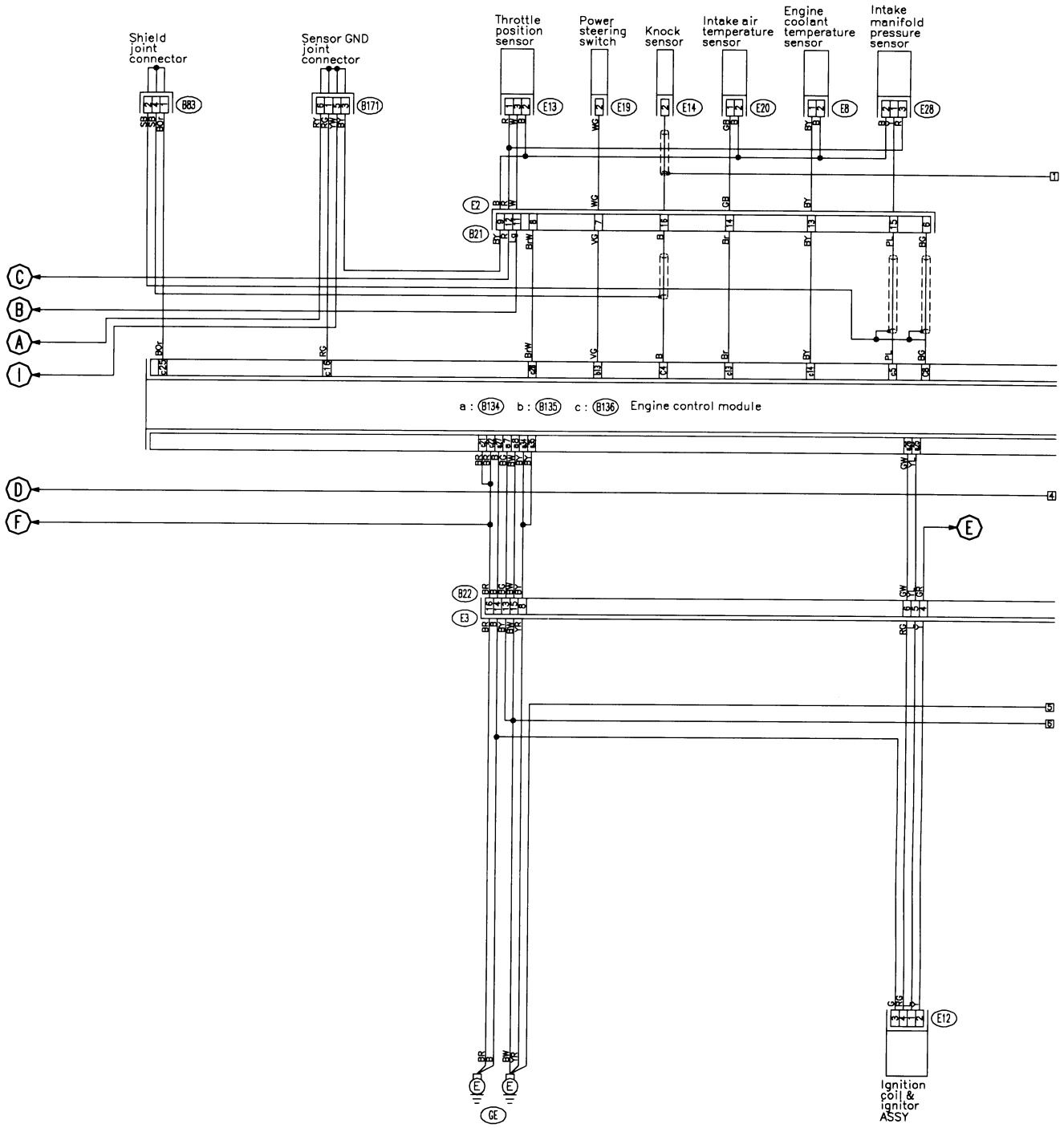

# WIRING DIAGRAM

[D5L1] 6-3  
5. Wiring Diagram

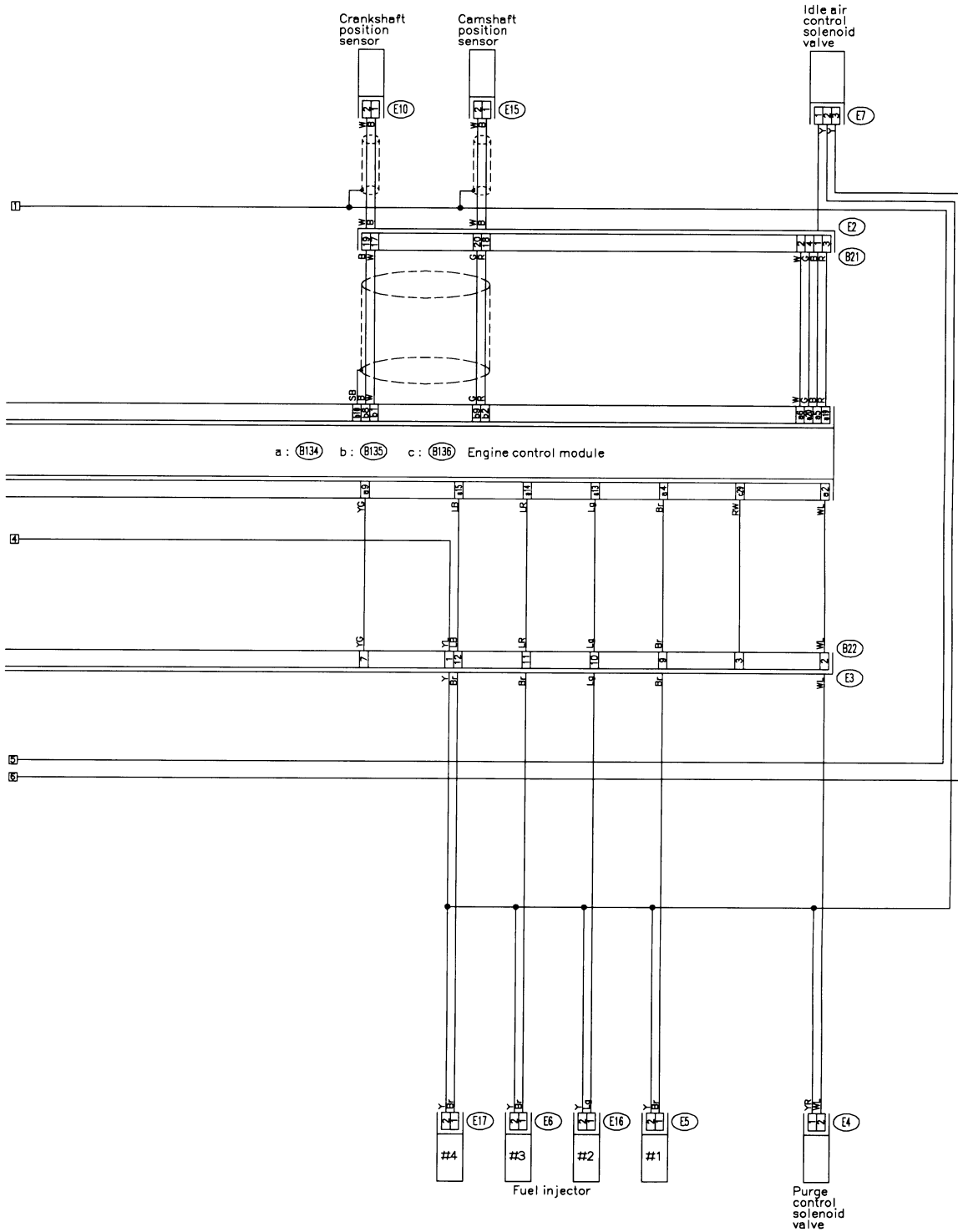

(Black) (E10) (E15) (Black)  
(Black) (E5) (E16) (Black)  
(Black) (E6) (E17) (Black)

(E22) (Grey)  
(E4) (Black)

(E7)

(B21)  

1	2	3	4
5	6	7	8
9	10	11	12
13	14	15	16
17	18	19	20

a: (B134)

b: (B135)

c: (B136)

1	2	3	4	5	6	7	8
9	10	11	12	13	14	15	16
17	18	19	20	21	22	23	24
25	26	27	28	29	30	31	32
33	34	35					

1	2	3	4	5	6	7
8	9	10	11	12	13	14
15	16	17	18	19	20	21
22	23	24	25	26	27	28

1	2	3	4	5	6	7
8	9	10	11	12	13	14
15	16	17	18	19	20	21
22	23	24	25	26	27	28
29	30					



**6-3 [D5L2]**  
 5. Wiring Diagram

**WIRING DIAGRAM**

**2. EXCEPT 2200 cc CALIFORNIA SPEC. VEHICLES**

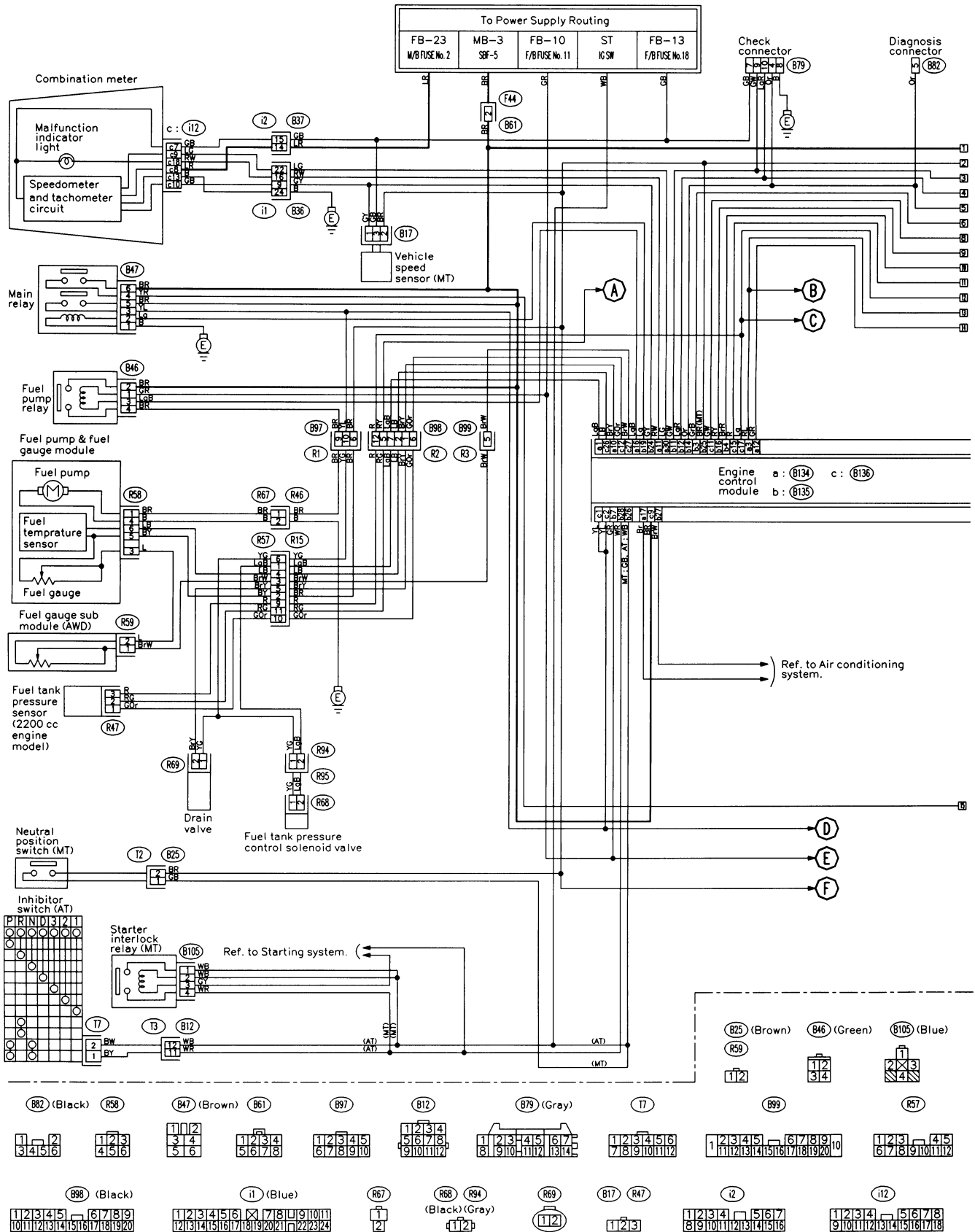

# WIRING DIAGRAM

[D5L2] 6-3  
5. Wiring Diagram

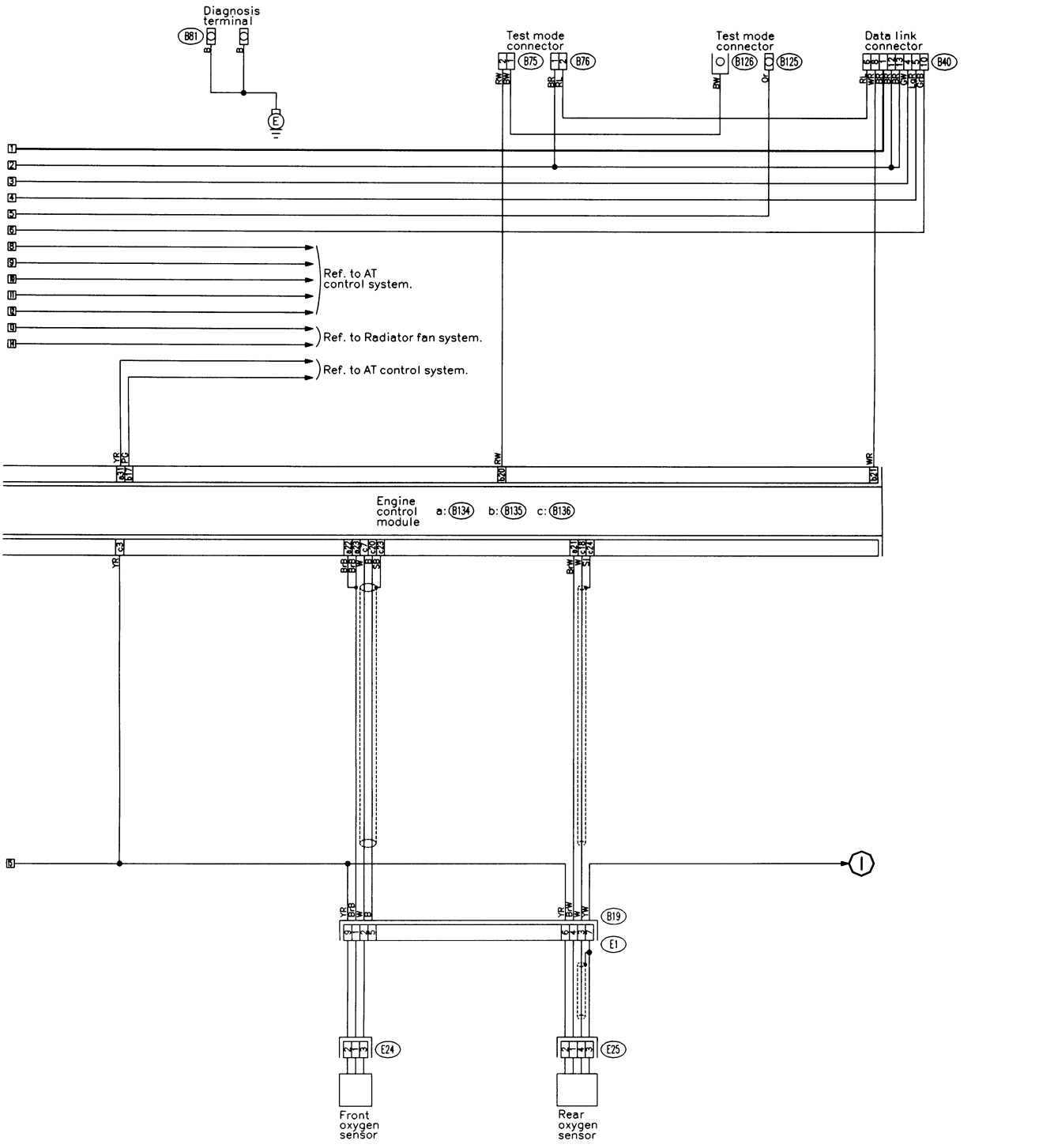

(B75) (Green)   (B76) (Green)   (E25)   (E24)   (B40) (Black)   (E1)   a: (B134)   b: (B135)   c: (B136)

1	2	3	4	5	6	7	8	9	10	11	12	13	14	15	16	17	18	19	20	21	22	23	24	25	26	27	28	29	30	31	32	33	34	35
1	2	3	4	5	6	7	8	9	10	11	12	13	14	15	16	17	18	19	20	21	22	23	24	25	26	27	28	29	30	31	32	33	34	35



**6-3 [D5L2]**  
**5. Wiring Diagram**

**WIRING DIAGRAM**

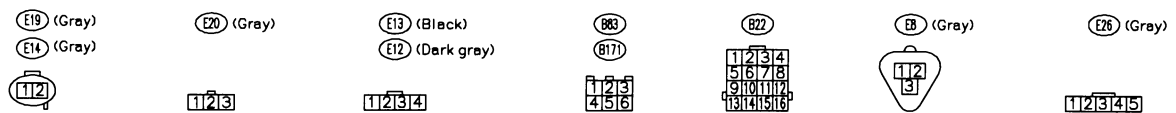
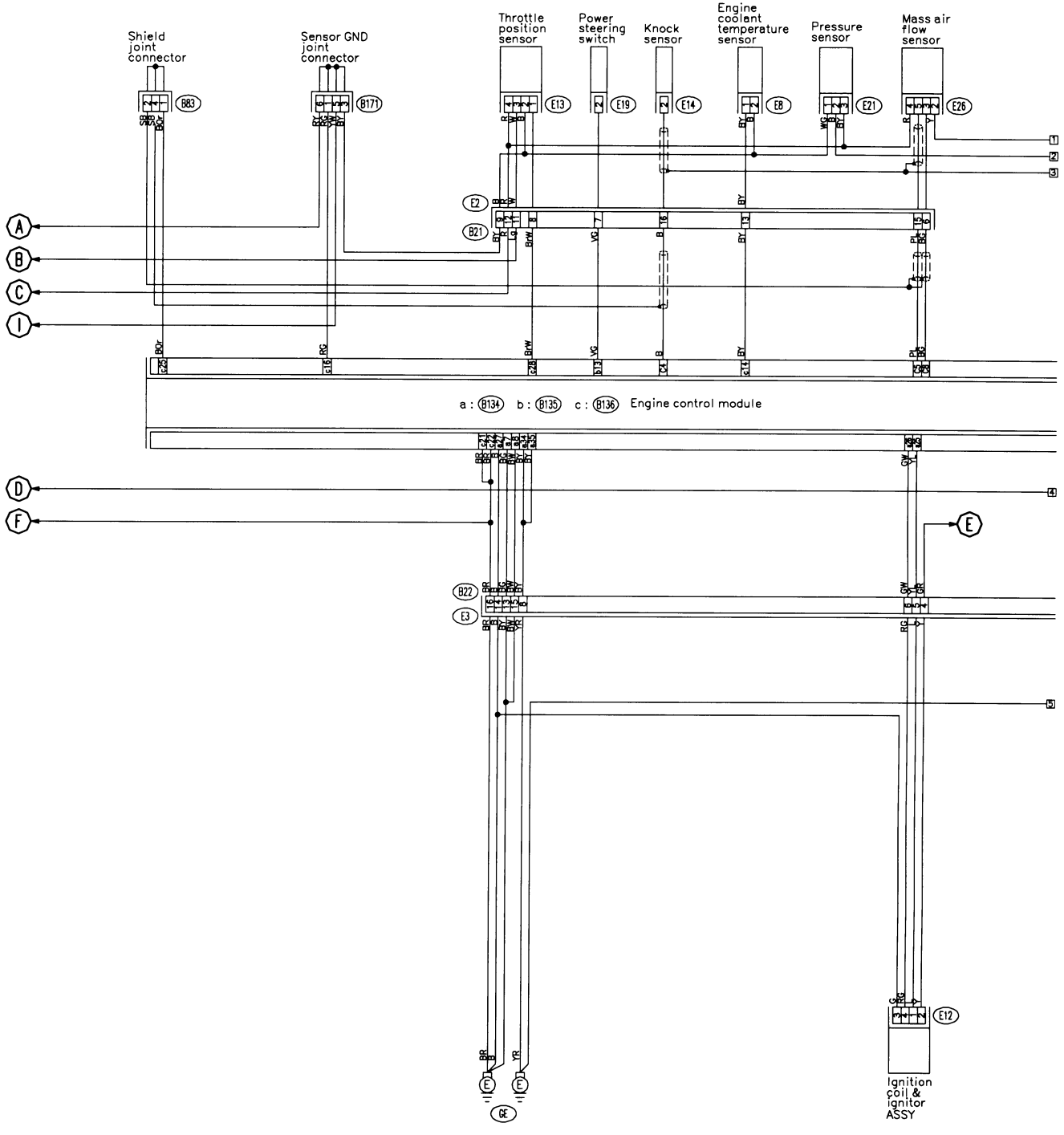

# WIRING DIAGRAM

[D5L2] 6-3  
5. Wiring Diagram

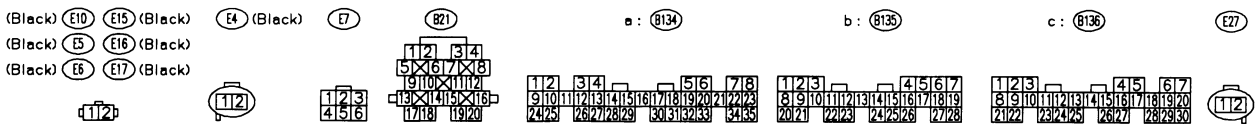
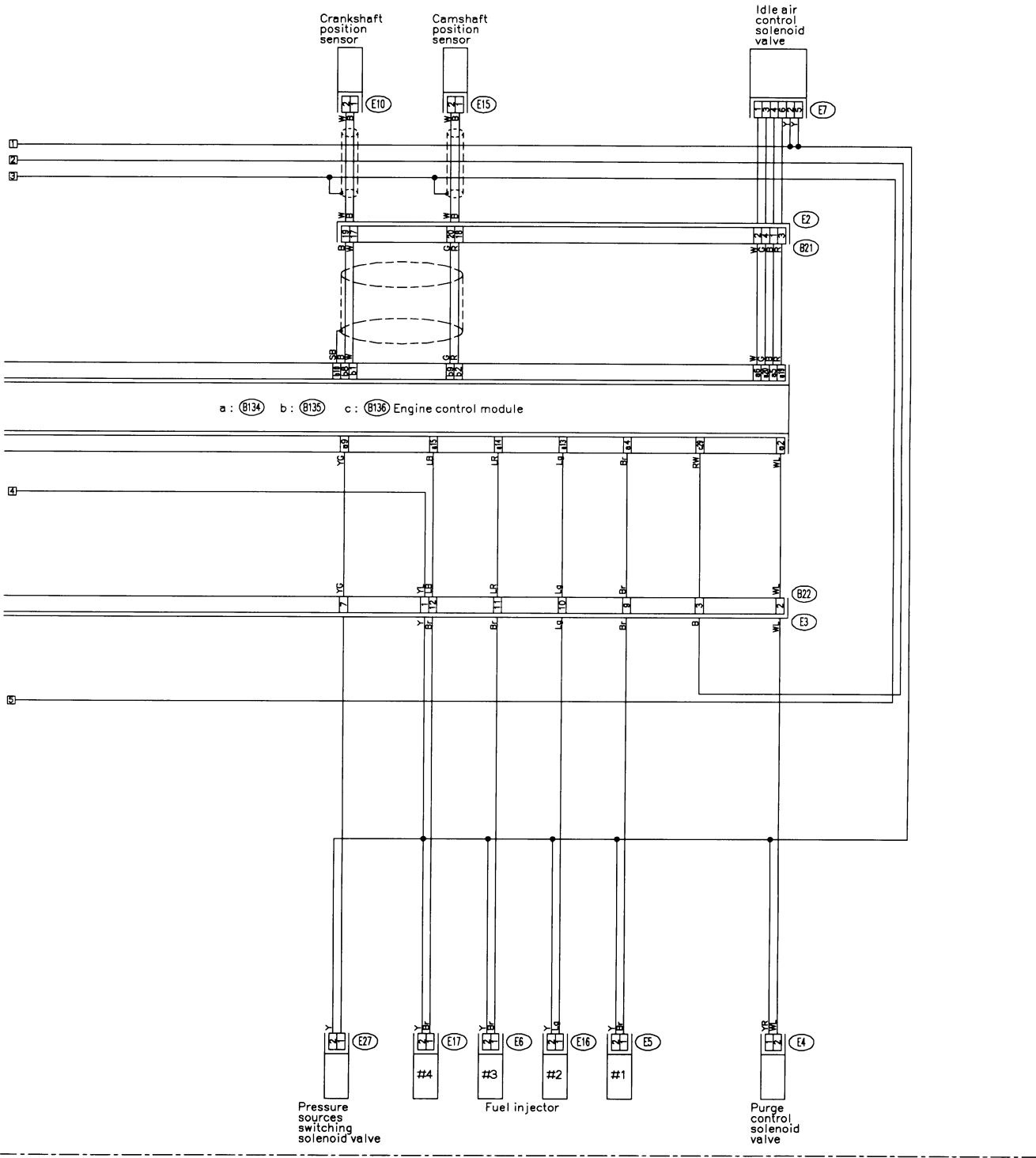

M: FUEL GAUGE SYSTEM

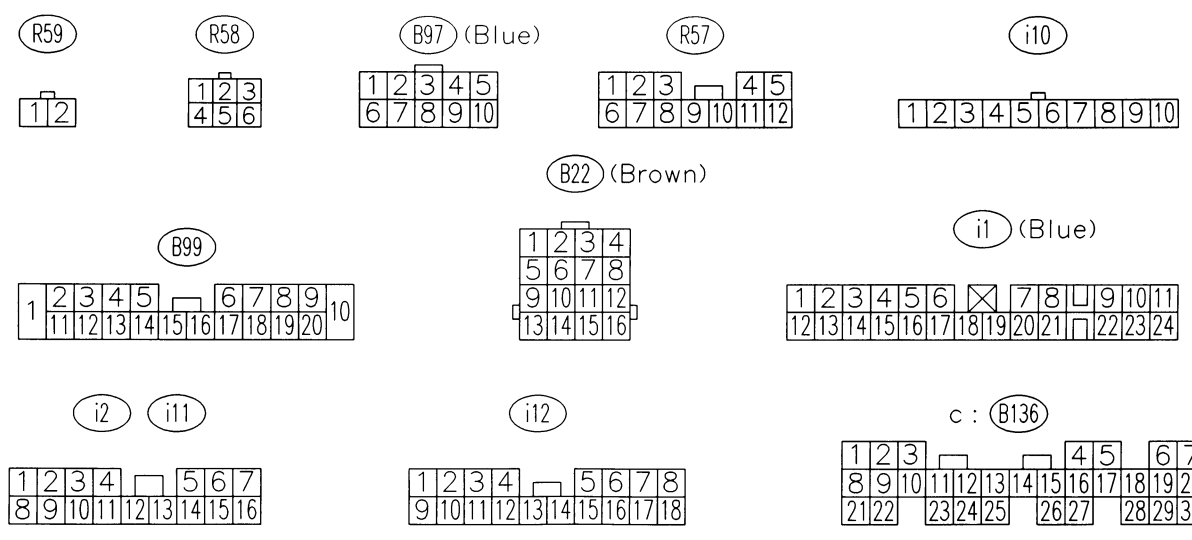
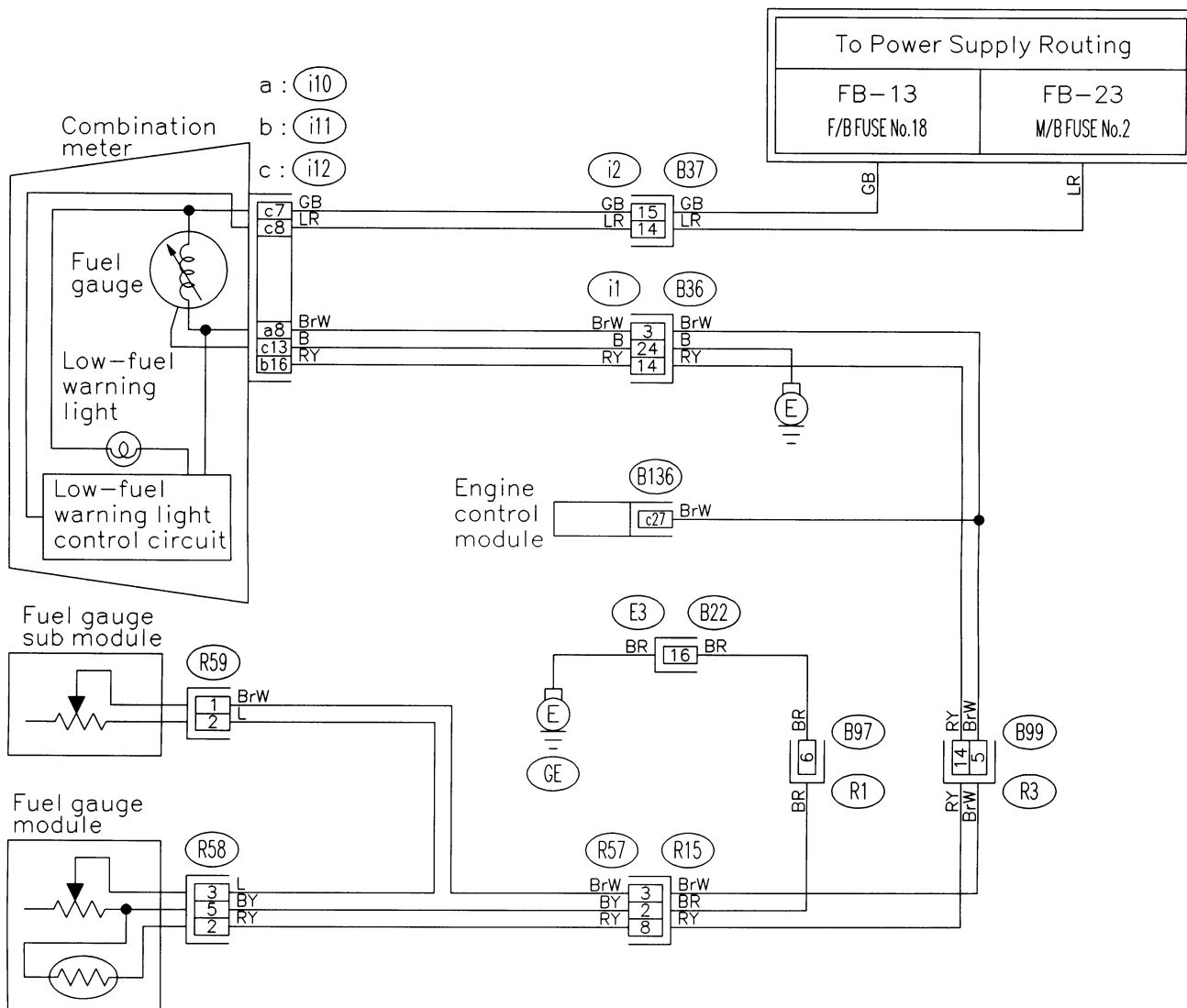

# WIRING DIAGRAM

## N: HORN AND FRONT ACCESSORY POWER SUPPLY SYSTEM

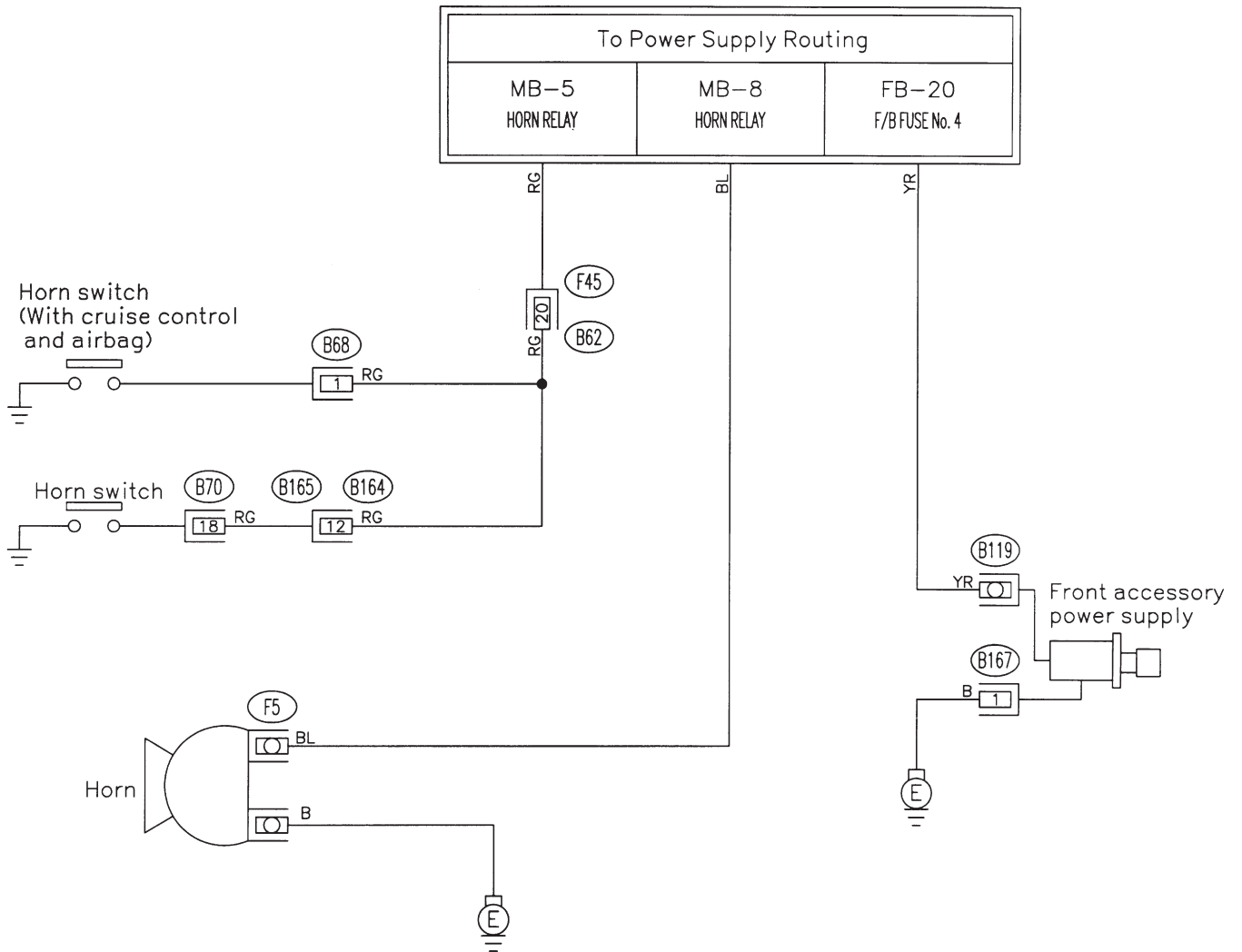

(B167)



(B68) (Black)



(B70)

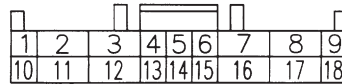

(B164)

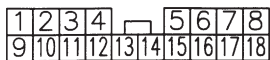

(B62)

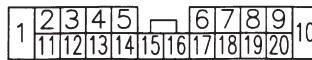

O: LIGHTING SYSTEM (BACK-UP LIGHT)

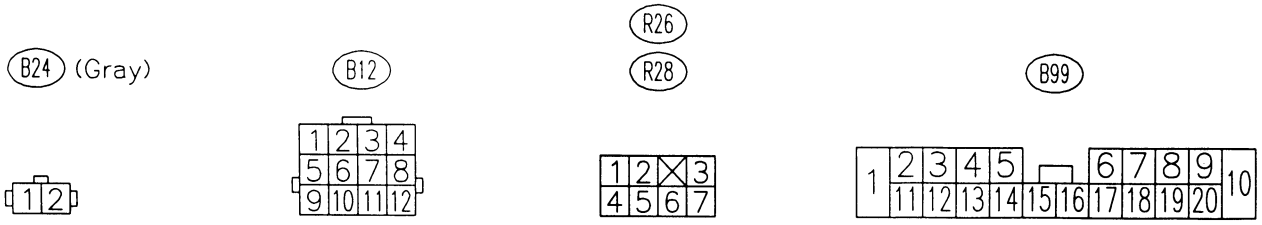
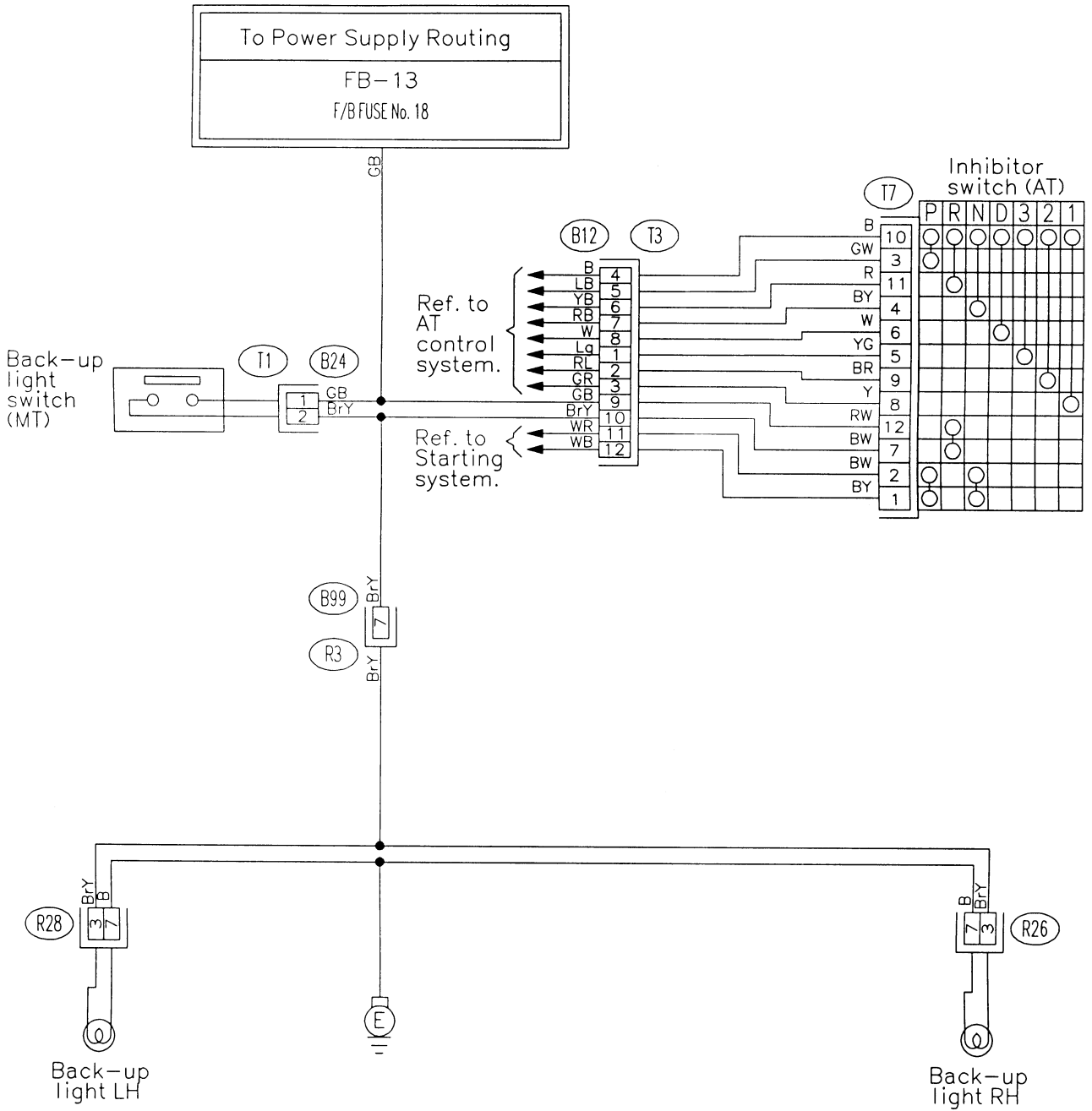

# WIRING DIAGRAM

## P: LIGHTING SYSTEM (CLEARANCE LIGHT AND ILLUMINATION LIGHT)

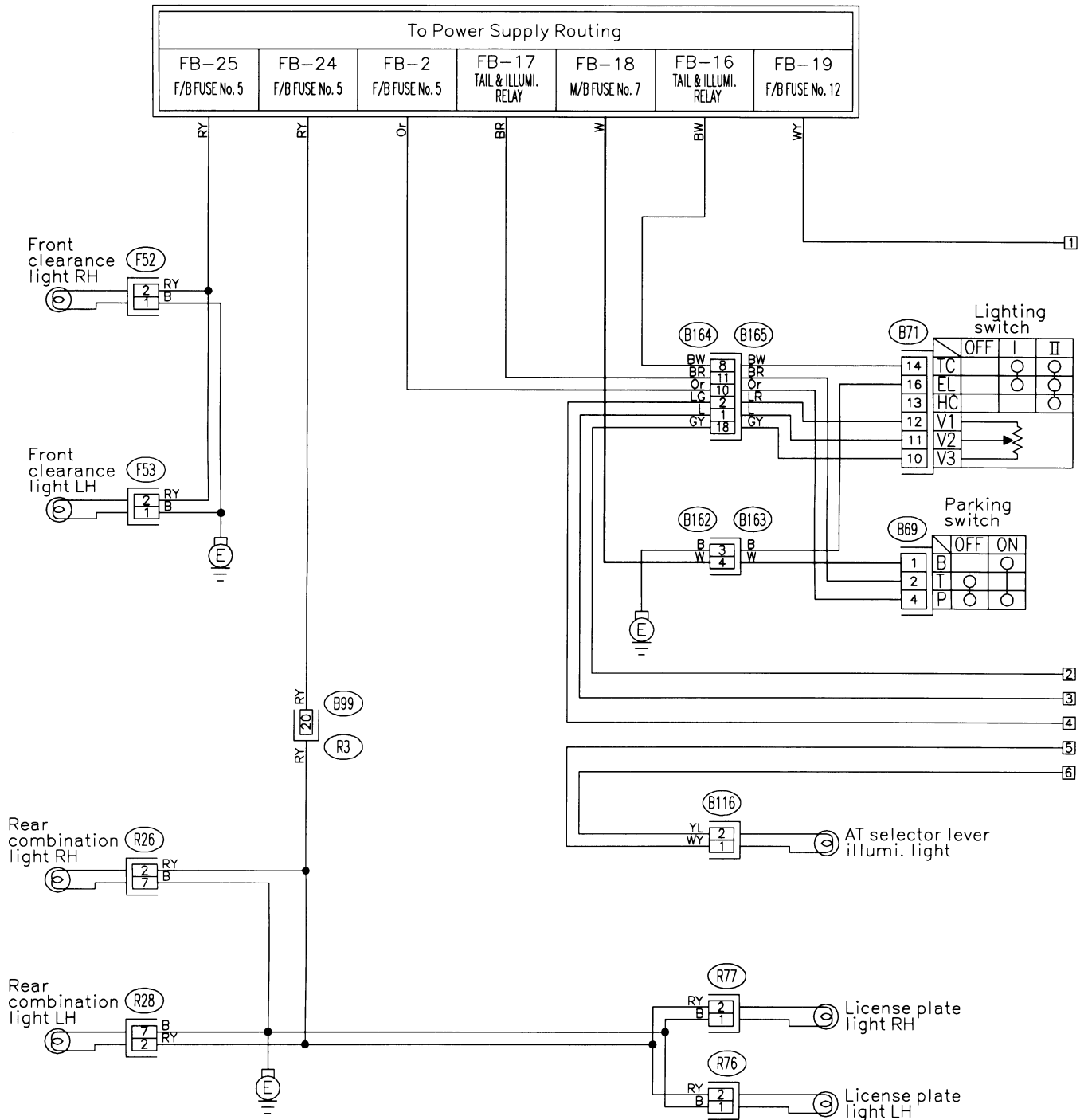

(F53) (Gray)  
(F52) (Gray)

(R77)  
(R76)

(B116) (Black)

(B69)

(B71)

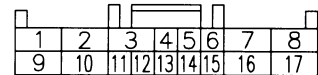
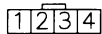

(R26) (R28)

(B162)

(B164)

(B99)

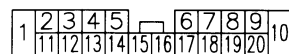
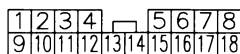
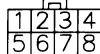

GU21-06A

**6-3 [D5P0]**  
**5. Wiring Diagram**

**WIRING DIAGRAM**

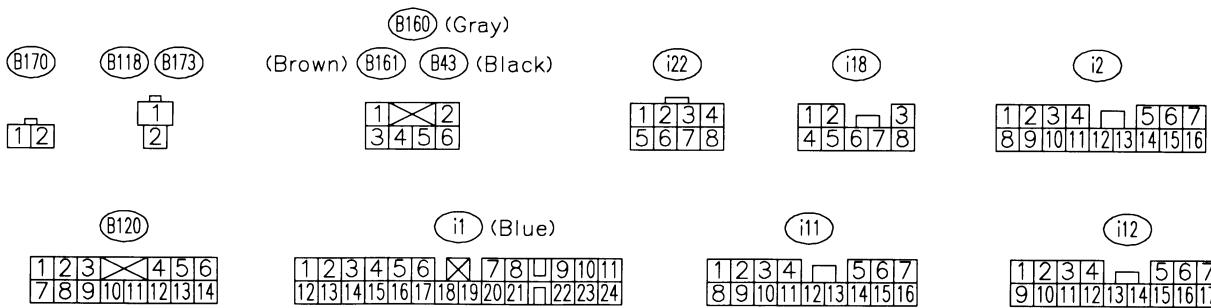
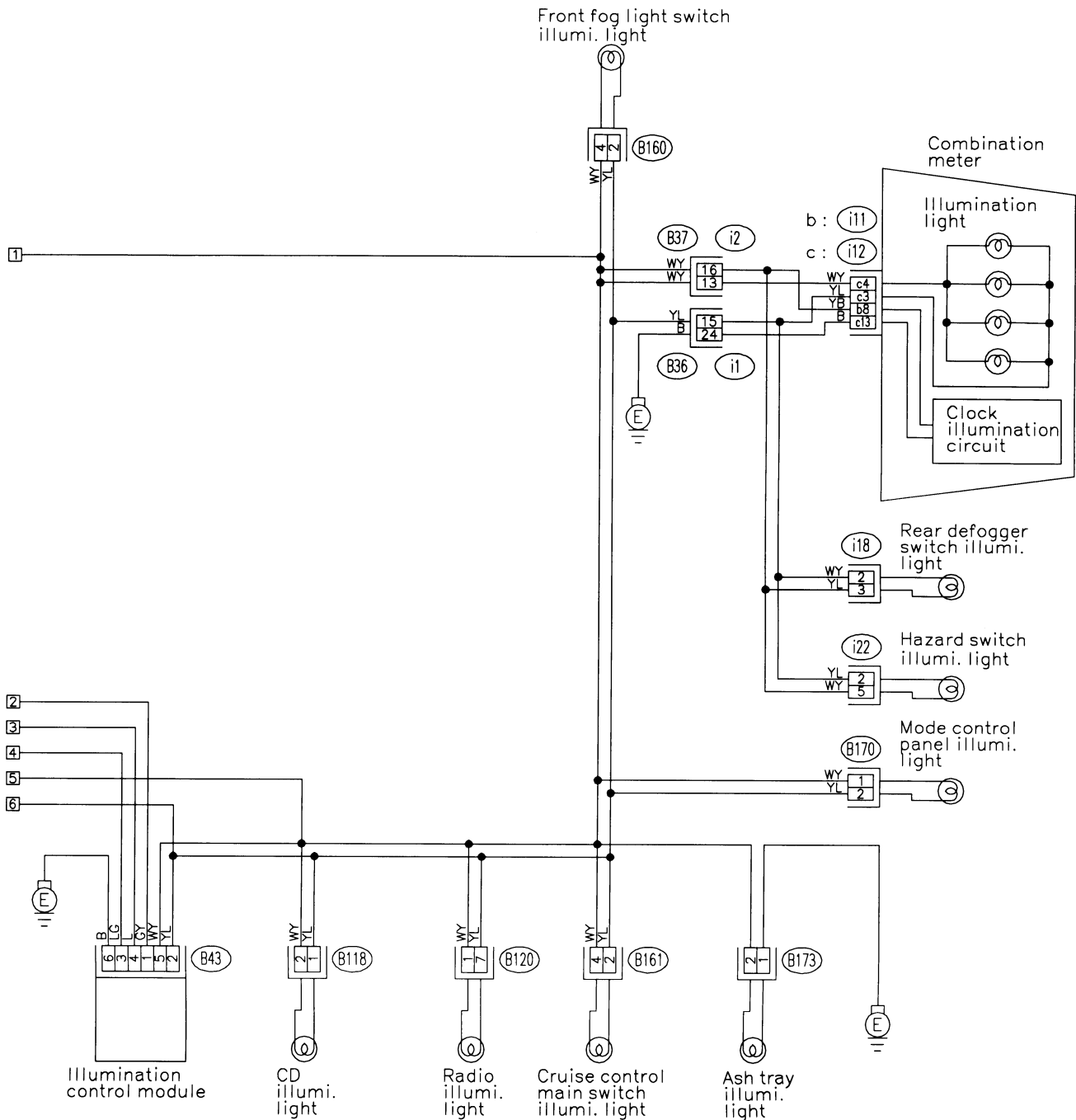

GU21-06B

# WIRING DIAGRAM

[D5Q1] **6-3**  
5. Wiring Diagram

## Q: LIGHTING SYSTEM (FRONT FOG LIGHT)

### 1. WITHOUT DAYTIME RUNNING LIGHT MODEL

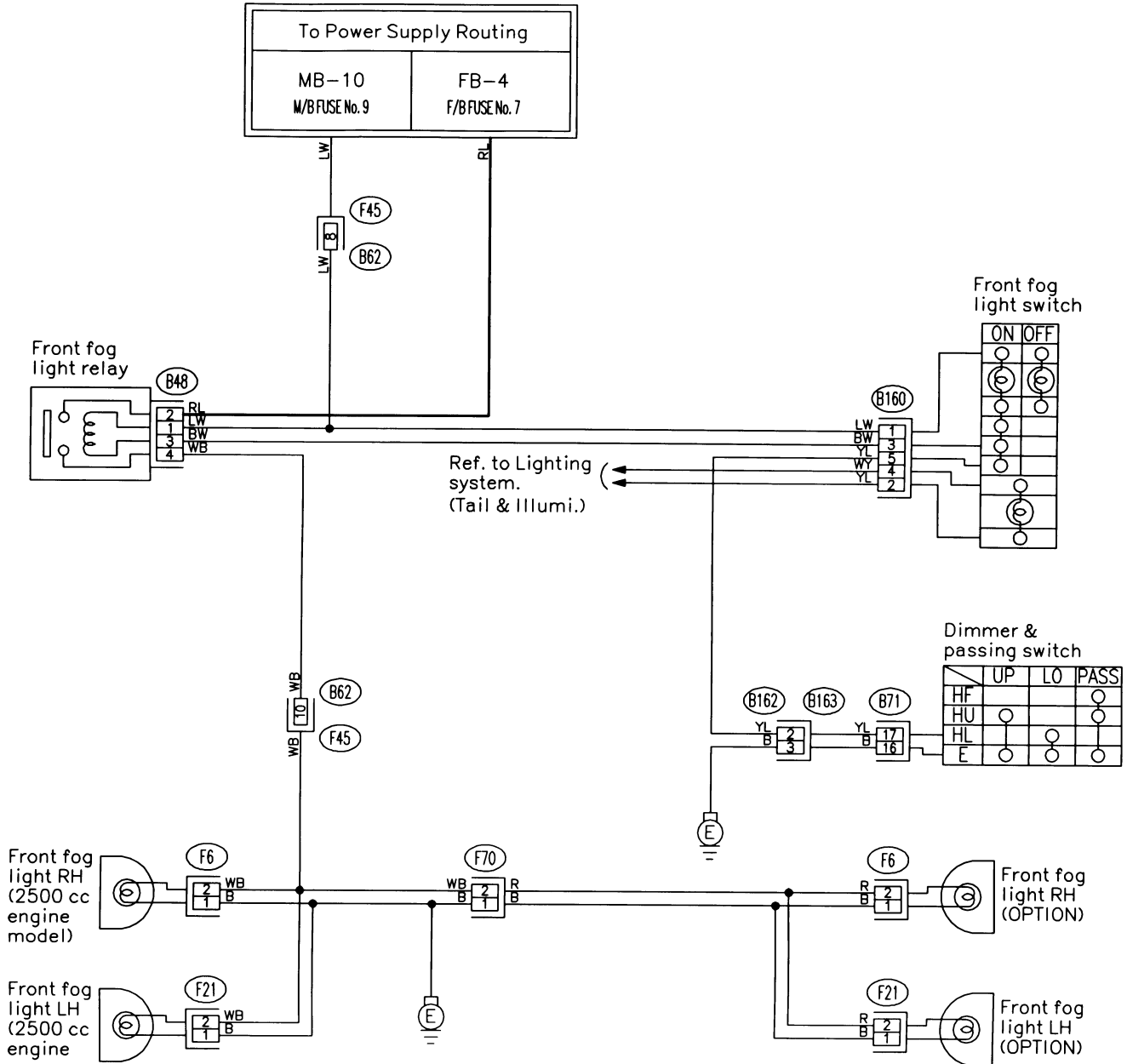

model)

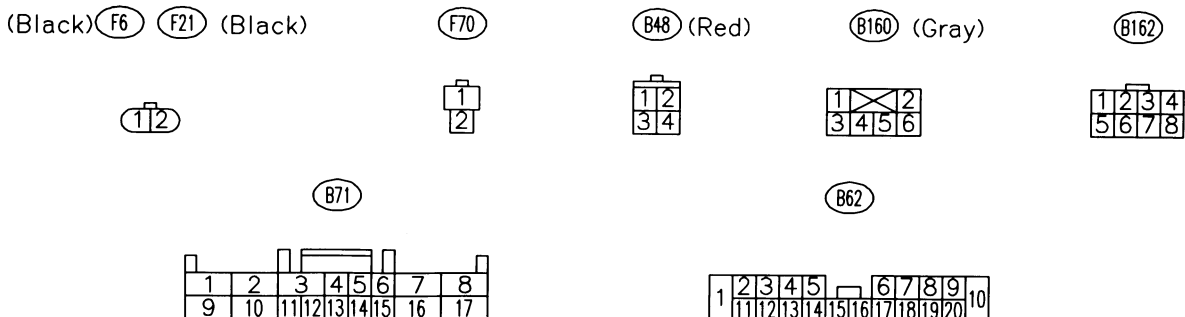

GU22-04



# WIRING DIAGRAM

## 2. WITH DAYTIME RUNNING LIGHT MODEL

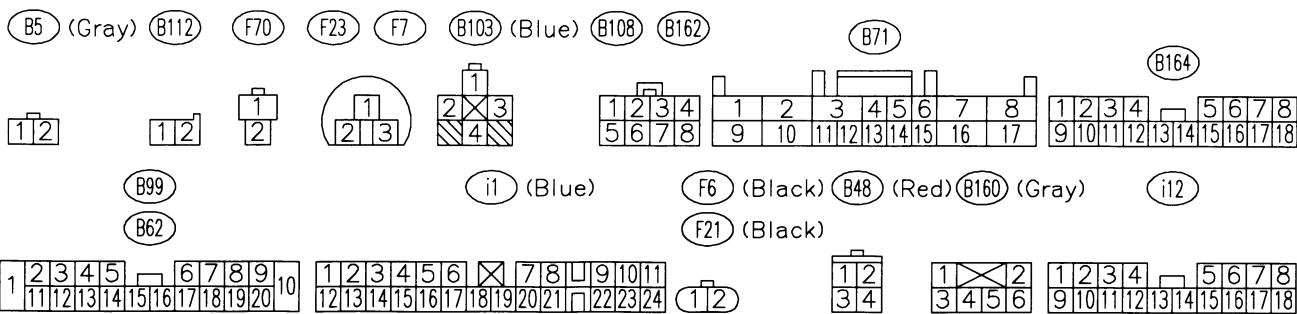
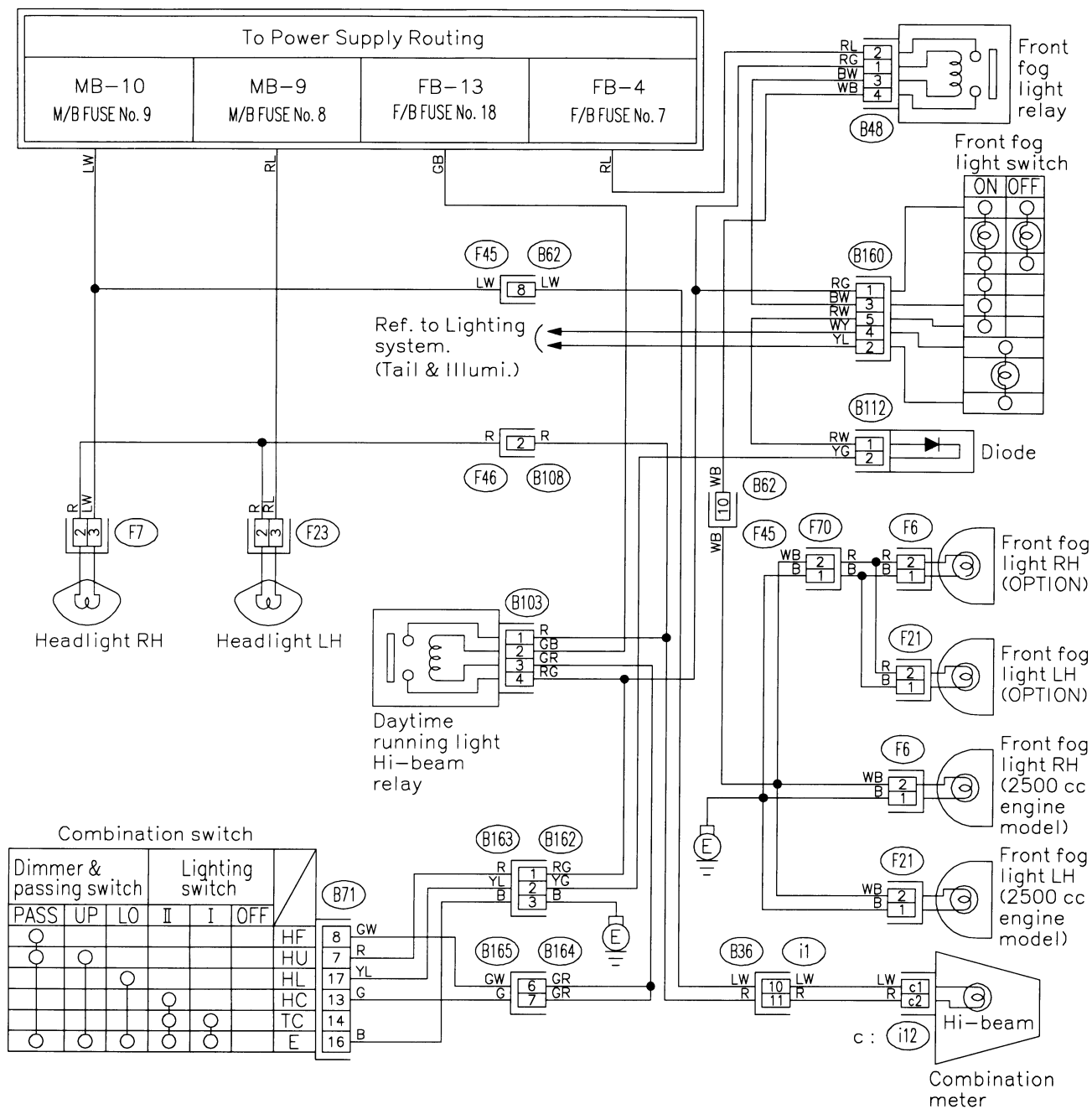

# WIRING DIAGRAM

[D5R1] **6-3**  
5. Wiring Diagram

## R: LIGHTING SYSTEM (HEADLIGHT)

### 1. WITHOUT DAYTIME RUNNING LIGHT MODEL

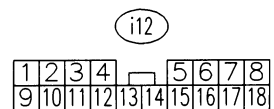
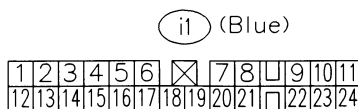
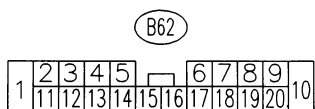
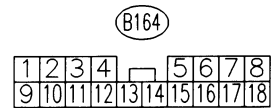
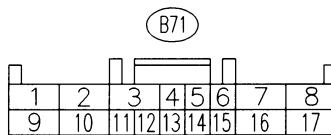
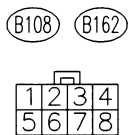
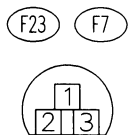
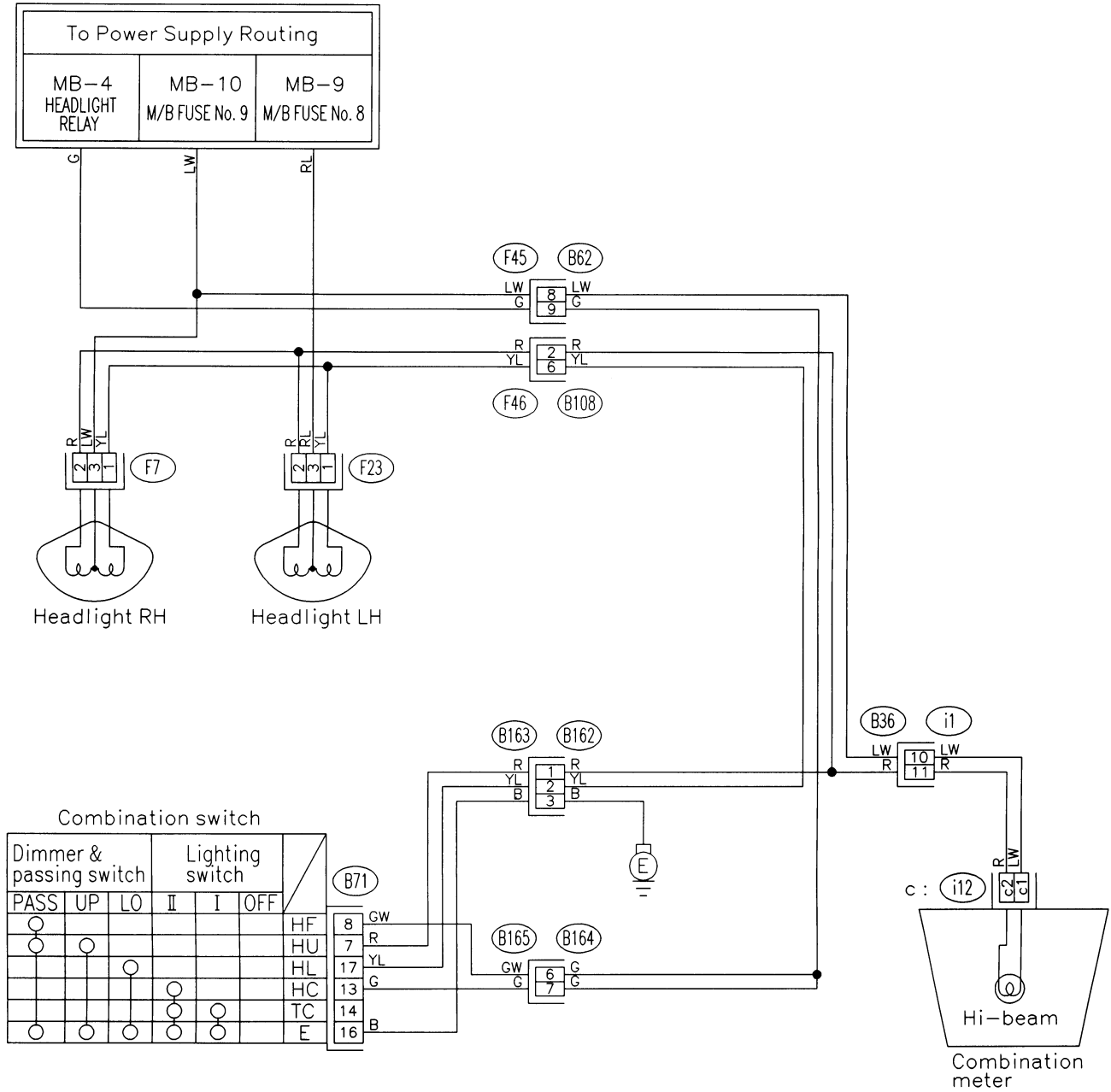

# WIRING DIAGRAM

## 2. WITH DAYTIME RUNNING LIGHT MODEL

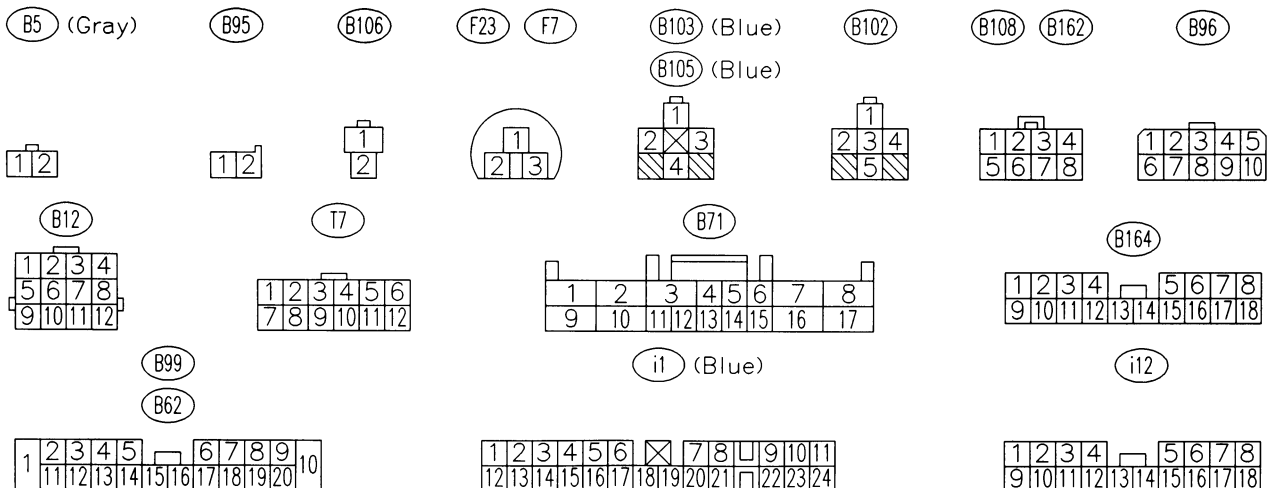
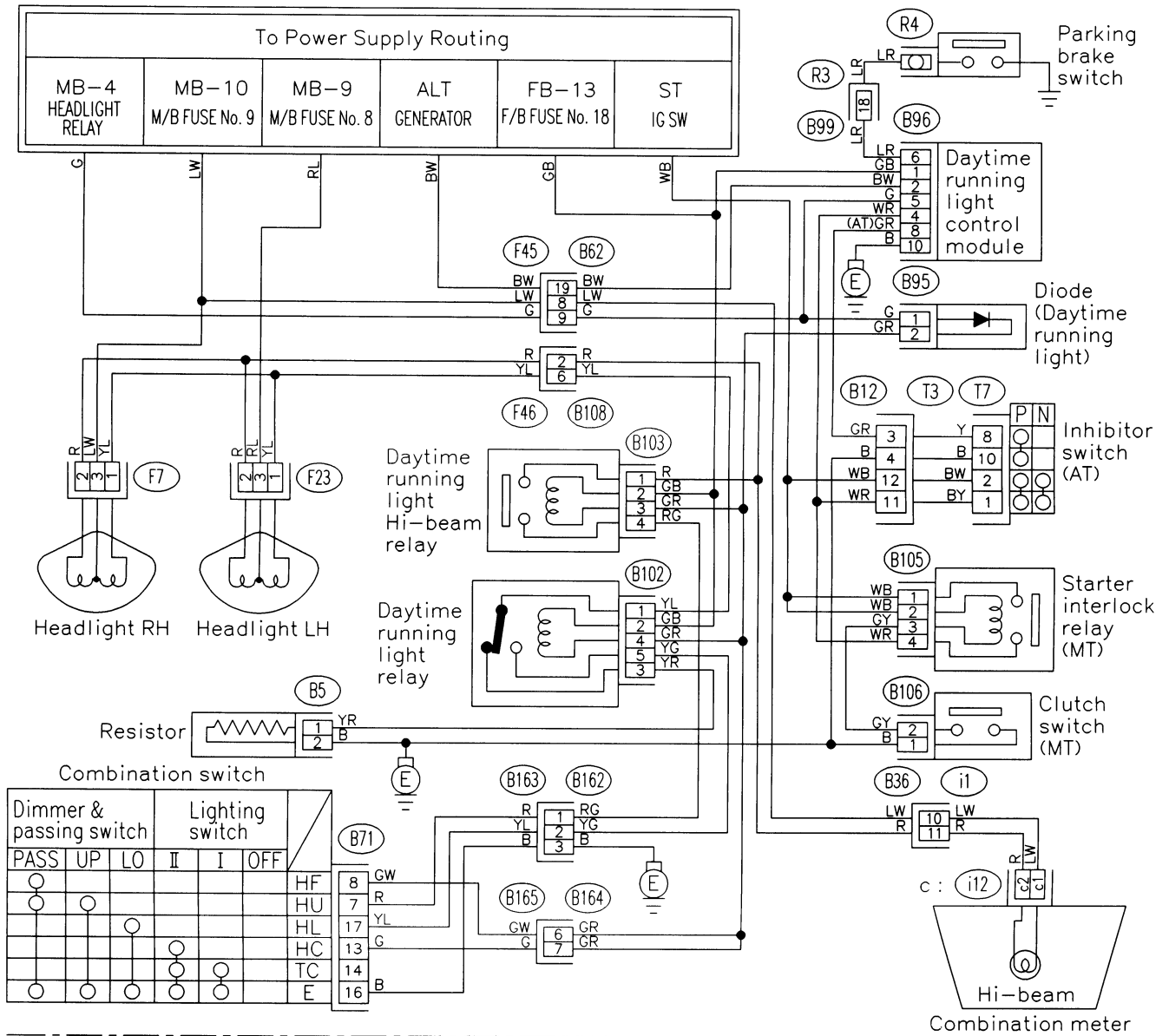

# WIRING DIAGRAM

[D5S0] **6-3**  
5. Wiring Diagram

## S: LIGHTING SYSTEM (IN COMPARTMENT)

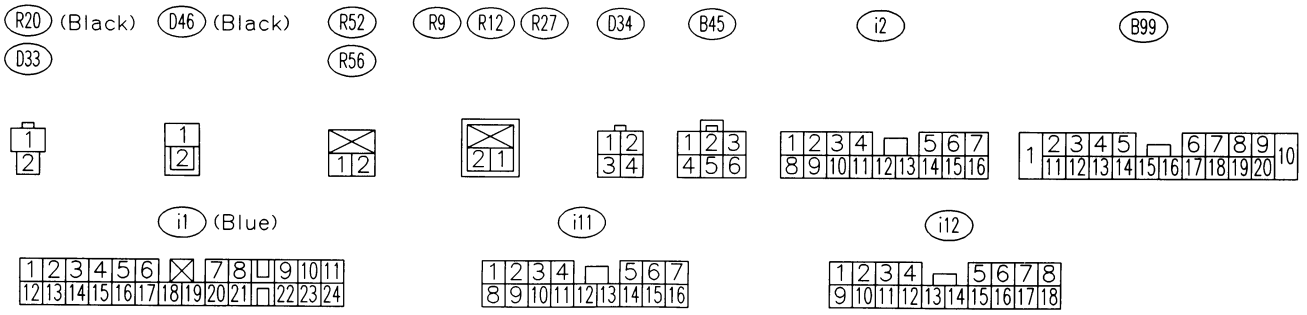
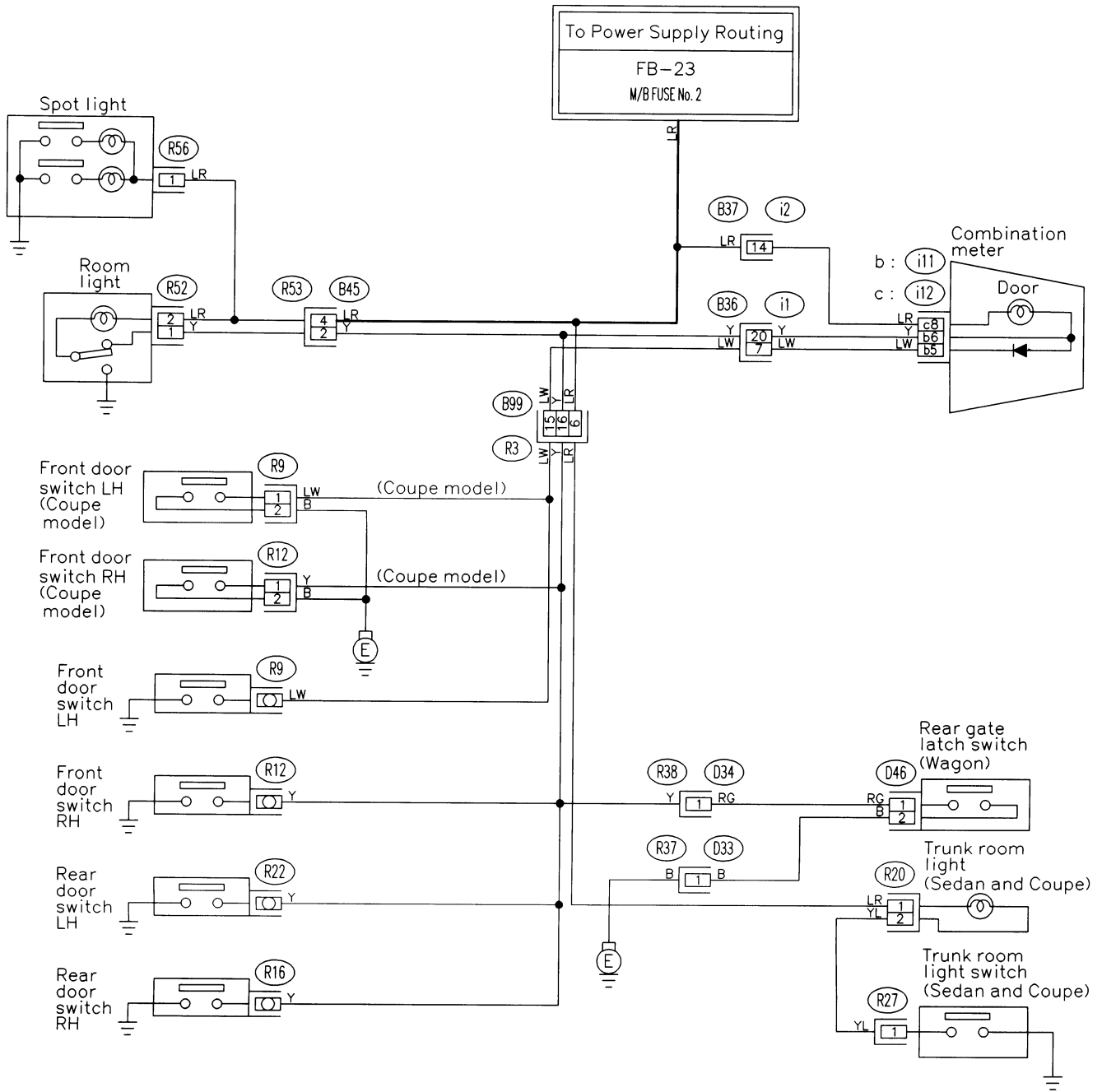

T: LIGHTING SYSTEM (STOP LIGHT)

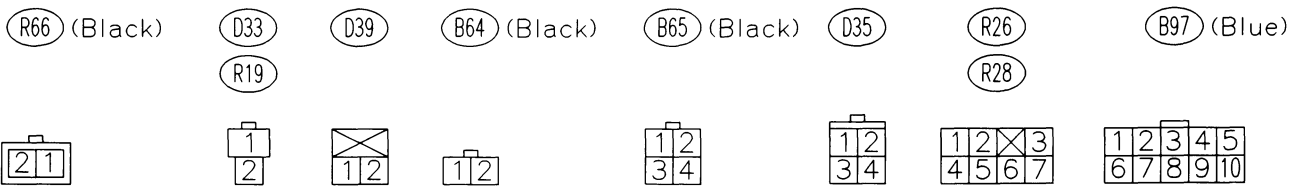
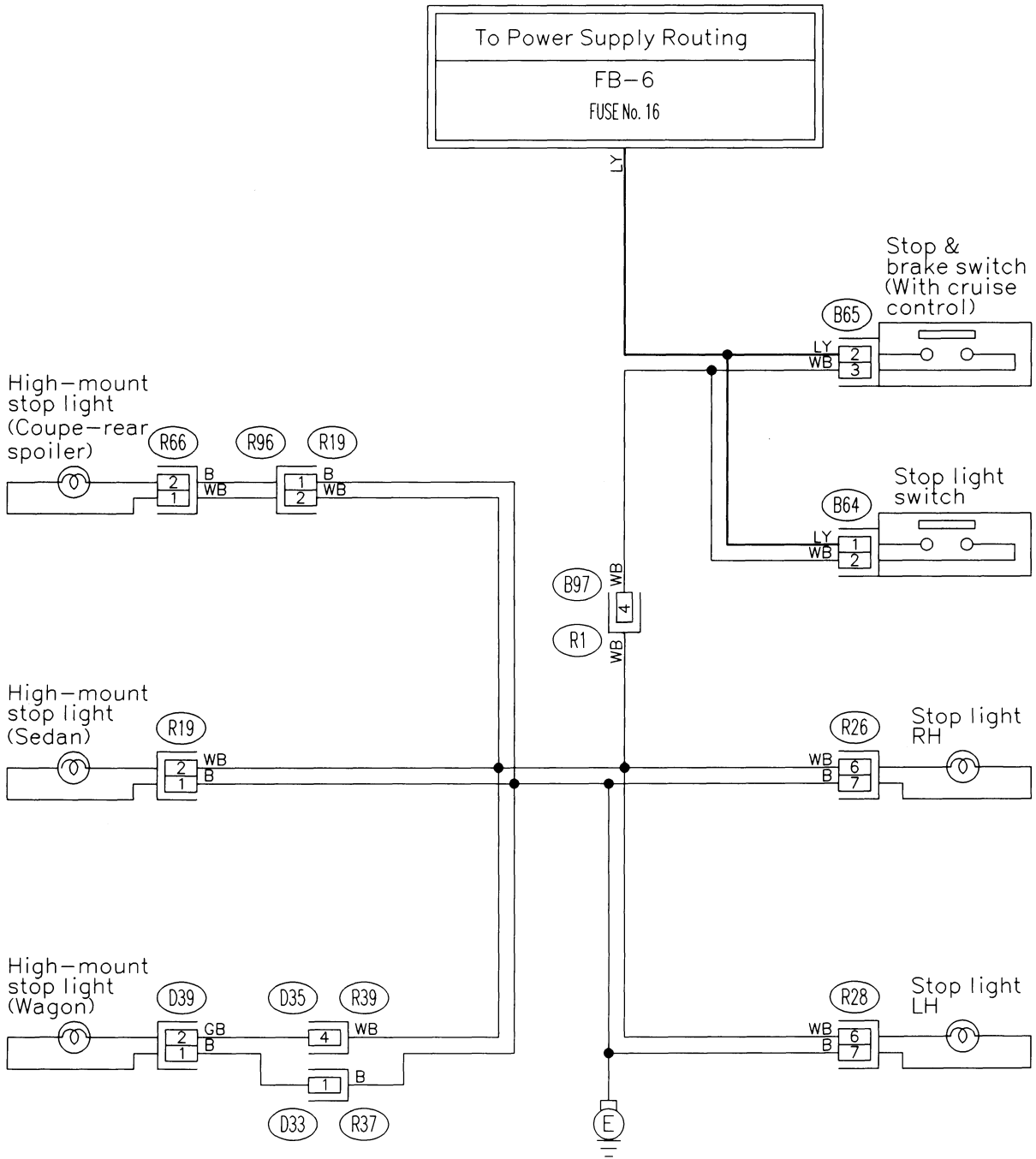

# WIRING DIAGRAM

[D5U0] **6-3**  
5. Wiring Diagram

## U: LIGHTING SYSTEM (TURN SIGNAL LIGHT AND HAZARD LIGHT)

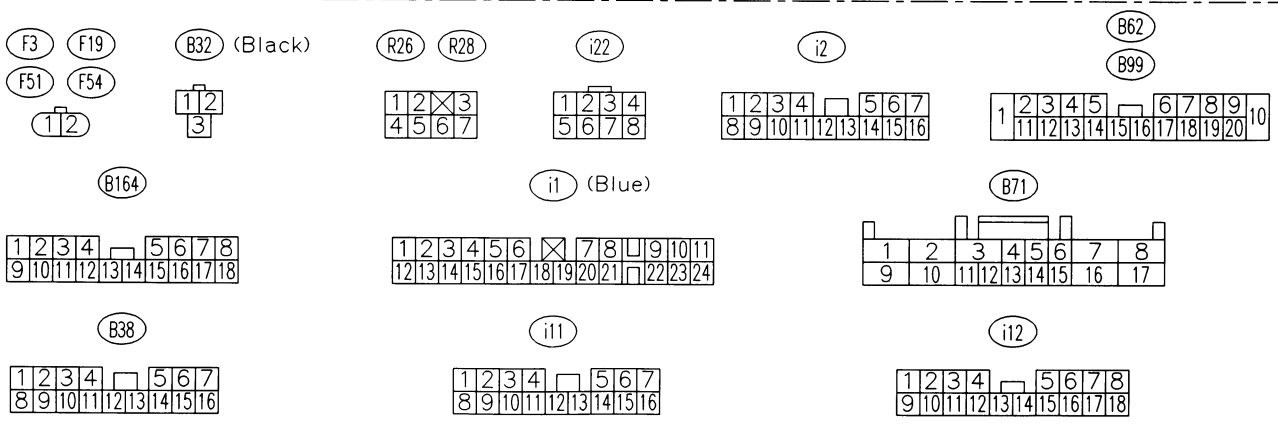
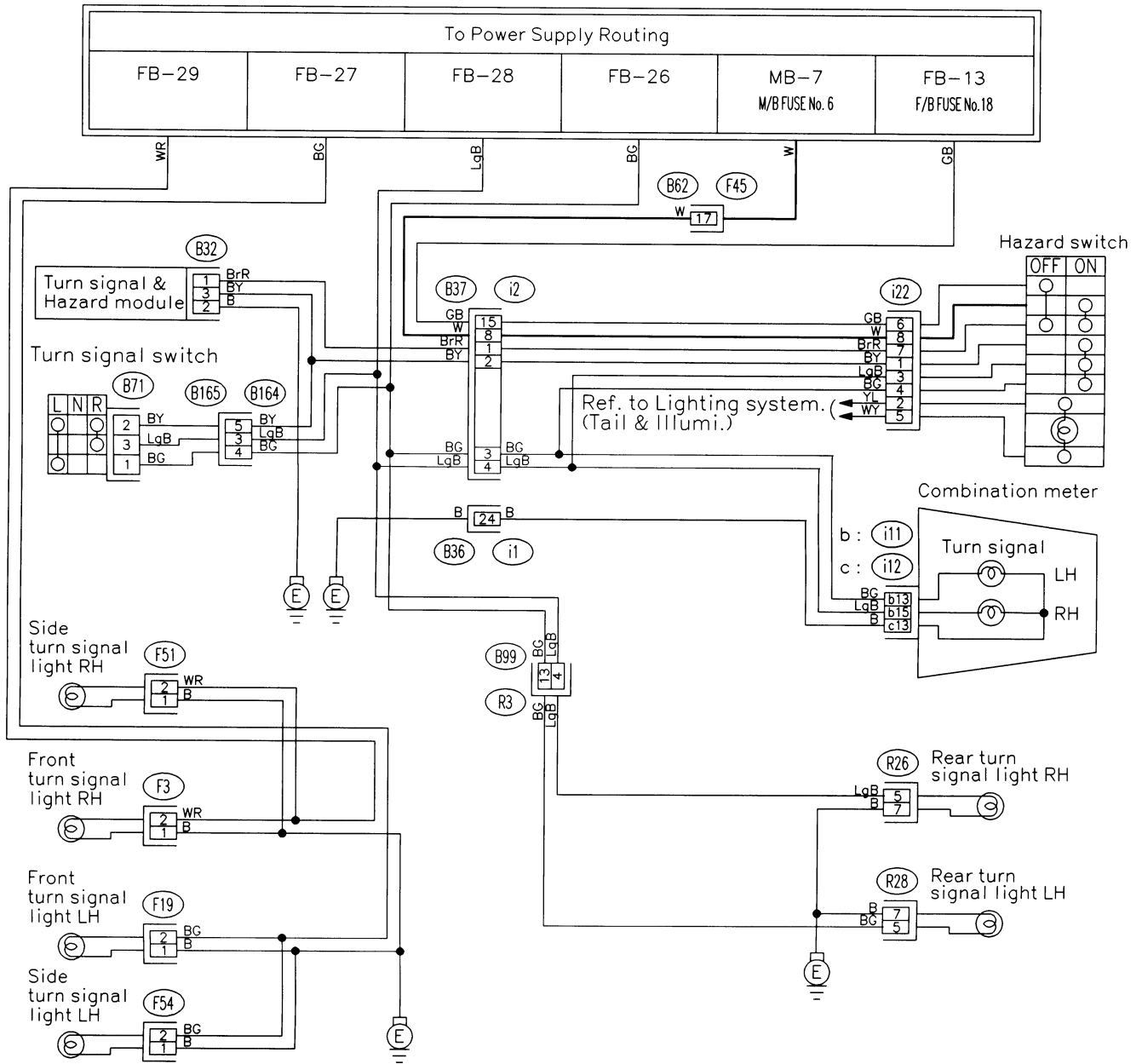

GU26-04

V: OIL PRESSURE AND TEMPERATURE GAUGE SYSTEM

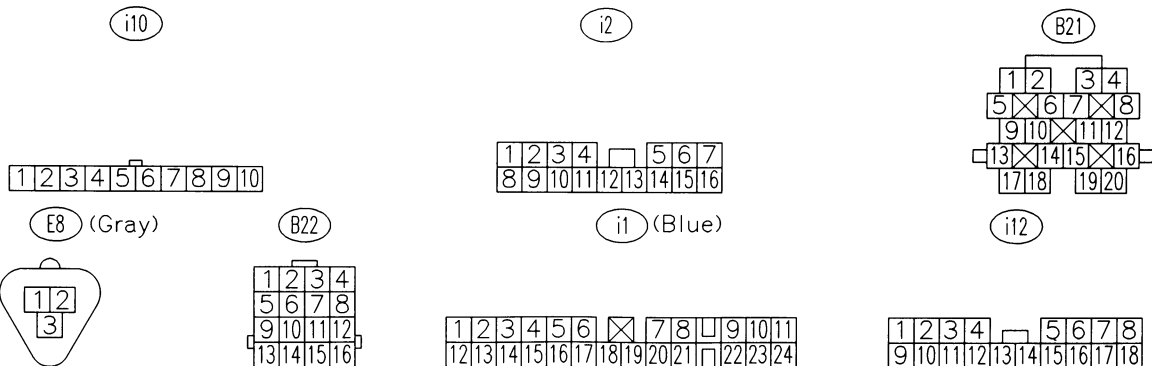
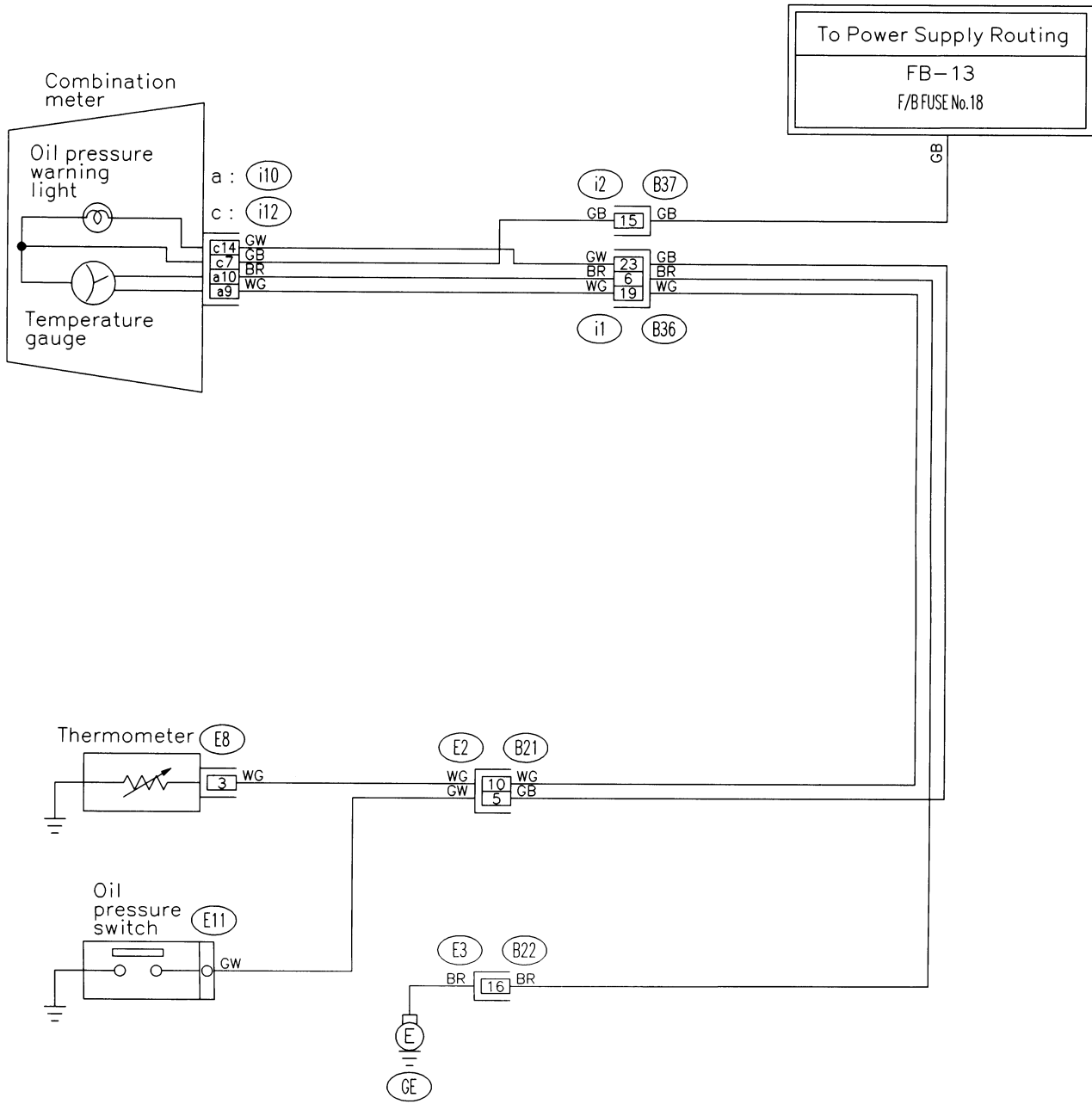

W: PARKING BRAKE AND BRAKE FLUID LEVEL WARNING SYSTEM

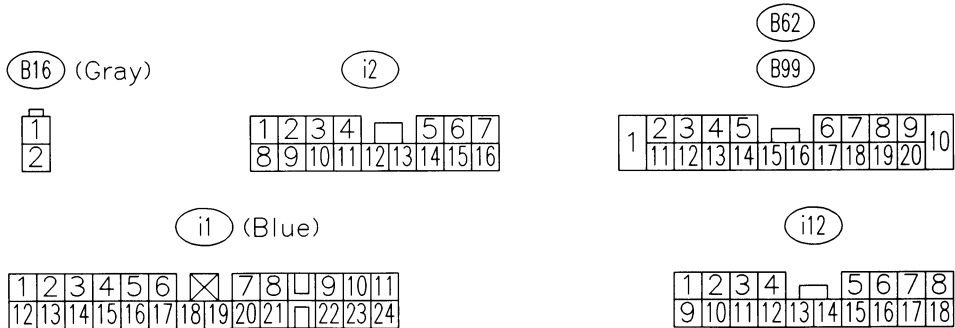
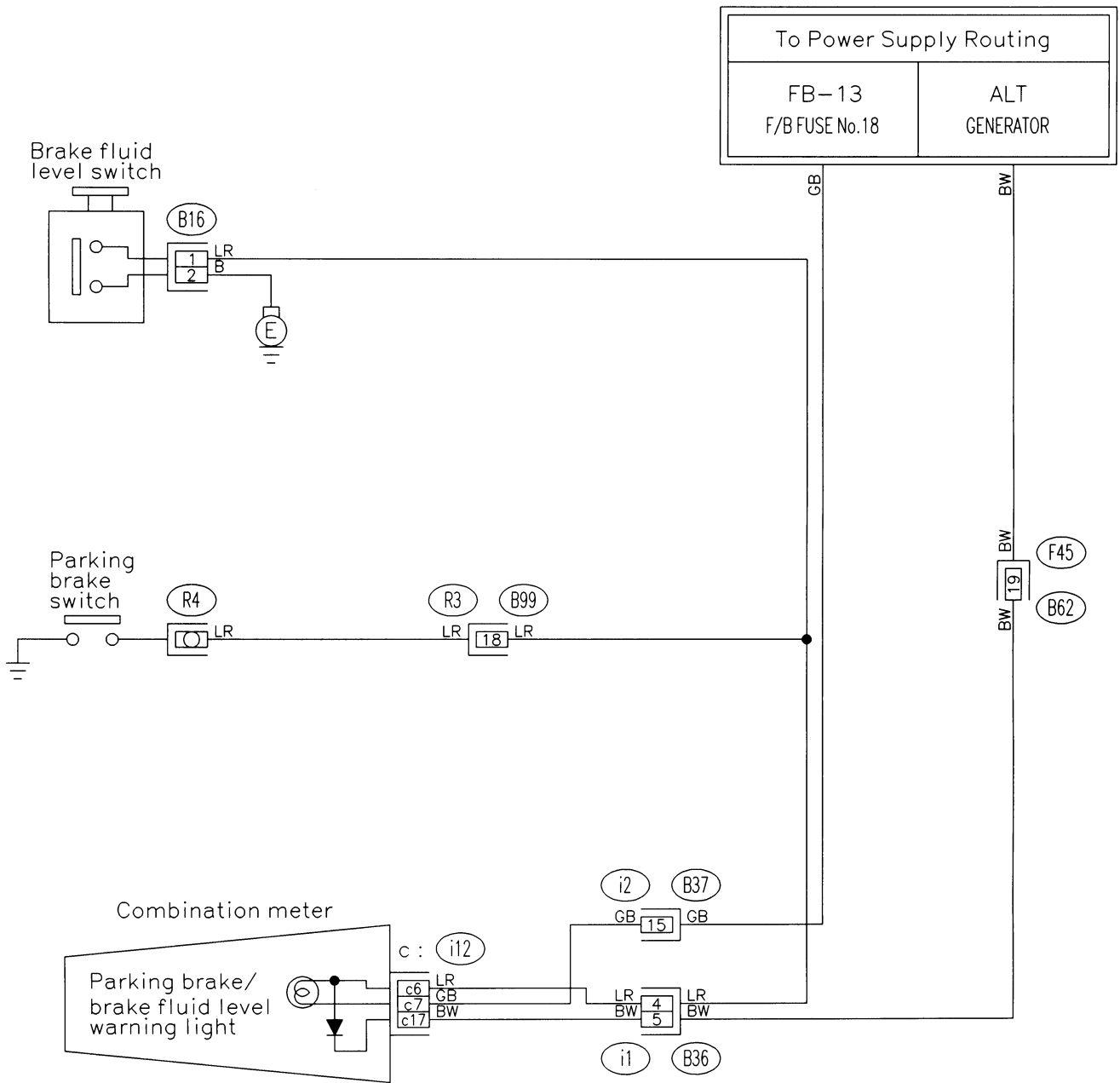

GU60-05



X: POWER WINDOW SYSTEM

1. COUPE MODEL

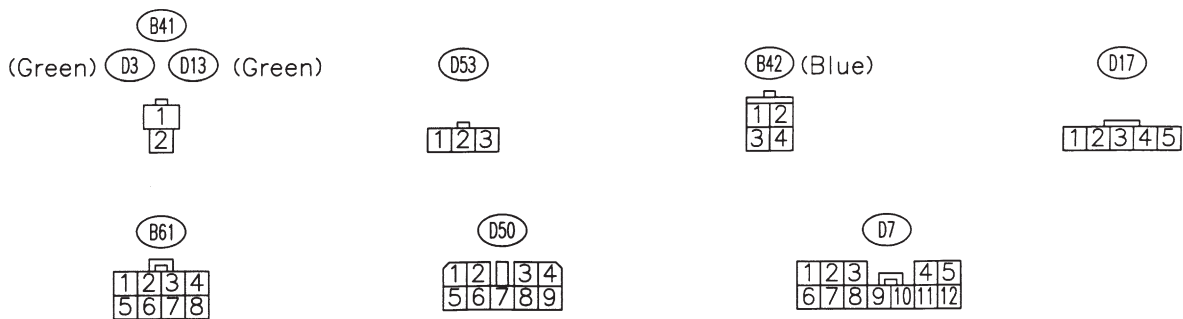
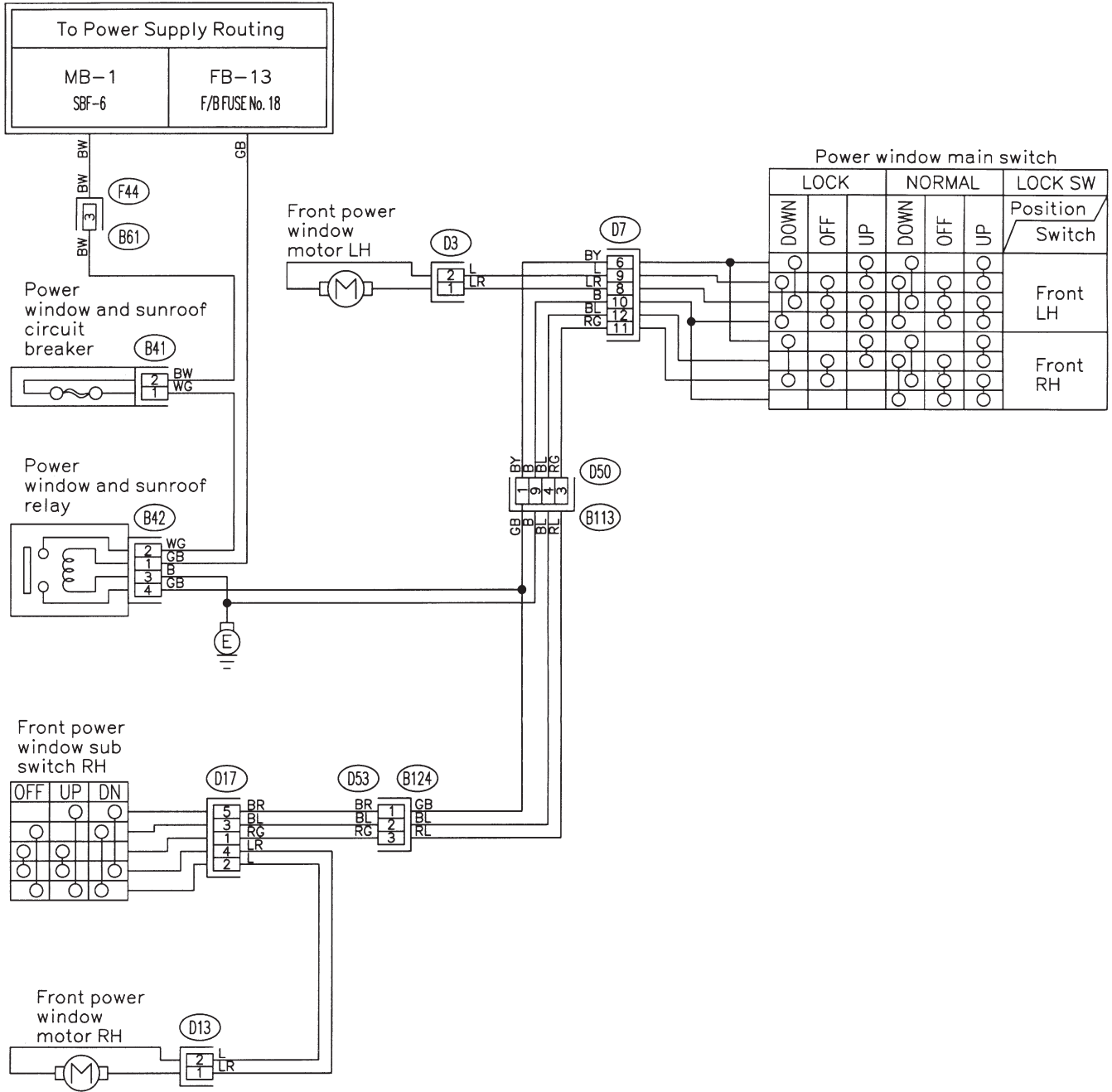

# WIRING DIAGRAM

## 2. SEDAN AND WAGON MODEL

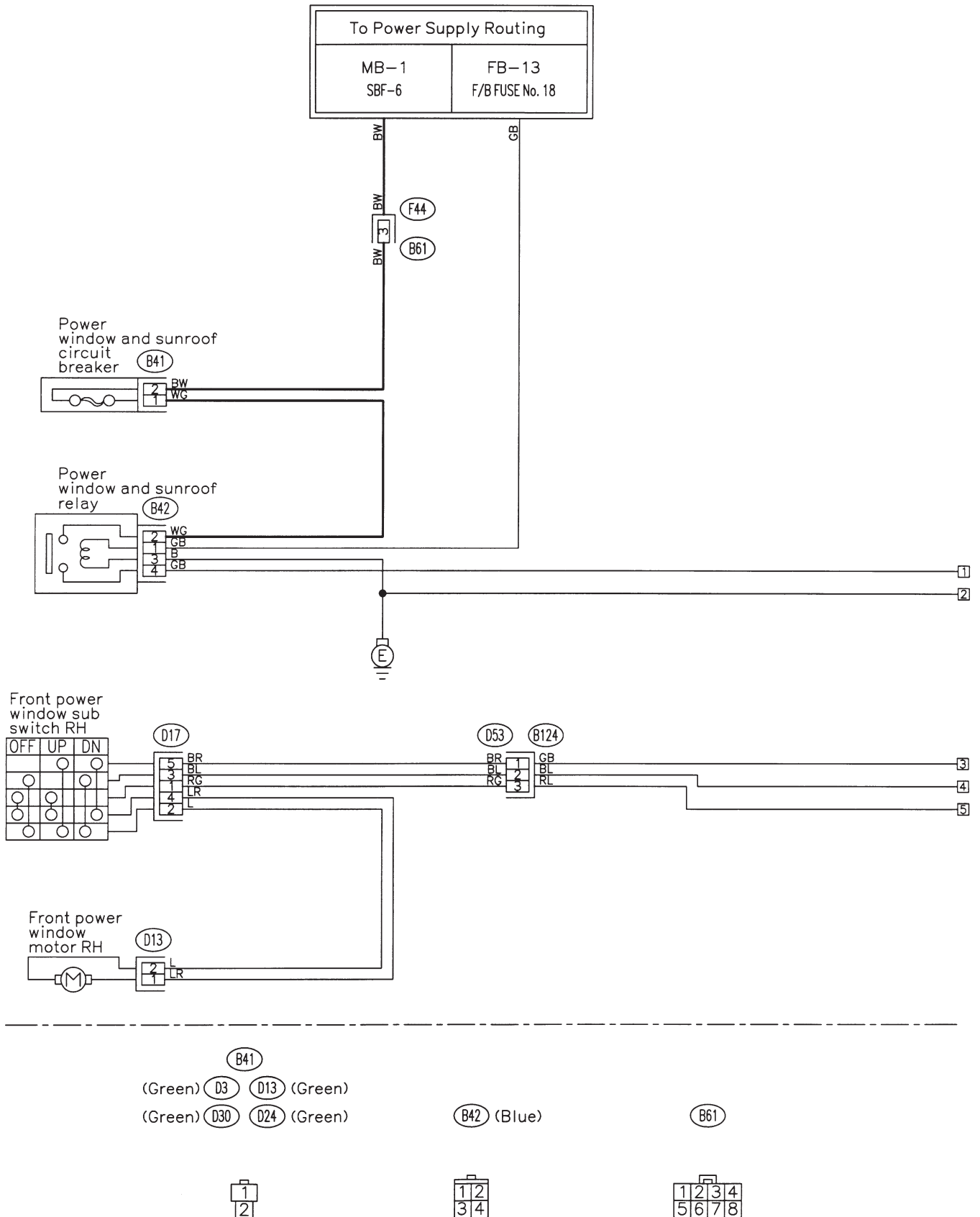

**6-3 [D5X2]**  
5. Wiring Diagram

**WIRING DIAGRAM**

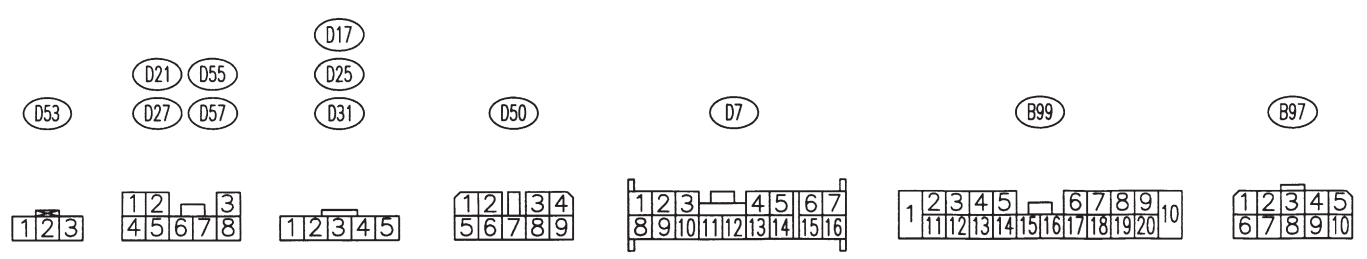
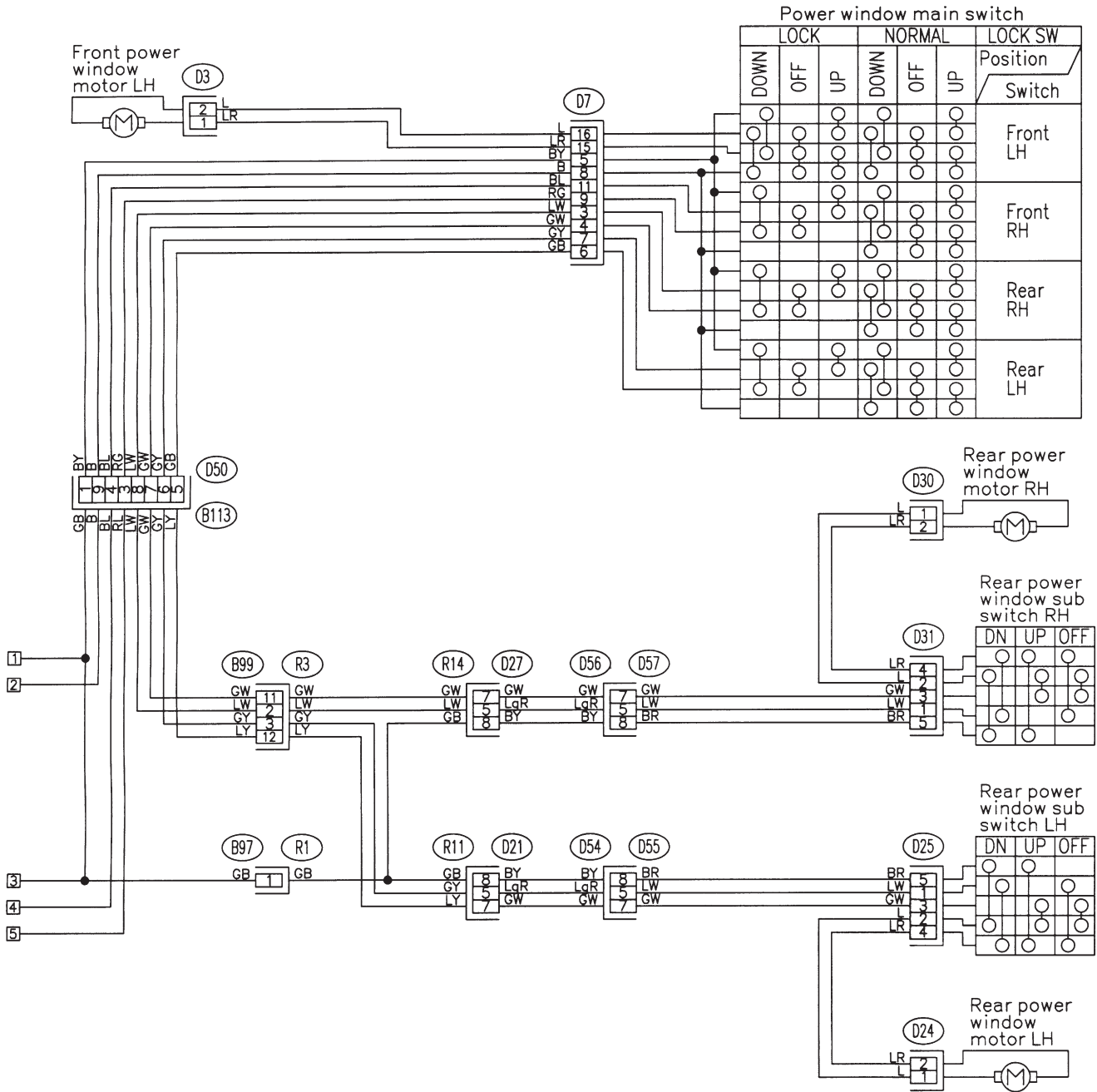

GU70-03B

## Y: RADIATOR FAN SYSTEM

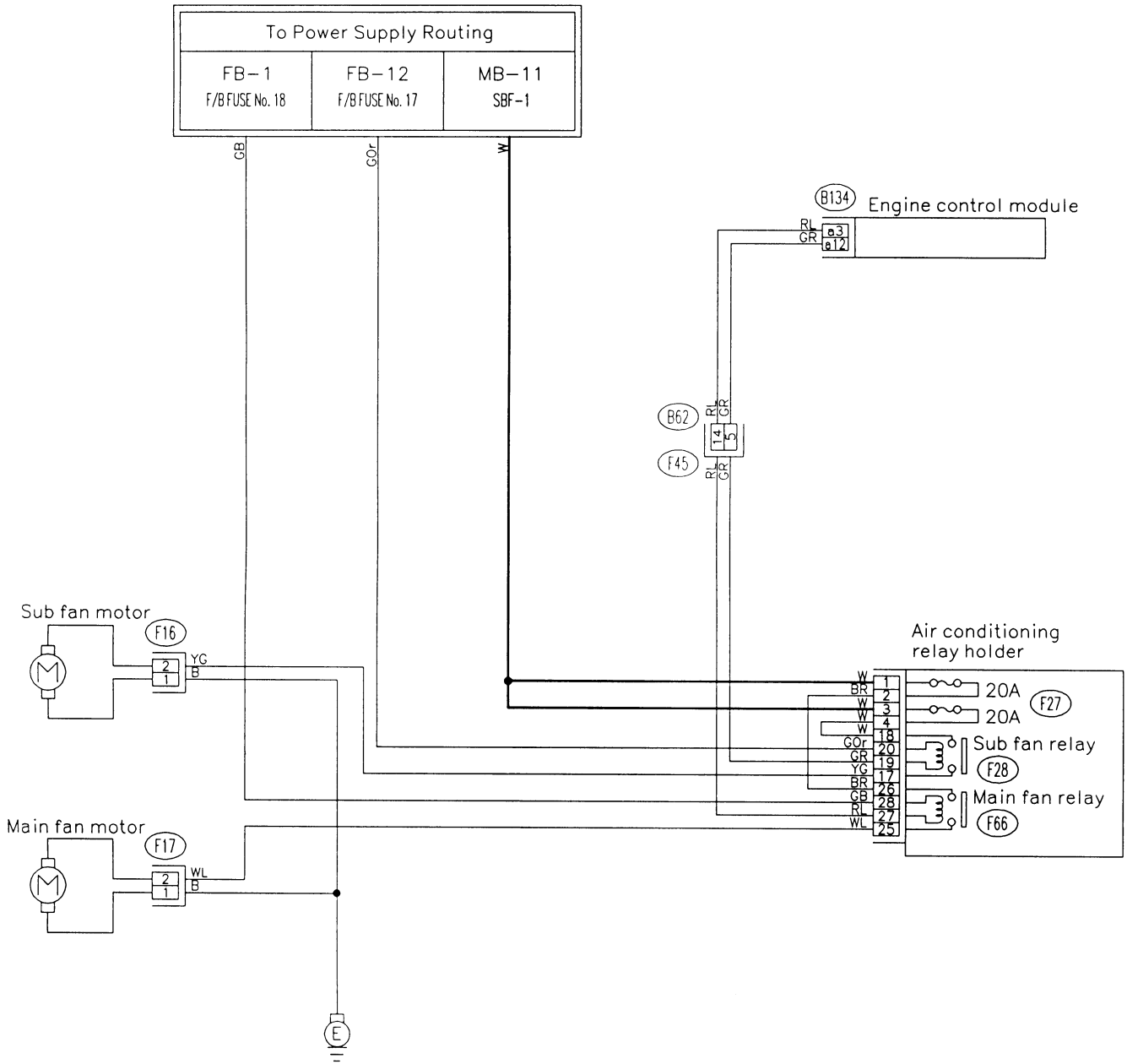

(F16) (Black)  
(F17) (Black)



(B62)

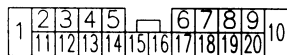

(F27) (F31) (F28) (F66) (F67)

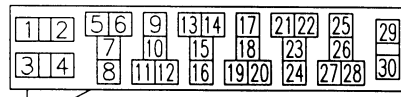

a: (B134)

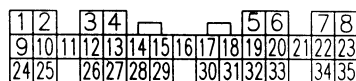

Z: REAR ACCESSORY POWER SUPPLY SYSTEM

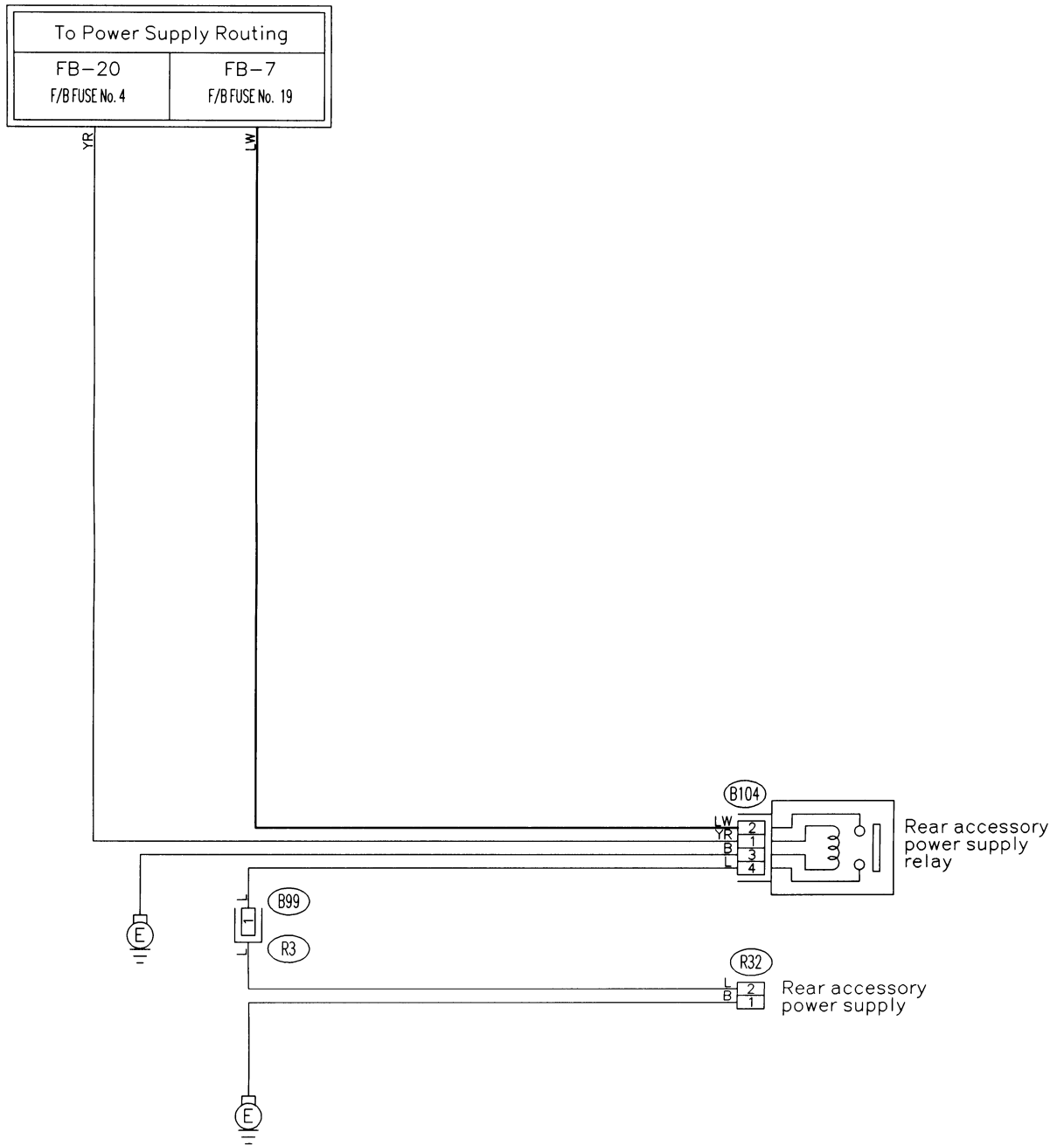

(R32)

(B99)

(B104) (Red)

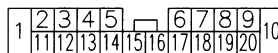

## AA: REAR WINDOW DEFOGGER SYSTEM

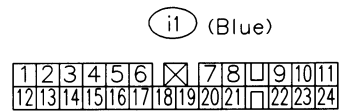
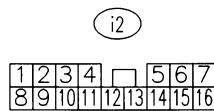
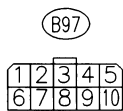
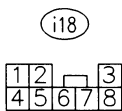
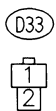
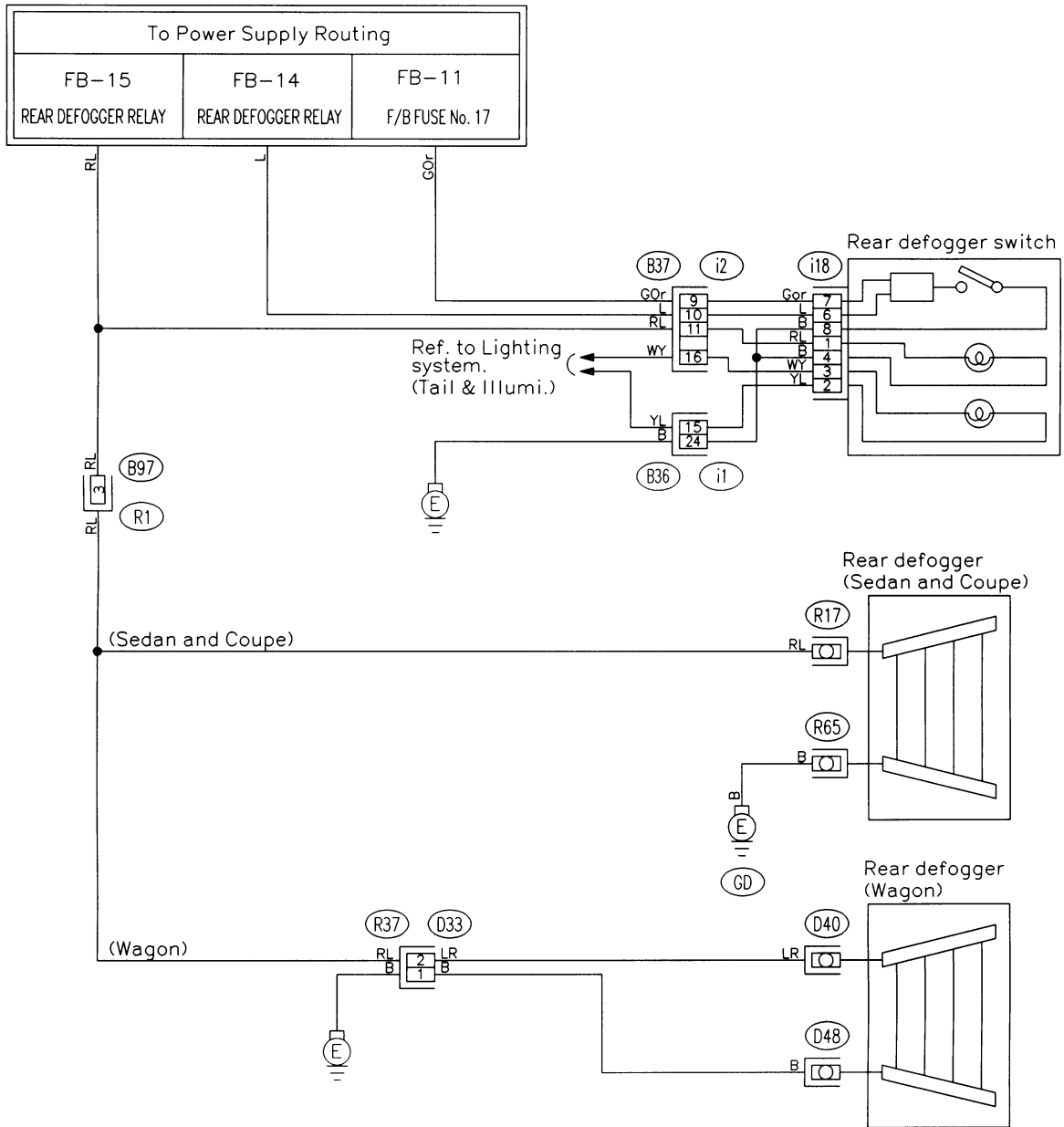

# WIRING DIAGRAM

## AB: REMOTE CONTROLLED REARVIEW MIRROR SYSTEM

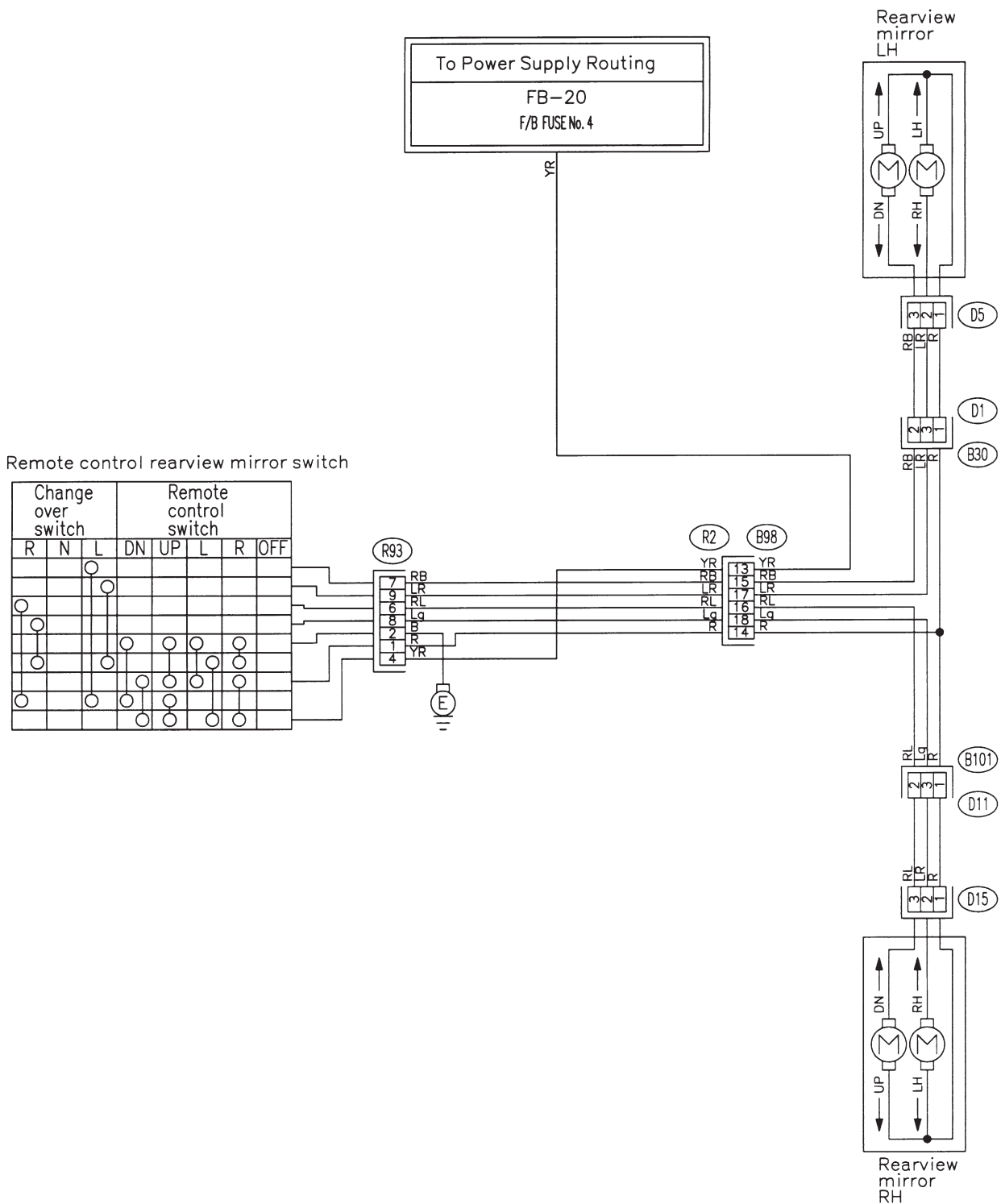

D5  
D15

1	2	3
4	5	6

R93

1	2	3	4	5
6	7	8	9	10

D1  
D11

1	2	3		
4	5	6	7	8
9	10	11	12	13

B98 (Black)

1	2	3	4	5	6	7	8	9		
10	11	12	13	14	15	16	17	18	19	20

# WIRING DIAGRAM

## AC: SEAT BELT WARNING AND KEY WARNING SYSTEM

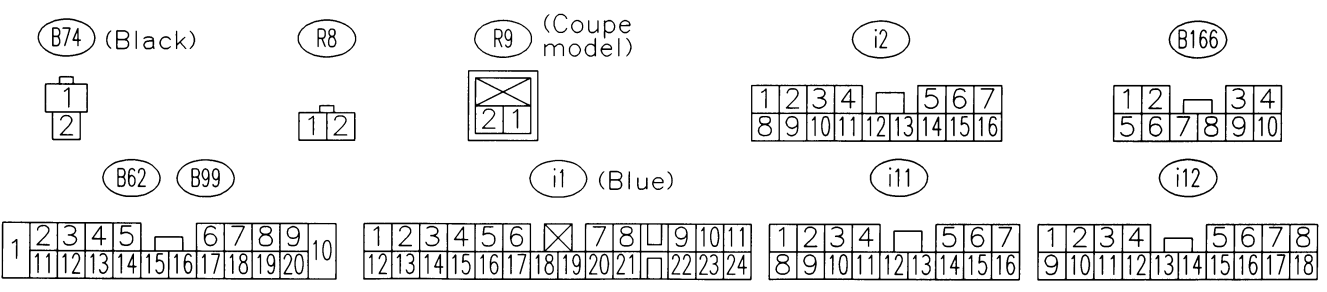
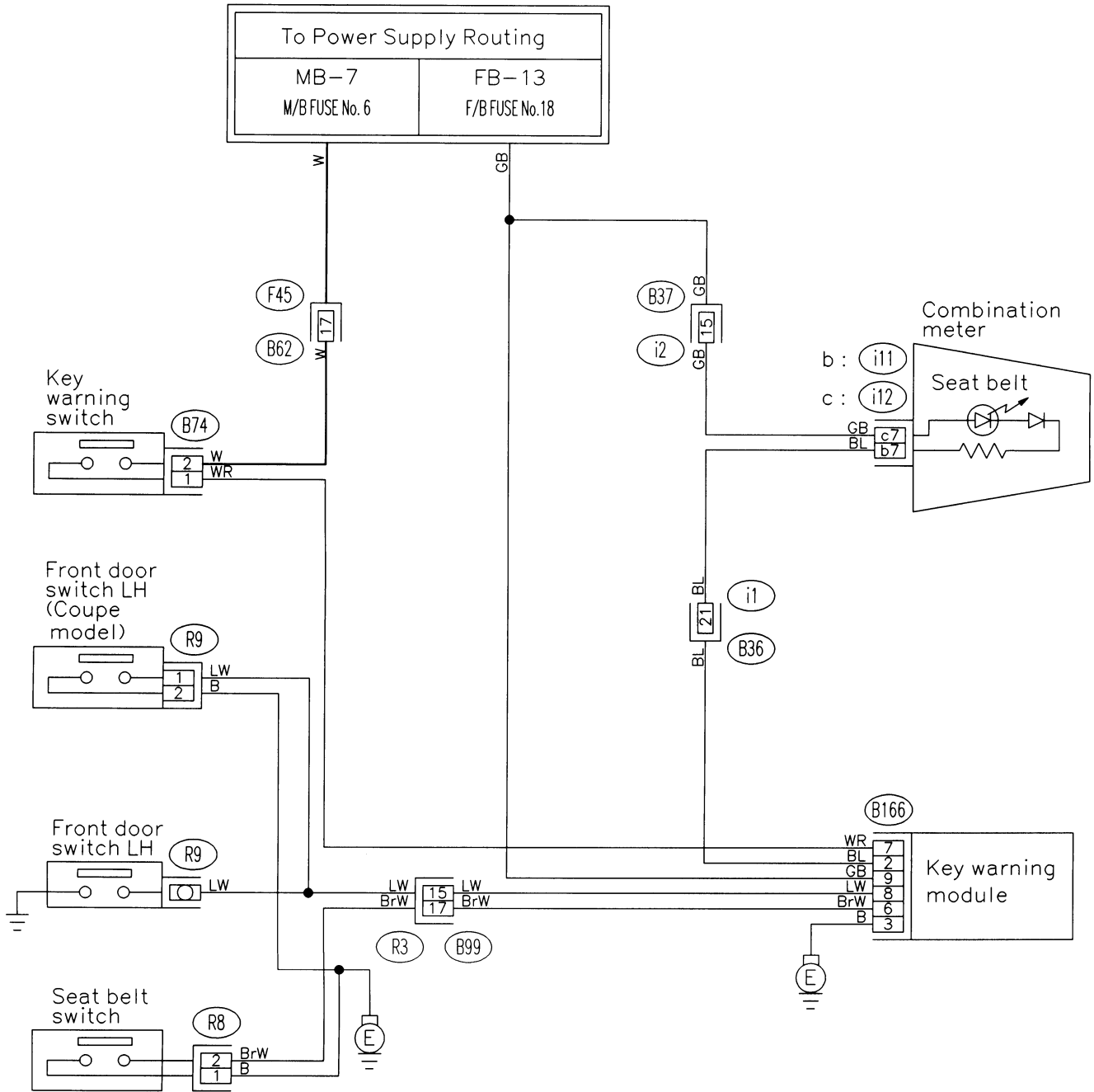



AD: STARTER SYSTEM

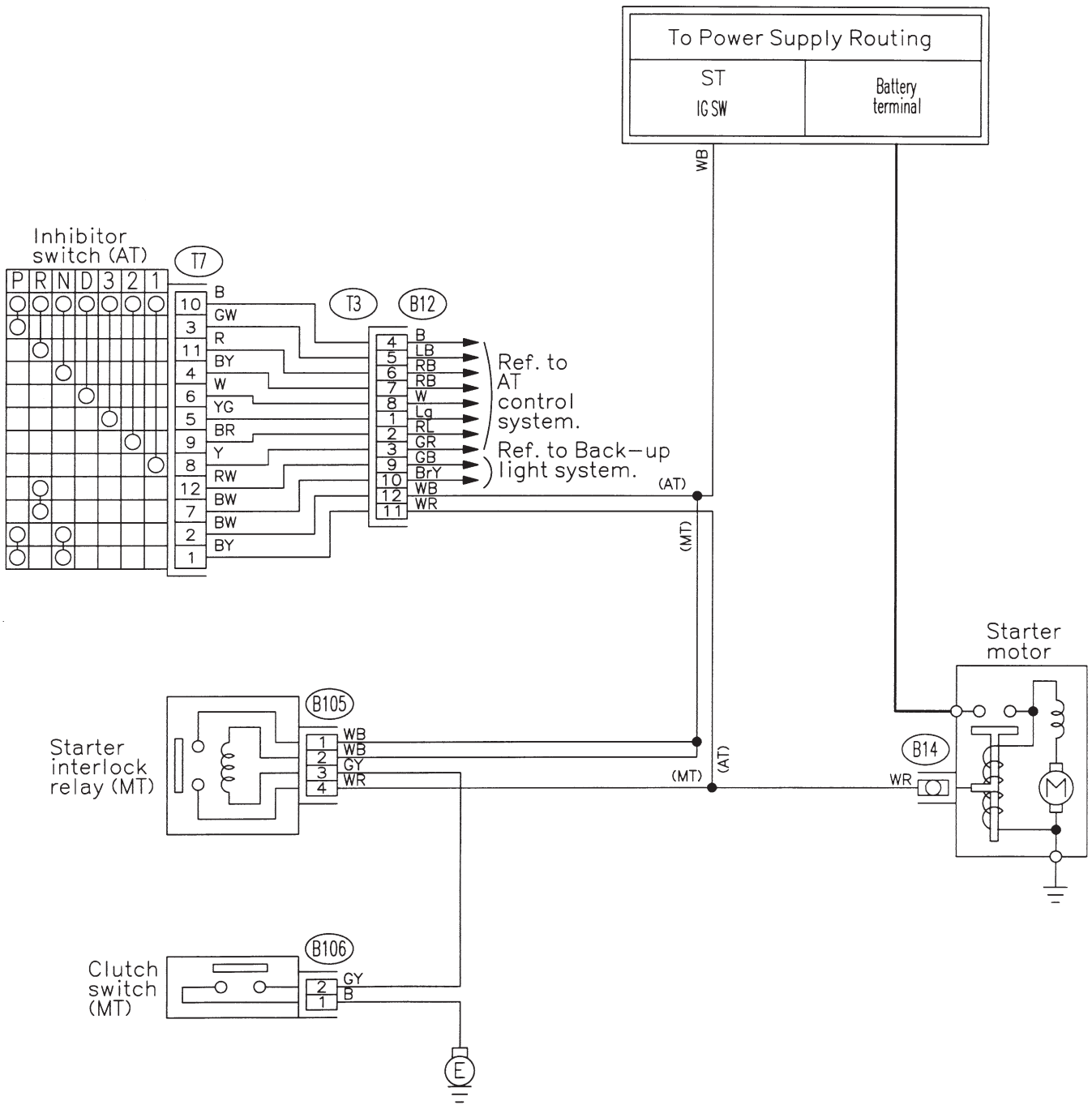

B106



B105 (Blue)



B12

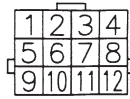

T7

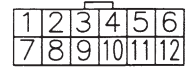

# WIRING DIAGRAM

## AE: SUNROOF SYSTEM

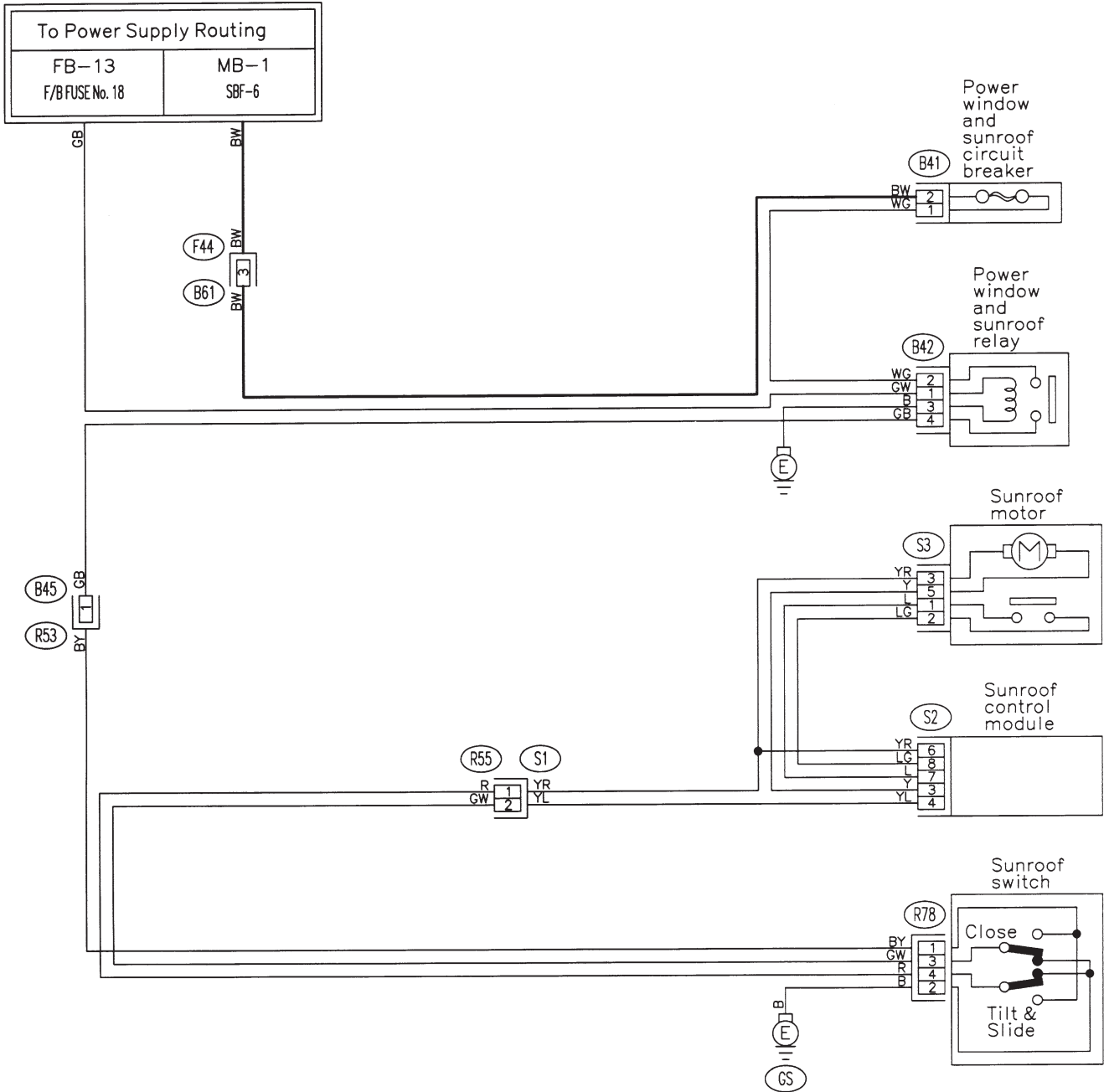

AF: WIPER AND WASHER SYSTEM (FRONT)

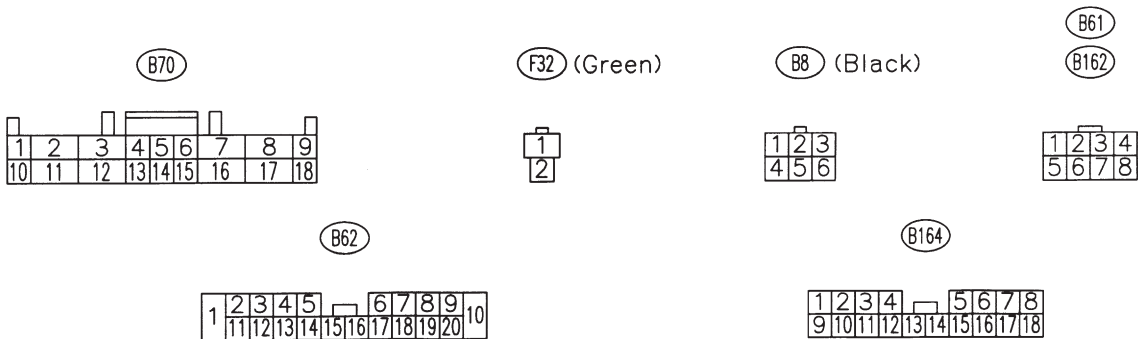
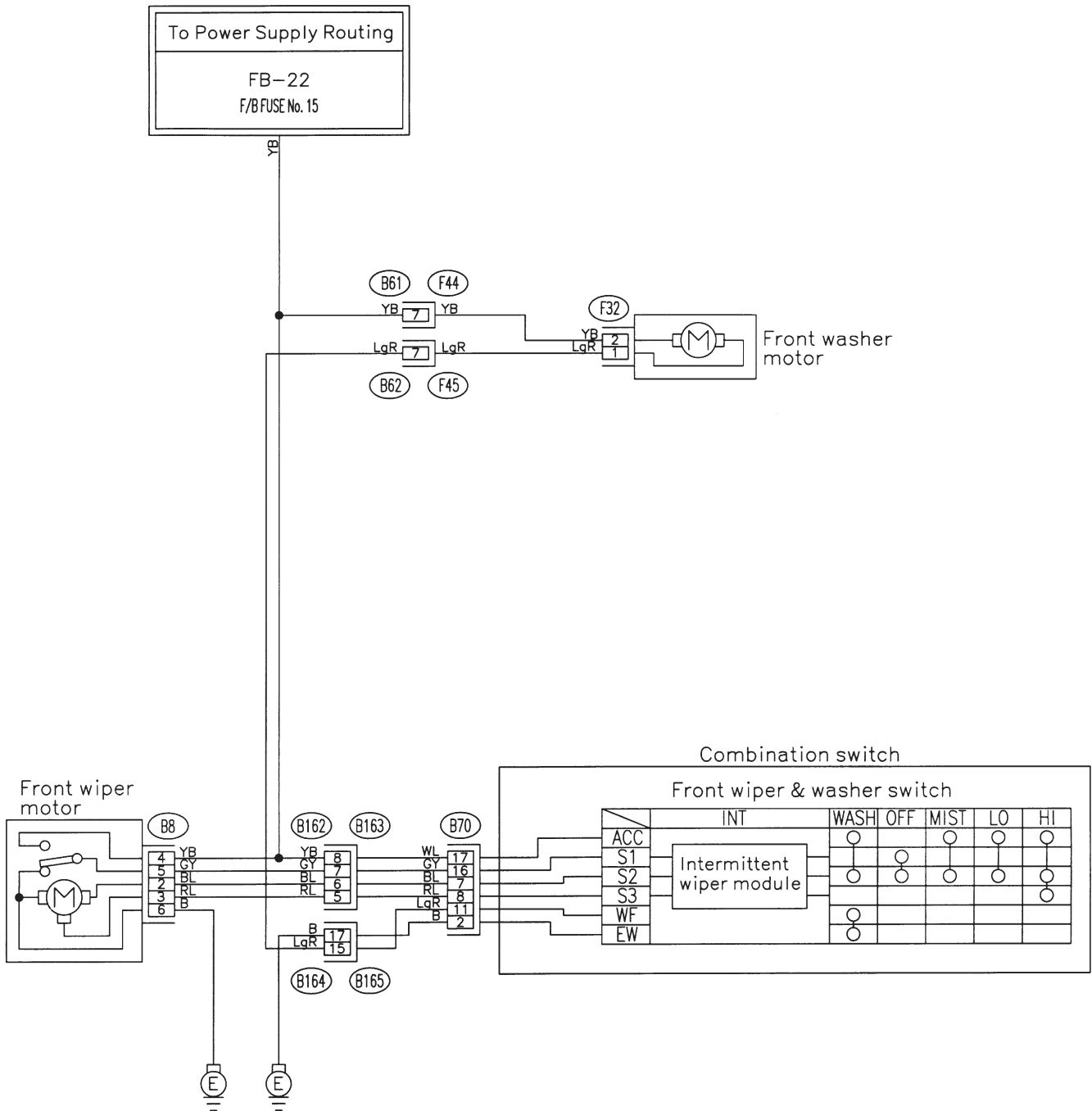

## AG: WIPER AND WASHER SYSTEM (REAR)

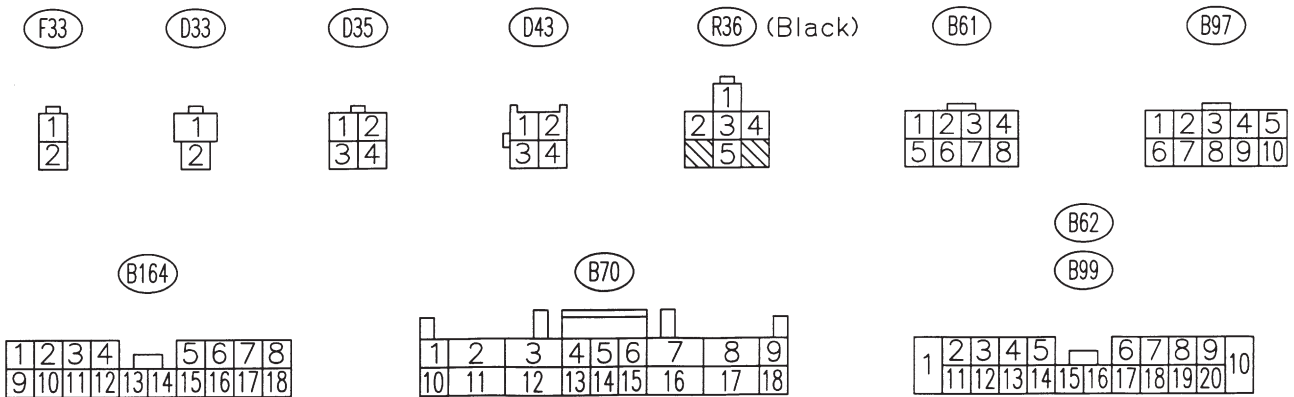
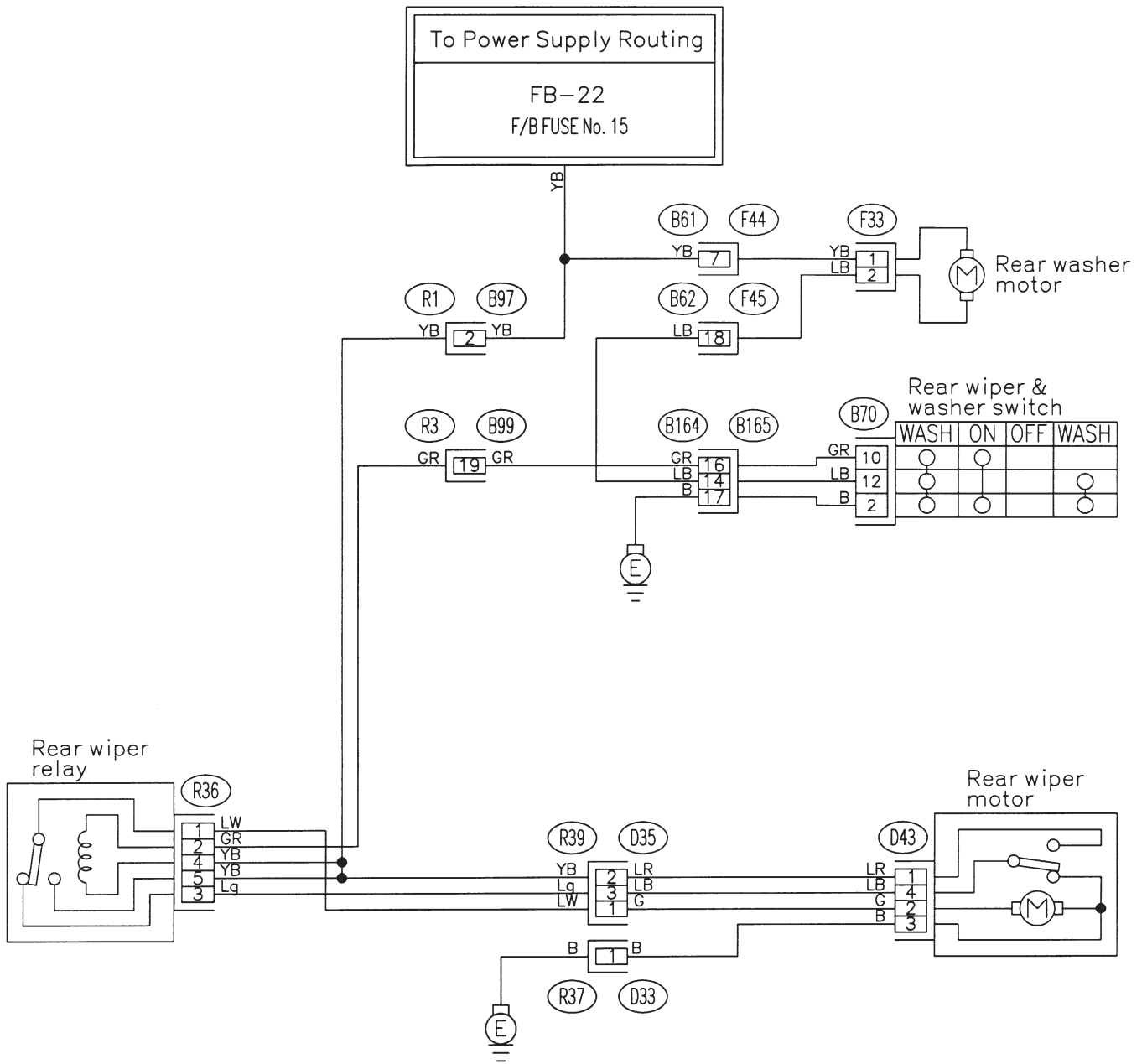

AH: MULTIPLE POWER SUPPLY (OPTION)

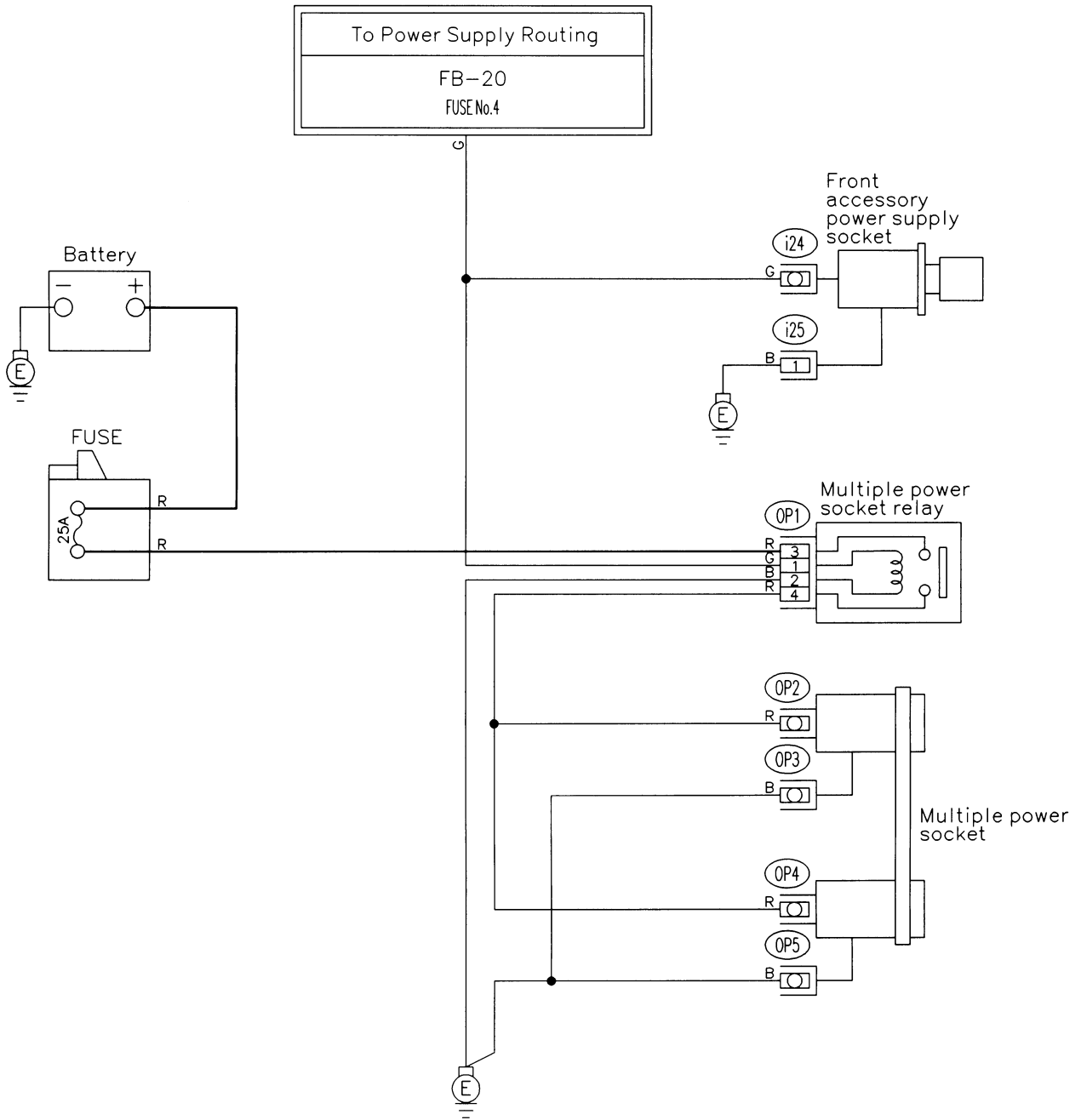

i25

OP1 (Blue)



GU82-01

# WIRING DIAGRAM

[D5A10] **6-3**  
5. Wiring Diagram

## AI: CRUISE CONTROL SYSTEM (OPTION)

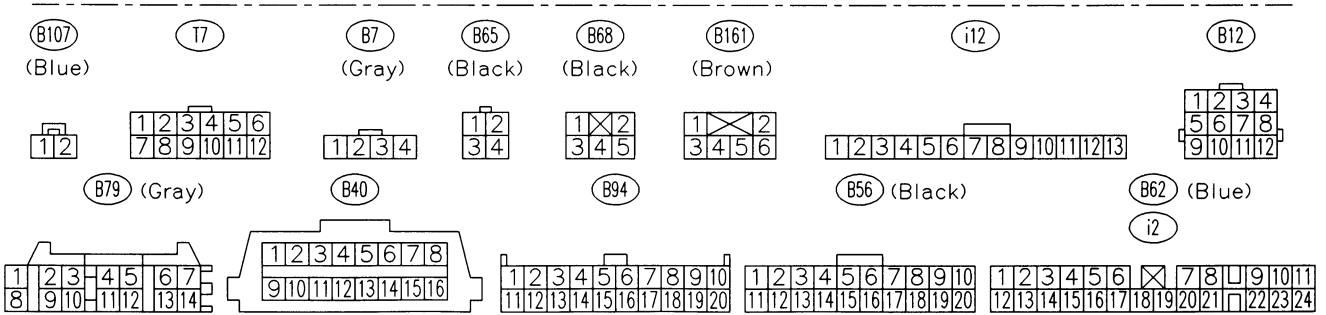
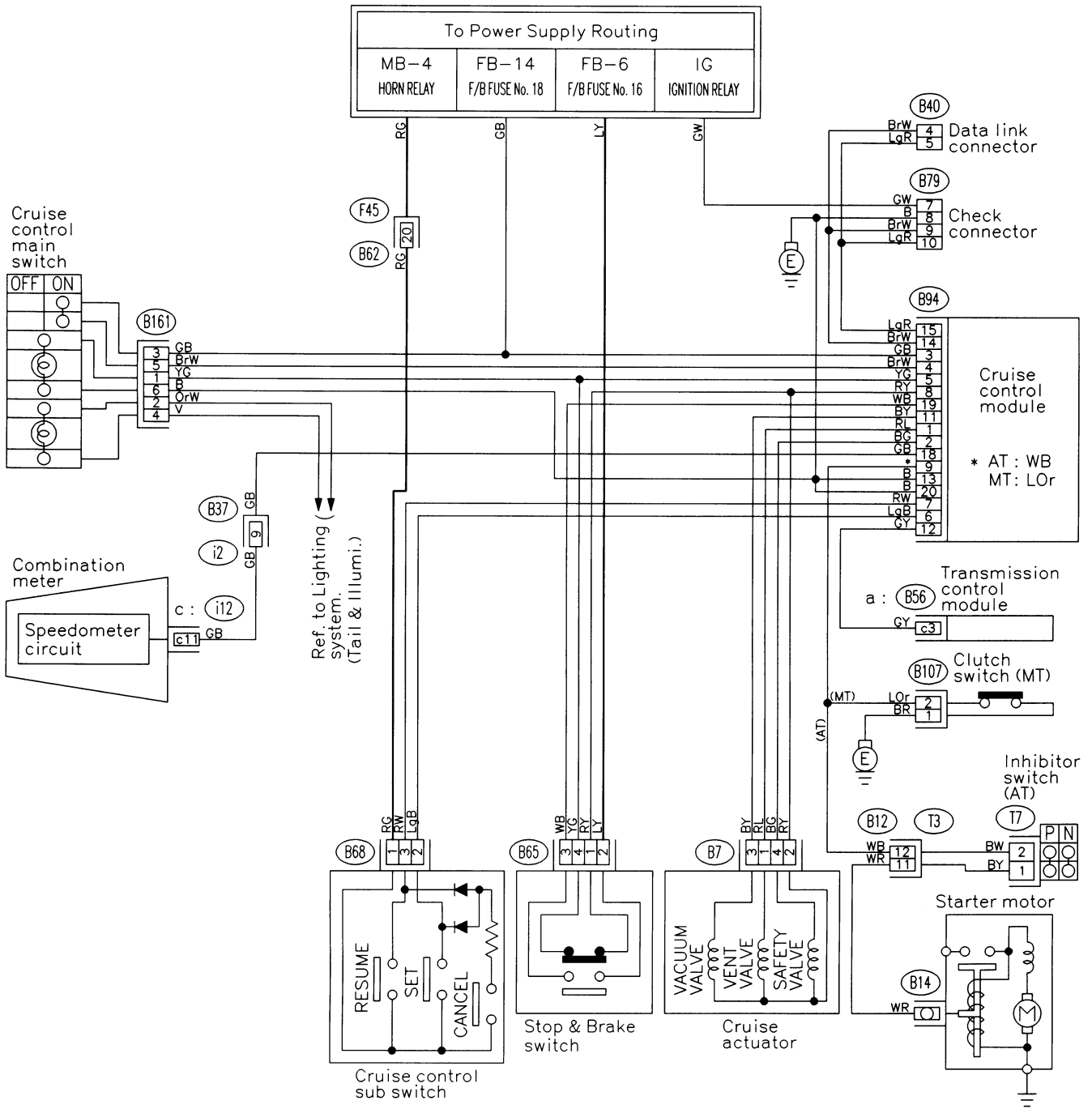

CU71-06

**MEMO:**